

Guidelines for Measuring Procedure (October 2022)

Ski Jumping Suits

Measuring the Athlete

Athlete must be in a relaxed position during the measuring. Athlete must be stripped down to shorts and barefoot. Only “slip-type” of underwear is allowed.

Circumference of the body and legs and arms will be measured in 90 degrees to the axis with the following exceptions:

- A) Arm length: measured in an extended horizontal position of both arms from the torso. Length will be measured on the anterior side from the point between the chest muscle and rib cage (see picture #1) to the wrist bone (marked position at the end of the forearm – (processus styloideus unlae) see picture #2).



Picture 1



Picture 2

- B) body height and crotch measurement

the athlete's body length is measured with laser tool, when the athlete lies on a flat surface (table) with his/her head, shoulder blades, buttocks, calves, and heels touching the surface, legs together

sitting height is measured when the athlete is sitting on a flat surface (table) in an upright position with legs 90 degrees knee angle, feet apart, arms stretched at 90 degrees

the crotch height is defined by deducting the measured sitting height from the measured body height.

Standard measuring elements:

- Body height
- Crotch length (see B, C)
- Arm length (see A)
- Neck size
- Foot length

By an athlete's request a re-measuring may occur. However, only a larger value (height, length) will be considered.

Measuring the Suit

Suit is measured on the outer surface. Be sure that the suit is stretched flat and there are no folds. The suit will be marked and measured at the selected point, the athlete is then marked and measured at the corresponding body position.

- A) Anterior arm length (AL) is measured from the intersection of the seams at the armpit, following the seam to the end of the sleeve. Measured length must be no greater than the length of the arm and no shorter than a maximal tolerance of 4 cm.
- B) Anterior crotch length (SL) is measured from the intersection of the seams at the crotch of the suit (SX) following the anterior seam to the hem of the leg part of the suit. Measured length must be no shorter than the measured crotch length of the athlete.
- C) Crotch: vertically from the ground to the crotch. Athlete must wear the jumping-suit and jumping boots in the same way (attached to the boots) as during the jump / during start control before the jump. During the measuring feet must be 30 cm apart and the legs must be fully extended. Measured crotch length must conform to the crotch length measured on the athlete's body.

Intersection of seams at the crotch (Sx) must be the lowest point of the suit. This intersection must be positioned in the middle of the suit (front-to-back) with the maximum tolerance of 2 cm both ways.

Competition equipment control

Any point on the athlete's body can be measured and compared to the corresponding point on the suit. When the athlete is wearing the suit – the athlete must stretch his arms so, that the elbows are 30 cm from the body, when the measurements are taken. Legs are also straight, feet 30 cm apart. Athlete must stand up in an upright position.

The jumping suit must in all places and parts be tight-fitting the athlete's body.

The measurements of the suit must conform the measurement of the body in an upright position with a tolerance of at least 2 cm in addition and a maximum of 4 cm to the body at any part of the suit. An exception is the part around the boot: the jumping suit can be maximally 10 cm larger (beginning at the knee) than the value which is measured around the jumping and must cover the boot. The suit must be made in such a way as to be able to move up and down along the length of the body. The suit cannot be fixed at any place of the body.

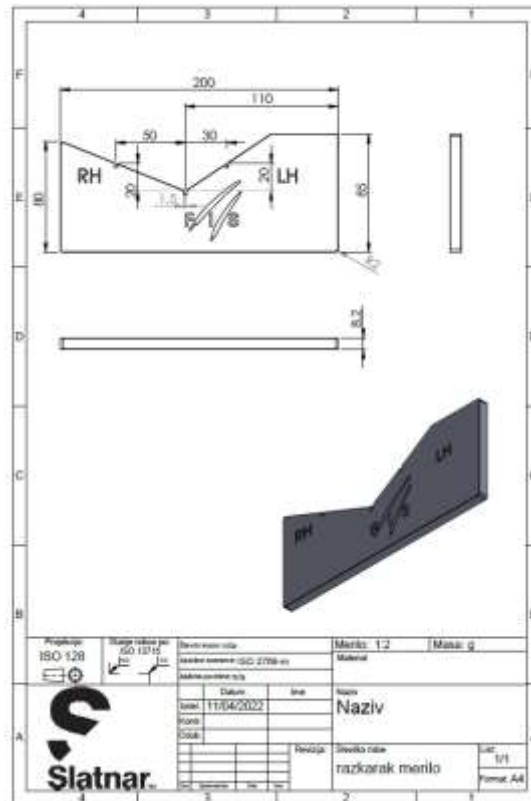

Body weight control

The body weight control takes place without helmet and goggles, gloves, ski jumping boots and wedges.

Zip of the Ski Jumping Suit

The Ski Jumping suit must be closed by means of a zipper that is centered vertically in the middle of the front part of the suit and must reach over the collar bone by minimum 1.5 cm, and maximum 5 cm. The zipper must be completely closed. The minimum distance from the lower end of the zipper and the crotch seam is 10 cm.

Crash helmets, Ski Jumping boots

Measuring the size of the helmet and the boot with a standardized measuring tool and measuring procedure.

Air Permeability

Maximal difference in air permeability of the material measured at any part of a jumping suit is 12 litres, which is the same from the outside in and from the inside out.

Measurement Armpit-Shoulder Part

The measurement of the circumference armpit-shoulder area is measured when the athlete is wearing the suit. The arms are extended at a 45° angle from the body. The athletes are also measured when they are not wearing the suit, with the circumference of the armpit-shoulder area measured with the arms stretched at an angle of 45° from the body.

Underwear

The underwear is consisting of two parts (shirt and pants), made of elastic material:

- A zipper in the middle of the front part of the shirt is allowed
- When using a back protector inside the shirt, a full-length zipper is mandatory

It is not allowed to attach or fix the underwear to any part of the body or the suit (straps, hooks, tapes, or other fixing or helping material, etc.). The arm sleeve must end before the elbow. The leg of the pant must end before the knee. Overlapping of the stockings/socks and the pants is not allowed.

It is not allowed to place one's hair inside the suit or underneath the starting bib. Hair must be left loose outside the suit or placed within the helmet.





Gloves

The seams of the gloves must be inside the gloves.

Transponders and Motion Sensors

Transponders and Motion Sensor delivering live and recorded data that are provided by the official data and scoring provider and approved by FIS. They must be fastened to the front part of the bindings by the competitors in official trainings and competitions for some events. Transponders and Motion Sensors deliver external data from competitors such as speed and positioning. The service will be provided by the official timing and data provider and the generated data must be provided to NSA's and FIS free of charge.

Wedges



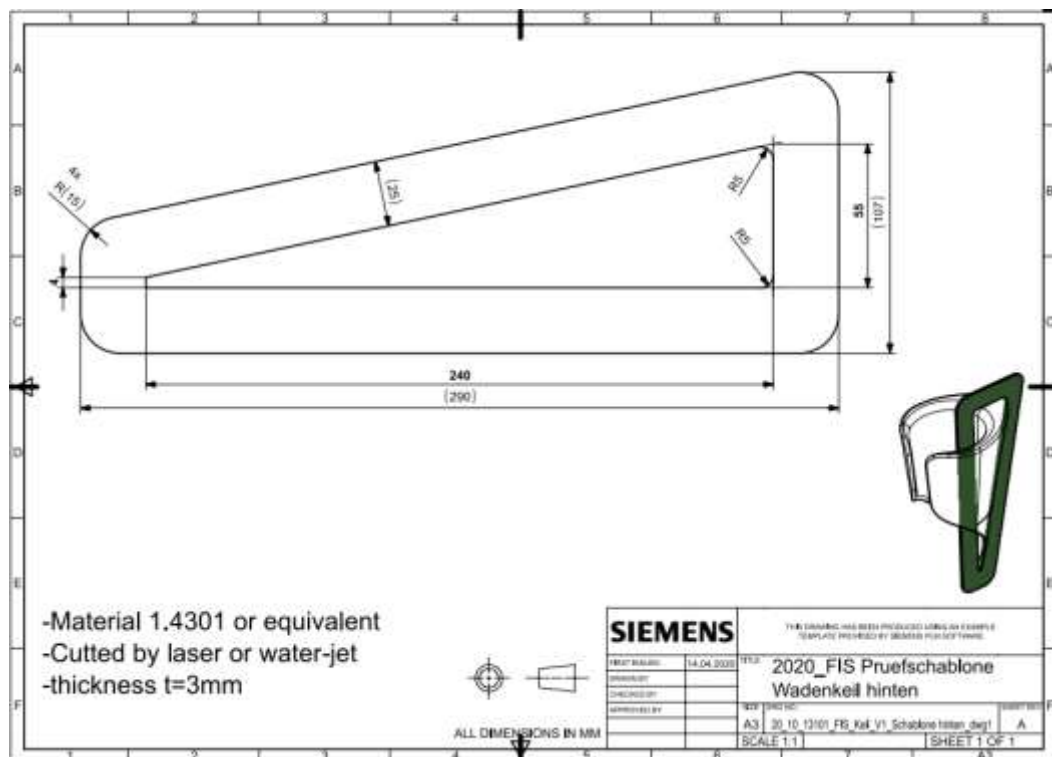
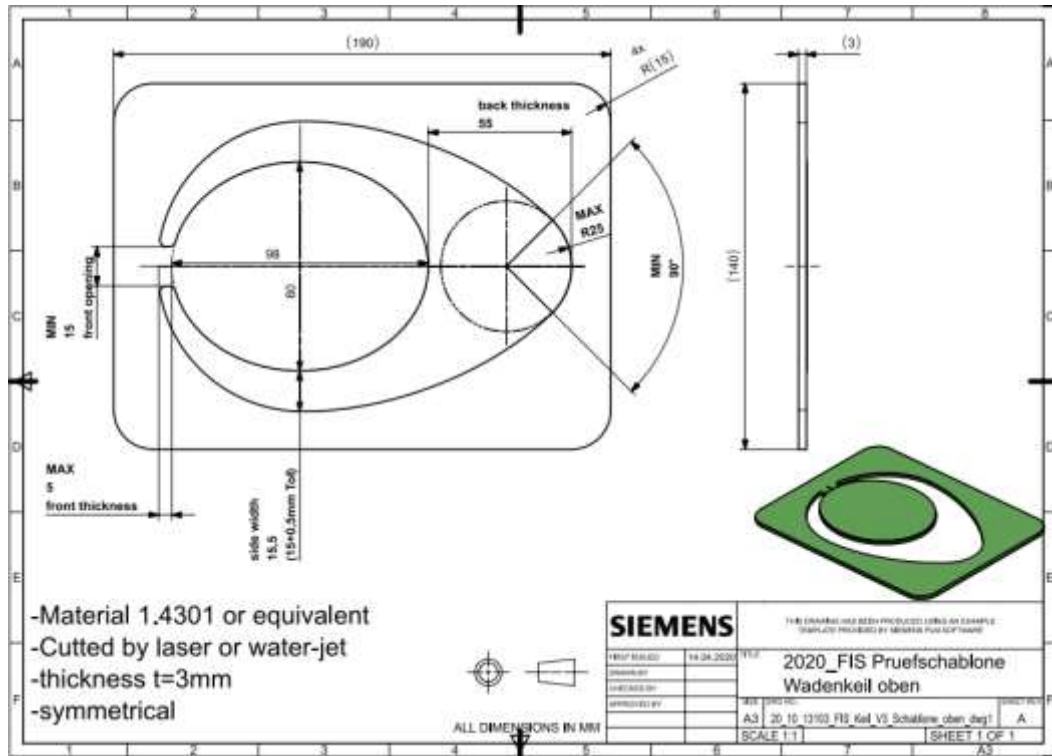

Back protector

Definition

The back protector is an additional item of equipment, which protects the athlete's back against external forces. It has to be worn on the back only.

Specifications of the back protector

The material of the protector consists of visco elastic soft foam with outstanding shock absorption values according to EC EN1621-2:2014 with given form (see Photo 1). The back protector must adapt to the anatomical bend of the athlete's spine and lie flat against the body in upright position.

The maximum size and thickness must conform to the performance level 1 or 2.

The thickness reduces at the edges of the back protector. Designs with the view to improve the aerodynamic efficiency are forbidden. The back protector must be worn in an adequate pocket in the shirt and is removable. The pocket is an integrated part of the shirt.

Sizes of back protectors

S	for body size	120 - 140 cm
M		135 - 155 cm
ML		150 - 170 cm
L		165 - 185 cm
XL		180 - 205 cm

Photo 1 up



Down

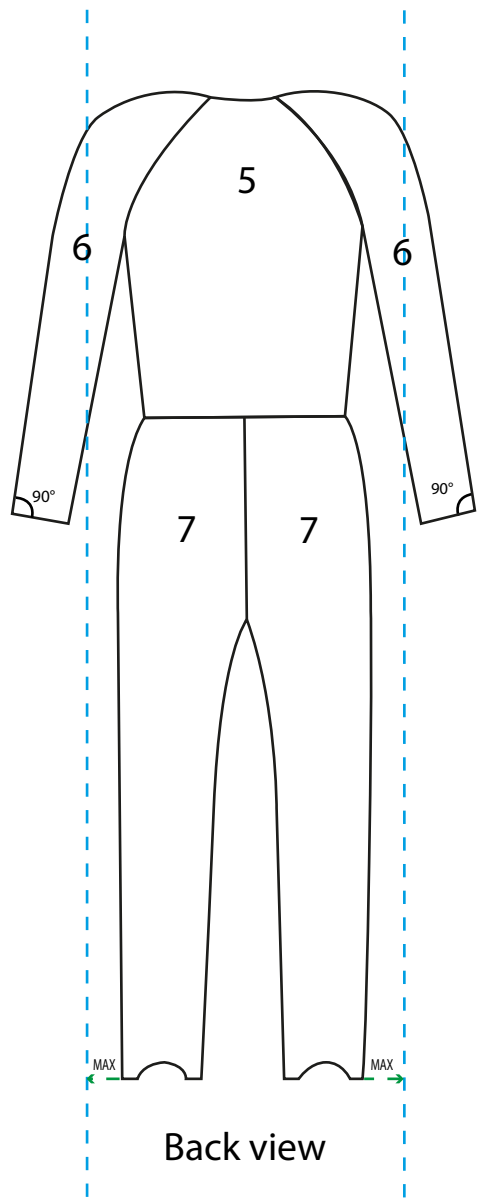

Back view

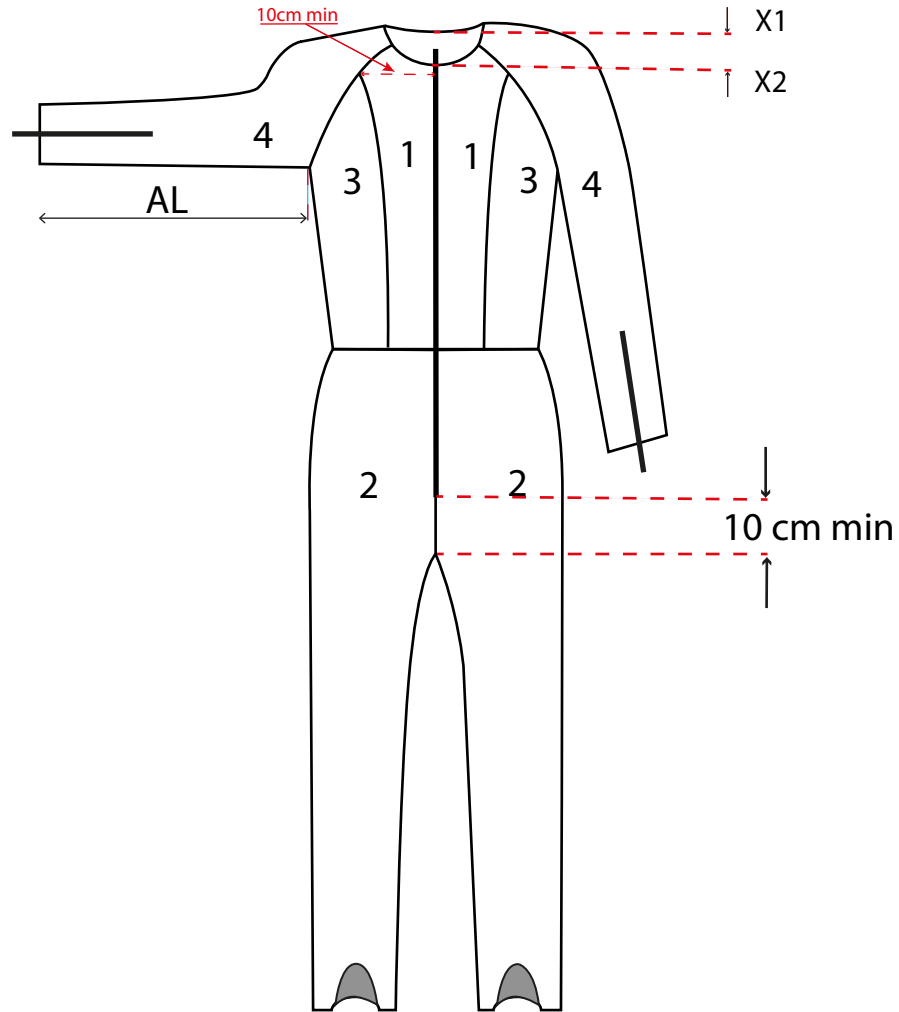

Front view

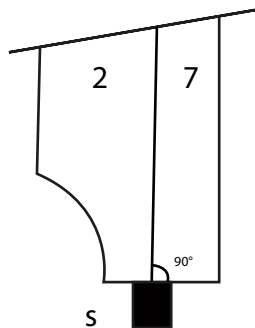
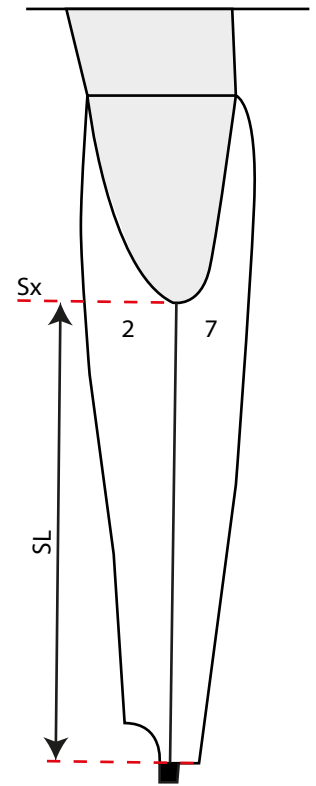

Jumping Suit WOMEN
 Version 1.1
 12. October 2022
 created by: H.Nilgen
 released by: A.Baczowska

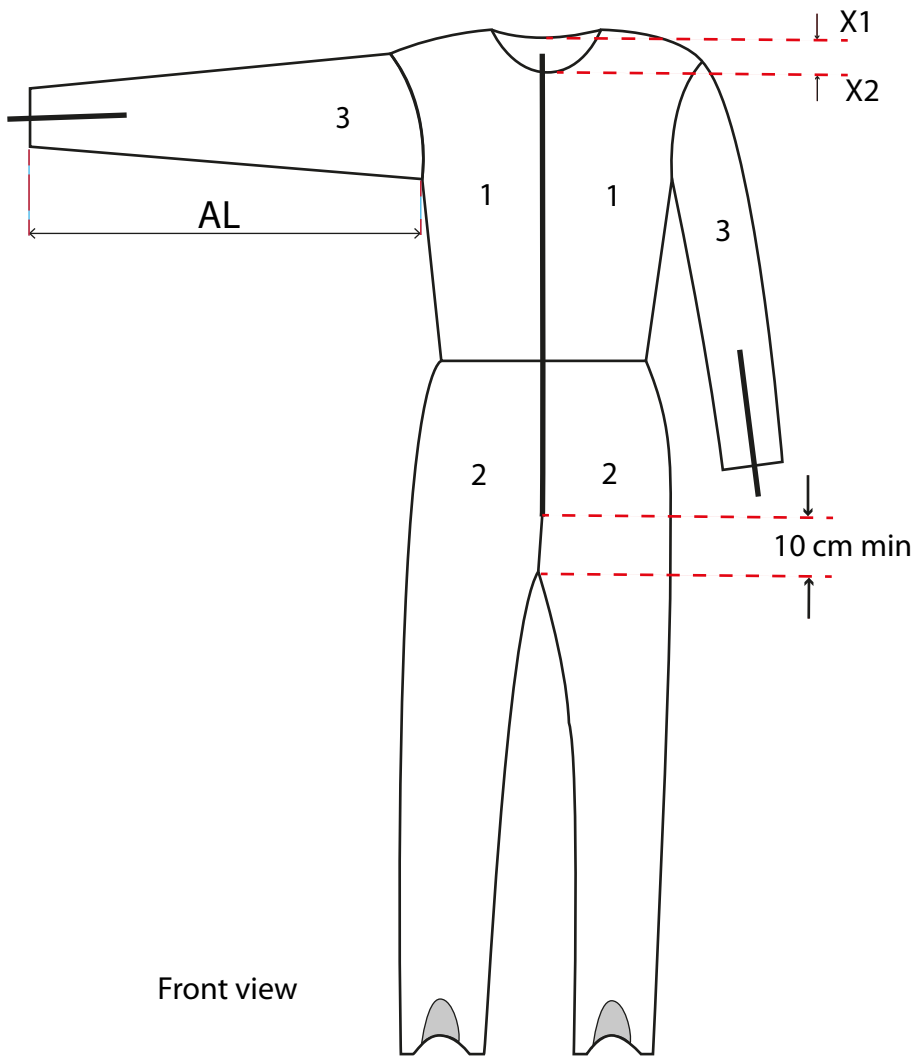

Front view

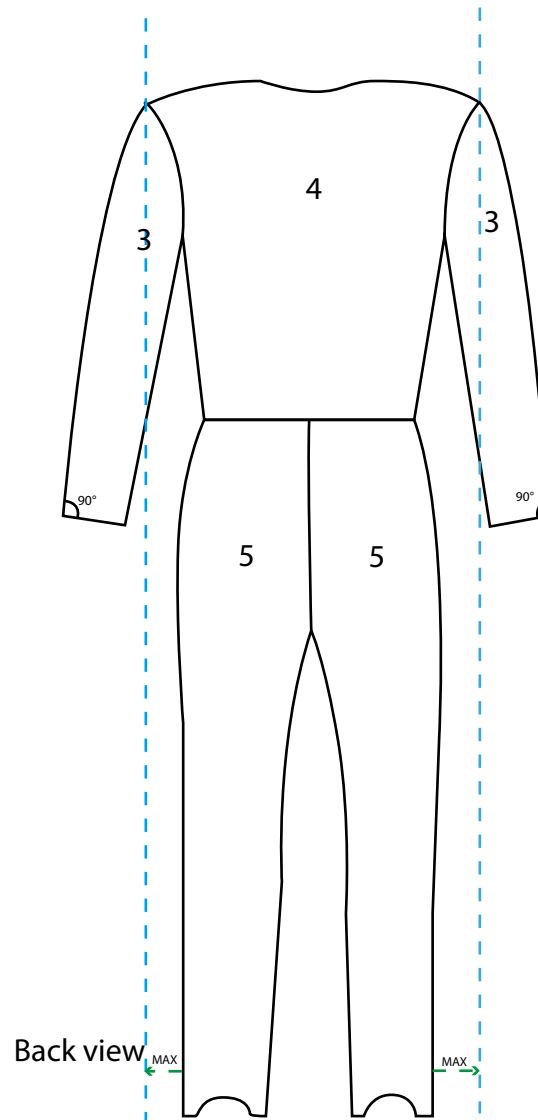

Back view

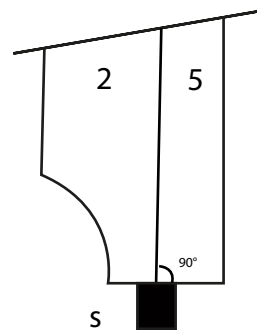
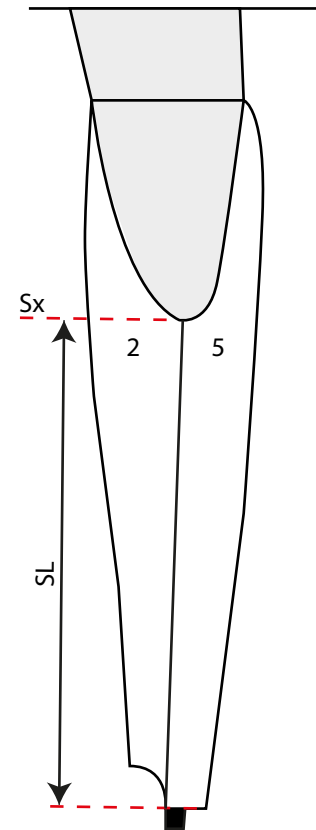

Jumping Suit MEN
 Version 1.1
 12. October 2022
 created by: H.Nilgen
 released by: A.Baczowska