



# THE INTERNATIONAL SKI AND SNOW- BOARD COMPETITION RULES (ICR)

## BOOK VII NORDIC COMBINED

APPROVED BY THE FIS COUNCIL,  
June 2024

## INTERNATIONAL SKI AND SNOWBOARD FEDERATION

Blochstrasse 2; CH- 3653 Oberhofen / Thunersee; Switzerland

Telephone: +41 (33) 244 61 61

Fax: +41 (33) 244 61 71

Website: [www.fis-ski.com](http://www.fis-ski.com)

---

All rights reserved.

© Copyright: International Ski and Snowboard Federation FIS, Oberhofen, Switzerland, 2022.

Printed in Switzerland

Oberhofen, July 2024

## Table of Contents

---

### 1<sup>st</sup> Section

---

<b>200</b>	<b>Joint Regulations for all Competitions.....</b>	<b>3</b>
201	Classification and Types of Competitions.....	3
202	FIS Calendar .....	5
203	Licence to participate in FIS Races (FIS Licence).....	7
204	Qualification of Competitors .....	8
205	Competitors Obligations and Rights .....	9
206	Advertising and Sponsorship.....	10
207	Competition Equipment and Commercial Markings.....	12
208	Exploitation of Electronic Media Rights .....	14
209	Film Rights .....	18
<b>210</b>	<b>Organisation of Competition .....</b>	<b>18</b>
211	The Organisation.....	18
212	Insurance.....	18
213	Programme.....	19
214	Announcements .....	19
215	Entries .....	20
216	Team Captains' Meetings.....	20
217	Draw .....	20
218	Creation and Distribution of Digital Content.....	21
219	Prizes .....	22
<b>220</b>	<b>Team Officials, Coaches, Service Personnel, Suppliers and Firms' .....</b>	<b>22</b>
221	Medical Services, Examinations and Doping.....	23
222	Competition Equipment .....	24
223	Sanctions.....	26
224	Procedural Guidelines .....	27
225	Appeals Commission.....	29
226	Violation of Sanctions.....	31

### 2<sup>nd</sup> Section

---

	<b>Joint Regulations for Nordic Combined Competitions .....</b>	<b>32</b>
<b>500</b>	<b>Organisation .....</b>	<b>32</b>
501	The Competition Committee and Officials .....	32
502	The Jury and Competition Management .....	36
503	FIS Officials for Jury and Competition Management .....	38
504	Judges and Referees .....	43
505	Nomination, Reimbursement and Insurance of Competition Officials.....	44
506	Team Captains' Meeting.....	48
<b>510</b>	<b>The Jumping Hill .....</b>	<b>49</b>
511	Information on the Jumping Hills .....	49

512	Information to the Cross-Country courses .....	51
513	Working conditions at the Competition areas .....	53
514	Measuring Devices .....	54
515	Preparation of the Competition areas .....	59
516	Information for Spectators and Press .....	63
<b>520</b>	<b>Competition and Competitors .....</b>	<b>64</b>
521	Requirements of the Competitors .....	64
522	Entry .....	65
523	Draw .....	66
524	Training before the Competitions .....	67
525	Competition Realisation .....	68
526	Bibs .....	74
527	Calculating and Announcement of Results.....	74
528	Competition Formats .....	77
<b>530</b>	<b>Sanctions and Protests.....</b>	<b>77</b>
531	Sanctions.....	79
532	Protests .....	81
533	Authorization .....	81
534	Right of Appeal.....	82

---

### 3<sup>rd</sup> Section

---

#### Special Regulations for the Competition Formats ..... 83

<b>540</b>	<b>Individual Gundersen Competition.....</b>	<b>83</b>
541	Individual Compact Competition.....	83
542	Individual Mass Start Competition .....	84
543	Team Gundersen Competition .....	85
544	Team-Sprint / Mixed Team-Sprint Competition .....	86
545	Mixed Team Competition.....	86
546	Summer Competitions.....	88
547	Ski Flying Competition.....	88

---

### 4<sup>th</sup> Section

---

#### Tables for Nordic Combined Cross-Country ..... 90

<b>550</b>	<b>The Calculation of the Time Difference .....</b>	<b>90</b>
551	Table Value .....	91

---

## **1<sup>st</sup> Section**

---

### **200 Joint Regulations for all Competitions**

200.1 All events in the FIS Calendar must be held under the applicable FIS Rules<sup>1</sup>.

#### **200.2 Organisation and Conduct**

Rules and instructions for the organisation and conduct of the various competitions are to be found in their respective rules.

#### **200.3 Participation**

Competitions listed in the FIS Calendar are only open to all properly licensed competitors entered by their National Ski Associations in accordance with current quotas.

#### **200.4 Special Regulations**

The FIS Council can authorise a National Ski Association to adopt rules and regulations to organise national or international competitions with different grounds for qualification but only provided that they do not go beyond the limits laid down in the present rules.

#### **200.5 Control**

All competitions listed in the FIS Calendar must be supervised by a Technical Delegate of the FIS.

200.6 Every legal sanction imposed and published in respect of competitors, official or trainer will be recognised by the FIS and the National Ski Associations respectively.

### **201 Classification and Types of Competitions**

#### **201.1 Competitions with Special Rules and/or Limited Participation**

National Ski Associations affiliated with the FIS - or clubs belonging to these National Ski Associations with the approval of their association - may invite neighbouring National Ski Associations or their clubs to their own competitions. But these competitions must not be promulgated or announced as international competitions, and the limitation must be made clear in the announcement.

201.1.1 Competitions with special rules and/or limited participation or including non-members may be held under special competition rules as approved by the FIS Council. Any such rules must be published in the announcement.

#### **201.2 Competitions with Non-Members of the FIS**

The FIS Council can authorise one of its member National Ski Associations to invite a non-member organisation (military etc.) to competitions, or accept invitations from such an organisation.

### **201.3 Classification of Competitions**

201.3.1 Olympic Winter Games, **Paralympic Winter Games**, FIS World Ski Championships and FIS World Junior Ski Championships

201.3.2 FIS World Cups

201.3.3 FIS Continental / Inter-Continental Cups

201.3.4 International FIS Competitions (FIS Races)

201.3.5 Competitions with Special Participation and/or Qualifications

201.3.6 Competitions with Non-Members of the FIS

### **201.4 FIS Disciplines**

A discipline is a branch of a sport and may comprise one or several events. For example Cross-Country Skiing is a FIS Discipline, whereas the Cross-Country Sprint is an Event.

#### *201.4.1 Recognition of Disciplines in the International Ski Federation*

New disciplines, comprising one or several events, widely practised in at least twenty-five countries and on three continents may be included as part of the programme of the International Ski Federation.

#### *201.4.2 Exclusion of Disciplines from the International Ski Federation*

If a discipline is no longer practised in at least twelve National Ski Associations on at least two continents the FIS Congress may decide to exclude the discipline from the programme of the International Ski Federation.

### **201.5 FIS Events**

An event is a competition in a sport or in one of its disciplines. It results in a ranking and gives rise to the award of medals and/or diplomas.

### **201.6 Types of Competitions**

International competitions consist of:

#### *201.6.1 Nordic Events and Para Nordic Events*

Cross-Country, Rollerskiing, Ski Jumping, Ski Flying, Nordic Combined, Team Competitions in Nordic Combined, Nordic Combined with Rollerskiing or In-line, Team Ski Jumping, Ski Jumping on plastic jumping hills, Popular Cross-Country races, Para Cross-Country and Para Biathlon

#### *201.6.2 Alpine and Para Alpine Events*

Downhill, Slalom, Giant Slalom, Super-G, Parallel Competitions, Combined, KO, Team Competitions

#### *201.6.3 Freestyle Ski Events*

Moguls, Dual Moguls, Aerials, Aerials Synchro, Ski Cross, Halfpipe, Slopestyle, Big Air, Rail Team Competitions

- 201.6.4 *Snowboard Events and Para Snowboard Events*  
Slalom, Parallel Slalom, Giant Slalom, Parallel Giant Slalom, Banked Slalom, Halfpipe, Snowboard Cross, Big Air, Slopestyle, Rail, Team Competitions, Banked slalom, Dual Banked slalom
- 201.6.5 *Telemark Events*
- 201.6.6 *Firngleiten*
- 201.6.7 *Speed Skiing Events*  
Speed 1 (S1), Speed 2 (S2), Speed 2 Junior (S2J)
- 201.6.8 *Grass Ski Events*
- 201.6.9 *Combined Events with other Sports*
- 201.6.10 *Youth, Masters, Para Snow Events, etc.*

## **201.7 FIS World Championship Programme**

- 201.7.1 To be included in the programme of the FIS World Championships, events must have a recognised international standing both numerically and geographically, and have been included for at least two seasons in the World Cup before a decision about their admission can be considered.
- 201.7.2 Events are admitted no later than three years before specific FIS World Championships.
- 201.7.3 A single event cannot simultaneously give rise to both an individual and a team ranking.
- 201.7.4 Medals may only be awarded at the FIS World Championships and FIS Junior World Championships in all disciplines (Alpine, Nordic, Snowboard, Freestyle, Grass Skiing, Rollerski, Telemark, Speed Skiing) when there are a minimum of 8 nations participating in team competitions and 8 nations represented in an individual event.
- 201.7.5 The article 201.7.4 shall not be applied to the Para Snow Sports events (all levels) until the competition season 2026/2027 when specific Para numbers will be defined

## **202 FIS Calendar**

### **202.1 Candidature and Announcement**

- 202.1.1 Each National Ski Association is entitled to present its candidature for the organising of the FIS World Ski Championships in accordance with the published "Rules for the Organisation of World Championships"
- 202.1.2 For all other competitions, the registrations for inclusion in the International Ski Calendar have to be made to FIS by the National Ski Association according to the Rules for the FIS Calendar Conference published by the FIS.

- 202.1.2.1 The applications of the National Ski Associations (NSA) are entered by using the FIS Calendar program in the member section of the FIS website: [www.fis-ski.com](http://www.fis-ski.com) by 31<sup>st</sup> August (31<sup>st</sup> May for the Southern Hemisphere).
- 202.1.2.2 *Allocation of competitions*  
Allocation of the competitions to the National Ski Associations is made through the electronic communication process between FIS and the National Ski Associations. In the case of FIS World Cup competitions, the calendars are subject to the approval of the Council, on proposal of the respective Technical Committee.
- 202.1.2.3 *Homologations*  
Competitions that appear in the FIS Calendar may only take place on competition courses or jumping hills homologated by the FIS.  
The homologation certificate number must be indicated when applying for the inclusion of the competition in the FIS Calendar. In a number of Snowboard, Freestyle Ski, Freeski events the course or facility is built up for each competition that therefore do not have a permanent homologation. The course or facility approval process is therefore defined in the respective rules
- 202.1.2.4 *Publication of the FIS Calendar*  
The FIS calendar is published by FIS on the FIS website [www.fis-ski.com](http://www.fis-ski.com). It will be updated to reflect cancellations, postponements and other changes continuously by FIS.
- 202.1.2.5 *Postponements*  
In case of the postponement of a competition listed in the FIS Calendar, the FIS has to be informed immediately and a new invitation must be sent to the National Ski Associations, otherwise the competition cannot be considered for FIS Points.
- 202.1.2.6 *Calendar Fees*  
In addition to the annual subscription, a calendar fee is set by the FIS Congress and is due for each year and for each event listed in the FIS Calendar. For additional events, a 50% surcharge will be made in addition to the regular calendar fee for applications submitted 30 days before the date of the competition. The calendar fee for a competition that has to be rescheduled remains the responsibility for payment in full of the original organising National Ski Association.  
  
At the beginning of the season, each NSA will receive an invoice for 70 % of its total invoice from the previous season. This amount will be debited from its FIS account. At the end of the season each NSA will receive a detailed invoice for all registered competitions during the season. The balance will be subsequently be debited or credited to the NSA account at FIS.
- 202.1.3 *Appointment of Race Organiser*  
In the event that the National Ski Association appoints a race organiser, such as an affiliated ski club, it shall do so using the form "Registration Form National Ski Association and Organiser" or by means of a similar written agreement. An application by a National Ski Association for inclusion of an



event on the International Ski Calendar shall mean that the necessary agreement to organise the event has been established.

## **202.2 Organisation of Races in other Countries**

Competitions which are organised by other National Ski Associations may only be included in the FIS Calendar when the National Ski Association of the country concerned where the competitions will be organised gives its approval.

## **203 Licence to participate in FIS Races (FIS Licence)**

A licence to participate in FIS races is issued by a National Ski Association to competitors who fulfil the criteria for participation through registering the competitor with FIS in the respective discipline(s).

203.1 The FIS licence year begins on July 1<sup>st</sup> and finishes on June 30<sup>th</sup> of the following year.

203.2 To be eligible for participation in FIS events, competitors must have a licence issued by their National Ski Association. Such a licence shall be valid in the Northern and Southern hemispheres for the licence year only. The validity of a licence can be limited to participation in one specific country or in one or more specific events.

203.2.1 The National Ski Association must guarantee that all competitors registered with a FIS License to participate in FIS races accept the Rules of the International Ski Federation, in particular the provision which foresees the exclusive competence of the Court of Arbitration for Sport as the court of appeal in doping cases.

203.3 A National Ski Association may only issue a FIS licence to participate in FIS races when the competitors have proven their nationality and therefore eligibility by submitting a copy of their passport and signed the Athletes Declaration in the form approved by the FIS Council and returned it to their National Ski Association. All forms from under-age applicants must be counter signed by their legal guardians. Both the copy of the passport and signed Athletes Declaration must be made available to FIS on request.

203.4 During the FIS licence year, competitors may only participate in International FIS competitions with a FIS licence to participate in FIS races issued by one National Ski Association.

### **203.5 Application for a change of FIS Licence Registration**

All applications to change licence registration from one member National Ski Association to another are subject to consideration by the FIS Council at its Meetings in the spring (applications may only be submitted by 1<sup>st</sup> May each year). In principle an application to change licence registration will not be granted unless the competitors demonstrate their personal association with the new nation.

Prior to submitting an application to change licence registration competitors must possess the citizenship and passport of the country for which they wish to compete. In addition, competitors must have had their principal legal and effective place of residence in the new country for a minimum of two (2) years immediately prior to the date of the request to change registration to the new

country/National Ski Association. An exception to the two year residency rule may be waived if the competitor was born in the territory of the new country, or whose mother or father is a national of the new country. Applications will not be accepted if a parent has obtained a passport for the new country, but is not resident, and/or there is no family ancestry.

Furthermore, competitors are required to submit a detailed explanation with the application about their personal circumstances and the reason for requesting a change of licence registration.

203.5.1 If competitors have already participated in FIS calendar events for a National Ski Association, they must have the written agreement to be released from the former National Ski Association in addition to the citizenship, passport and residency requirements in art. 203.5 before the new National Ski Association may submit a request to FIS for a change of registration.

If such a written agreement is not given, the competitor may not participate in any FIS calendar events for a period of twelve months from the end of the last season in which they competed for their present National Ski Association, nor may they be issued with a licence to participate in FIS races by the new National Ski Association.

These rules are also valid when a competitor has more than one nationality and would like to change National Ski Association licence registration.

203.5.2 The FIS Council reserves the right in its absolute discretion, to grant or to decline to grant, a change of licence notwithstanding the fulfilment of the aforementioned conditions where it deems it is contrary to the spirit of the rule and in the best interests of the International Ski Federation to do so (e.g. to decline to grant a change of licence if a member National Ski Association tries to “import” a competitor).

203.5.3 In the event that a competitor does not fulfil all the criteria required to apply for a change of National Ski Association licence registration, the onus shall be on the competitor to demonstrate in writing to the satisfaction of the FIS Council that exceptional circumstances exist and it is in the best interests of the International Ski Federation to grant the change.

203.5.4 Competitors will retain their FIS points if they change their National Ski Association under the condition that the former National Ski Association granted the release of the competitor.

203.5.5 In the event that any of the documents for an application to change licence registration submitted by the National Ski Association (letter of release from the former National Ski Association, passport, residency papers) are found to be false, the FIS Council will sanction the competitor and the new National Ski Association.

## **204 Qualification of Competitors**

204.1 A National Ski Association shall not support or recognise within its structure, nor shall it issue a licence to participate in FIS or national races to competitors who:

204.1.1 have conducted themselves in an improper or unsportsmanlike manner or have not respected the FIS medical code or anti-doping rules,

- 204.1.2 accept or have accepted, directly or indirectly, any money-payments for the participation at competitions,
- 204.1.3 accept or have accepted a prize of a higher value than fixed by article 219,
- 204.1.4 permit or have permitted their names, titles or individual pictures to be used for advertising, except when the National Ski Association concerned, or its pool for this purpose, is party to the contract for sponsorship, equipment or advertisements.
- 204.1.5 knowingly compete or have competed against any skier not eligible according to the FIS Rules, except if:
  - 204.1.5.1 the competition is approved by the FIS Council, is directly controlled by the FIS or by a National Ski Association, and the competition is announced "open",
- 204.1.6 have not signed the Athletes Declaration,
- 204.1.7 are under suspension.
- 204.2 With the issuance of a licence to participate in FIS competitions and entry the National Ski Association confirms, that valid and sufficient accident insurance for training and competition is in place for the competitors and assumes full responsibility.

## **205 Competitors Obligations and Rights**

Competitors whatever their age, gender, race, religion or belief, sexual orientation, ability or disability have the right to participate in snow sports in a secure environment and protected from abuse.

FIS encourages all member nations to develop policies to safeguard and promote the welfare of children and young persons.

- 205.1 The competitors are obliged to make themselves familiar with the appropriate FIS Rules and must comply with the additional instructions of the Jury. Competitors must also follow the FIS rules regulations.
- 205.2 Competitors are not permitted to use doping. (see FIS Anti-Doping Rules and Procedural Guidelines).
- 205.3 As stated in the Athletes Declaration, competitors have the right to inform the Jury of safety concerns they may have regarding the training and competition courses. More details are given in the corresponding discipline rules.
- 205.4 Competitors who do not attend the prize-giving ceremonies without excuse lose their claim to any prize including prize money.  
In exceptional circumstances, competitors may be represented by another member of their team, but this person has no right to take their place on the podium.
- 205.5 Competitors must behave in a correct and sportsmanlike manner towards members of the Organising Committee, volunteers, officials and the public.

## **205.6 Support for the Competitors**

205.6.1 *Competitors is registered with FIS by their National Ski Association to participate in FIS races may accept:*

205.6.2 full compensation for travel cost to training and competition,

205.6.3 full reimbursement for accommodation during training and competitions,

205.6.4 pocket money,

205.6.5 compensation for loss of income according to decisions of their National Ski Association,

205.6.6 social security including insurance for training and competition,

205.6.7 scholarships.

205.7 A National Ski Association may reserve funds to secure their competitors' education and future career after retiring from active competitive skiing. The competitors have no claim to these funds which shall be dispensed only according to the judgement of their National Ski Association.

## **205.8 Gambling on Competitions**

Competitors, trainers, team officials and technical officials are prohibited from betting on the outcome of competitions in which they are involved.

Reference is made to the FIS Rules on the Prevention of the Manipulation of Competitions.

## **206 Advertising and Sponsorship**

In the context of this rule advertising is considered as the presentation, of signage or other visibility at the venue informing the public of the name of a product or service to achieve awareness of a company or an organisation and its brand name, activities, products or service. On the other hand Sponsorship provides a company with the opportunity to have a direct association with the competition or series of events.

### **206.1 Olympic Winter Games, Paralympic Winter Games and FIS World Championships**

All Advertising and Sponsorship rights to the Olympic Winter Games, Paralympic Winter Games and FIS World Championships belong to the IOC, IPC and to the FIS respectively and are subject to separate contractual arrangements.

### **206.2 FIS Events**

For all FIS Events the FIS Advertising Rules define the advertising opportunities in the competition area and are subject to the approval of the FIS Council. For the FIS World Cup Events the FIS Advertising Rules form an integral part of the FIS Organisers Agreement with the National Ski Associations and Organisers.

### **206.3 Member National Ski Associations**

Each FIS affiliated National Ski Association that organises events in its country which are included in the FIS calendars, ~~has the authority as the~~ retains ownership of the event advertising rights ~~to enter into contracts for their sale provided they enter into a Media Rights Centralisation Agreement (MRCA) for long as that MRCA remains in full force and effect.~~ In the case of FIS World Cup competitions these rights shall be defined in the Organiser Agreement upon approval of the FIS Council and considering the National Ski Associations responsibilities.

In cases where a National Ski Association organises events outside its own country these FIS Advertising rules also apply.

If an NSA does not enter into an MRCA, FIS shall exclusively be entitled to enter into any agreement concerning the advertising rights of World Cup events awarded to that NSA.

### **206.4 Title and Presenting Sponsorship Rights**

In the case of FIS series approved by the FIS Council, FIS markets the rights of the title/presenting sponsor (alternative naming possible) package. For the FIS World Cup series these are marketed to appropriate sponsors that promote the image and values of the discipline concerned. The revenue generated from the sale of the title/presenting sponsor rights is invested by FIS to provide a professional organisation.

### **206.5 Use of Markings and supports**

All Advertising and commercial markings and supports used shall comply with the technical specifications set forth in the applicable FIS Advertising Rules.

### **206.6 Advertising Packages**

Location, number, size and form of the advertising are specified in the FIS Advertising Rules for each discipline. Detailed information including graphical illustrations is laid out in the discipline-specific Marketing Guides which are published on the FIS Website. The Marketing Guides are reviewed and updated as necessary by the Committee for Advertising Matters and approved by the FIS Council prior to their publication.

### **206.7 Sponsorships by commercial betting companies**

206.7.1 FIS will not allocate Title / Presenting Sponsor rights to commercial betting companies.

206.7.2 Sponsorships of events by commercial betting companies is permitted subject to 206.7.4 below.

206.7.3 Advertising of betting companies is allowed on bibs after approval by FIS, valid for 3 years.

206.7.4 Approval by FIS will be given under the condition that the betting company/ies actively work/s against sport competition manipulation.

206.8 A National Ski Association or its pool may enter into contracts with a commercial firm or organisation for financial sponsorship and or the supply of goods or equipment if the specific company or organisation is acknowledged as an

Official Supplier or Sponsor by the National Ski Association. Advertising using photographs, likeness or names of FIS competitors with any sportsman not eligible according to either the FIS eligibility rules or the eligibility rules of the IOC, is forbidden.

Advertising with or on competitors with tobacco or alcohol products or drugs (narcotics) is forbidden.

206.9 All compensation under such contracts must be made to the National Ski Association or its ski pool which shall receive the compensation subject to the regulations of each National Ski Association. Competitors may not directly receive any part of such compensation except as stated in art. 205.6. The FIS may at any time call for a copy of the contract.

206.10 Equipment goods supplied to and used by the national team must, with reference to markings and trademarks, conform with the specifications stated in art. 207.

## **207 Competition Equipment and Commercial Markings**

### **207.1 Competition Equipment at FIS Events**

Only the competition equipment, according to the FIS rules on advertising, provided by the National Ski Association, complete with the commercial markings approved by the National Ski Association, may be worn in FIS World Cup and FIS World Ski Championships competitions. Obscene names and/or symbols on clothing and equipment are forbidden.

207.1.1 At FIS World Ski Championships, FIS World Cup and all events on the FIS Calendar, a competitor is not allowed to take equipment (skis,/board, poles, ski boots, helmet, glasses) to the official ceremonies involving anthems and/or flag raising. Holding/carrying equipment on the victory podium after conclusion of the whole ceremony (handing over trophies and medals, national anthems) for press photos, pictures, etc. is however permitted.

#### *207.1.2 Winners presentation / Equipment on the podium*

At FIS World Ski Championships and all events of the FIS Calendar, a competitor is allowed to take the following equipment on the podium:

- Skis / Snowboards
- Footwear: The athletes may wear their boots on their feet, but are not allowed to wear them anywhere else (such as around their neck). Other shoes cannot be taken on the podium during presentation except if they are worn on the feet.
- Poles: not on/around skis, normally in the other hand
- Goggles: either worn or around the neck
- Helmet: if worn only on the head and not on another piece of equipment, e.g. skis or poles
- Ski straps: maximum of two with name of the producer of skis; eventually one can be used for a wax company
- Nordic Combined and Cross-Country Ski Poles Clips. A clip can be used to hold the two poles together. The clip can be the width of the two poles, though not wider than 4 cm. The length (height) can be 10 cm. The long side of the clip is to be parallel to the poles. The commercial marking of the pole manufacturer can cover the entire surface of the clip.

- All other accessories are prohibited: waist bags with belt, phones on neckbands, bottles, rucksack/backpack, etc.

207.1.3 An unofficial presentation (flower ceremony) of the winner, and the winners ceremony immediately after the event in the event area with the national anthem even before the protest time has expired, is allowed at the organiser's own risk. Visible wearing of the starting bibs is mandatory.

207.1.4 Visible wearing of the starting bib of the event or other outerwear of the NSA is mandatory in the restricted corridor (including the leader board and TV interview locations).

## **207.2 Commercial Markings**

Specifications about the size, the form and the number of commercial markings on equipment and clothing as well as the by-laws for commercial markings and for advertising are to be reviewed by the Committee for Advertising Matters and approved by the FIS Council each spring for the following competition season and published by the FIS.

207.2.1 The rules governing commercial markings and advertising on equipment and clothing as well as the relevant by-laws published in the Specifications for Competition ~~Equipment/Commercial~~ Markings on Equipment, must be followed.

207.2.2 Any competitor who breaches the advertising rules is subject to sanction, as provided for in art. 223.1.1. An offence for which a sanction may apply and a penalty be imposed is defined as conduct that is in violation or non – observance of competition rules.

207.2.3 If a National Ski Association fails to enforce these rules with on their own competitor(s) or for any reason prefers to refer the case to the FIS, the FIS may take immediate steps to suspend a competitor's licence. The competitors concerned and/or their National Ski Association have the right to make an appeal before a final decision is taken.

207.2.4 If an advertiser uses the name, title or individual picture of competitors in connection with any advertisement, recommendation or sale of goods without the approval or knowledge of the competitor, the competitor may give a "power of attorney" to their National Ski Association or to the FIS to enable them, if necessary, to take legal action against the company in question. If the competitor concerned fails to do so, the FIS shall judge the situation as if the competitor had given permission to the company.

207.2.5 The FIS Council shall be informed of infractions or breaches of these rules that have taken place with regard to the qualification of competitors, sponsorship and advertising and support for the competitors, and shall review what measures to take to deal with cases.

## **208 Exploitation of Electronic Media Rights**

### **208.1 General Principles**

#### *208.1.1 Olympic Winter Games, Paralympic Winter Games and FIS World Championships*

All Media rights to the Olympic Winter Games, Paralympic Winter Games and FIS World Championships belong to the IOC and to the FIS respectively, and are subject to separate contractual arrangements.

#### *208.1.2 Rights owned by the member National Ski Associations*

Each FIS affiliated National Ski Association that organises events in its country which are included in the annual FIS calendars, ~~has the authority as the~~ retains ownership of the electronic media rights ~~to enter into contracts for the sale of the electronic media rights~~ provided they enter into a Media Rights Centralisation Agreement (MRCA) for so long as that MRCA remains in full force and effect. In cases where a National Ski Association organises events outside its own country, these rules also apply, subject to bi-lateral agreement with the National Ski Association of the country where the event takes place.

If an NSA does not enter onto an MRCA, FIS shall exclusively be entitled to enter into any agreement concerning the electronic media rights of World Cup events awarded to that NSA.

#### *208.1.3 Promotion*

Contracts shall be prepared in consultation with the FIS with the intention of giving the widest promotion and exposure to the sports of skiing and snowboarding and considering the best interests of the National Ski Associations.

#### *208.1.4 Access to events*

For all competitions, admission of personnel and their equipment to the media areas will be limited to those having the necessary accreditation and access passes. Priority access will be given to rights holders and the system of accreditation and access control must avoid possible abuse by non-rights holders.

#### *208.1.5 Control by the FIS Council*

The FIS Council exercises control over the adherence to the principles of this Rule by National Ski Associations and all organisers. Should a contract or individual clauses thereof, create a major conflict of interest for the FIS, a member National Ski Association or its organiser, then this will be evaluated by the FIS Council. Full information will be provided so that the appropriate solution can be found.

### **208.2 Definitions**

In the context of this rule the following definitions will apply:

“Electronic Media Rights” means the rights for Television, Radio, Internet and Mobile devices.

“Television rights” means the distribution of television images, both analogue and digital, comprising video and sound, by means of terrestrial transmitters,



satellite, cable, fibre or wire for public and private viewing on television screens. Pay-per-view, subscription, interactive TV, video on demand services, IPTV or similar technologies, are also included in this definition.

“Radio rights” means the distribution and reception of radio programmes, both analogue and digital, over the air, by wire or via cable to devices, both fixed and portable.

“Internet” means access to images and sound through interconnected computer networks.

“Mobile and portable devices” means the provision of images and sound through a telephone operator and receivable on mobile telephone or other non fixed devices, such as Personal Digital Assistants.

## **208.3 Television**

### *208.3.1 Standard of production and promotion of competitions*

In the agreements concerning production with a TV organisation or agency acting as host broadcaster, the quality of TV transmissions for ski and snowboard events published in the FIS Calendar – especially for FIS World Cup competitions – must be considered. Of particular importance, while taking into consideration applicable national laws and rules affecting broadcasting, are:

- a) Top quality and optimal production of a TV signal (for live or deferred transmission depending on the event) in which sport is the centrepiece;
- b) Adequate consideration and appearance of venue advertising and event sponsors;
- c) A standard of production in conformity with the FIS TV Production Guidelines and appropriate to current market conditions for the discipline and to the level of the FIS competition series. This means live coverage of the entire event including the winner presentation for live transmission (unless circumstances determine that a live production is not provided). This coverage shall be produced in a neutral way, shall not concentrate on any athlete or nation and shall show all competitors
- d) The live international signal of the host broadcaster must include appropriate graphics in English, particularly the official FIS logo, timing and data information and results, and international sound.
- e) Where it is appropriate to the individual TV market, there should be live TV transmission in the country where the event takes place and in other countries with a high interest.

### *208.3.2 Production and Technical costs*

Except when otherwise agreed between the National Ski Association and the agency/company managing the rights, the cost of producing the television signal for the exploitation of the different rights will be borne by the broadcaster having acquired the rights in the country where the competition takes place or a production company mandated to produce the signal by the company owning the rights. In certain cases, the organiser or the National Ski Association may assume these costs.

For each of the different rights granted under this rule the technical expenses that are to be paid for by those organisations that have acquired the rights and which

are seeking to access the television signal (original picture and sound without commentary), have to be agreed between the producing company or the agency/company managing the rights, as applicable. This also applies to any other production costs that may be requested.

### 208.3.3

#### *Short extracts*

Short extracts granting news access for non-rights holders are to be provided to television companies according to the following rules. It is noted that in a number of countries national legislation governs the showing of short extracts in news programmes.

These extracts may only be used in regularly scheduled news programmes and cannot be kept for archive purposes

- a) In those countries where legislation exists regarding news access to sporting events then this legislation will always hold precedence for reporting on FIS events.
- b) In those countries where no legislation exists regarding news access by competing networks and provided that agreements between the company managing the rights and the primary rights holder take precedence then short extracts of a maximum of 90 seconds news access will be granted to competing networks by the agency/company managing the rights for transmission four hours after the rights holding network has shown the competition. The use of this material will cease 48 hours after the end of the competition. If the rights holding network delays its transmissions by more than 72 hours from the end of the competition, then competing networks can show extracts of a maximum of 45 seconds commencing 48 hours after and ending 72 hours after the event itself. Any request to exploit short extracts shall be addressed to the agency/company managing the rights which shall grant to the broadcasters access to the short extracts subject to agreement regarding the technical costs incurred to receive the material.
- c) In those countries where no transmission rights have been purchased by a television company, all television organisations will be able to transmit short extracts of 45 seconds as soon as the material is available, subject to agreement with the agency/company managing the rights regarding the technical costs to be incurred to receive the material. Permission for the use of this material will expire after 48 hours.
- d) Short extracts will be produced by the host broadcaster or the agency/company managing the rights and distributed by that agency/company, taking into consideration 208.3.2 above.

### 208.4

#### **Radio**

The promotion of FIS events through radio programmes will be encouraged by making available accreditation to the principle radio station(s) in each interested country. Access to the venue will be granted solely to those radio organisations that have obtained the necessary contractual authorisation from the rights holder, and will be only for the production of radio (audio) programmes. If accepted by national practice and the authorisation is granted, these programmes can also be distributed on the internet site of the radio station.

## **208.5**

### **Internet**

Unless the contract for the sale of the Electronic Media Rights on FIS events states otherwise, each television rights holder that also acquires the internet rights, will ensure that video streams from its website other than short extracts are geoblocked against access from outside its own territory. Regularly scheduled news bulletins containing material of FIS events may be streamed on the rights holding broadcaster's website, provided no changes are made to the bulletin as transmitted in the original programme.

Video and audio material produced in public areas where accreditation, tickets or other permissions are not required to gain access must not contain race footage. It is recognised that new technology provides members of the public with the possibility to produce unauthorised video recordings that may be posted on websites. Appropriate information advising that the unauthorised production and use of video material is prohibited and that legal proceedings could be taken, will be shown at all entrances and printed on entrance tickets. All National Ski Associations and the rights holders/agencies will give permission for short extracts to be placed on the FIS website for non-commercial use subject to the following conditions:

- a) When short extracts have not been acquired for Internet distribution the maximum duration of the news material from FIS competitions will be 30 seconds per discipline/per session and will be accessible on the FIS website until 48 hours after the end of the competition. The financial conditions relating to the provision of this material will be agreed between the FIS and the rights owner.
- b) The material will be provided by the rights owner or host broadcaster as soon as possible, but at the latest six hours after the end of the competition.

## **208.6**

### **Mobile and portable devices**

In the cases where the rights for distribution by mobile and portable devices have been awarded, the rights purchaser/operator will be free to produce from the television signal the content it considers best meets the needs of its customers. Any live streaming of television programmes on a national basis using these devices shall not be altered from that available through other distribution channels.

In countries where no mobile distribution rights have been sold, short extracts or clips of a maximum duration of 20 seconds will be offered to operators when the material has been produced and for a period of 48 hours on the condition that the operators pay all related technical costs to the agency/company managing the rights.

## **208.7**

### **Future developments**

The principles contained in this Rule 208 shall be the basis for the exploitation of Electronic Media Rights to FIS events in the future. The FIS Council, on the recommendation of the National Ski Associations, the relevant commissions and experts, will establish the conditions considered appropriate to each new development.

- 209 Film Rights**  
All agreements regarding film productions of FIS competitions will be between the film producer and the National Ski Association or the company managing the related rights. All contractual arrangements regarding the exploitation of other media rights will be respected.
- 210 Organisation of Competition**
- 211 The Organisation**
- 211.1 The Organiser**
- 211.1.1 The Organiser of a FIS competition is the person or group of persons who make the necessary preparations and directly carry out the running of the competition in the resort.
- 211.1.2 If the National Ski Association itself is not the competition organiser, it may appoint an affiliated club to be the organiser.
- 211.1.3 The organiser must ensure that accredited persons accept the regulations regarding the competition rules and Jury decisions, and in World Cup races the organiser is obliged to obtain the signature of all persons who do not have a valid FIS season accreditation to this effect.
- 211.2 The Organising Committee**  
The Organising Committee consists of those members (physical or legal) who are delegated by the organiser and by the FIS. It carries the rights, duties and obligations of the organiser.
- 211.3 Organisers which hold competitions involving competitors not qualified under art. 203 - 204 have violated the International Competition Rules and measures are to be taken against them by the FIS Council.
- 212 Insurance**
- 212.1 The organiser must take out liability insurance for all members of the Organising Committee. The FIS shall provide its employees and appointed officials, who are not members of the Organising Committee (e.g. equipment controller, medical supervisor, etc.), with liability insurance when they are acting on behalf of the FIS.
- 212.2 Before the first training day or competition, the organiser must be in possession of a binder or cover notes issued by a recognised insurance company and present it to the Technical Delegate. The Organising Committee requires liability insurance with coverage of at least CHF 1 million; whereby it is recommended that this sum is at least CHF 3 million; this sum can be increased according to decisions of the FIS Council (World Cup etc). Additionally, the policy must explicitly include liability insurance claims by any accredited participant, including competitors, against any other participant including but not limited to officials, course workers, coaches, etc.

212.3 All competitors participating in FIS events must carry accident insurance, in sufficient amounts to cover accident, transport and rescue costs including race risks, as well as an appropriate third-party liability insurance. The National Associations are responsible for adequate insurance coverage of all their competitors sent and inscribed by them.  
The National Ski Association or their competitors must be able to show proof of the respective insurance coverage at any time on request of the FIS, one of its representatives or the organising committee.

212.4 All trainers and officials inscribed and sent to FIS events by a National Association must carry accident and third-party liability insurance, in sufficient amounts to cover accident, transport and rescue costs from damages caused. The National Ski Association or their trainers and officials must be able to show proof of the respective insurance coverage at any time on request of the FIS, one of its representatives or the organising committee.

## **213 Programme**

A programme must be published by the organisers for each competition listed in the FIS Calendar which must contain the following:

213.1 name, date and place of the competitions, together with information on the competition sites and the best ways of reaching them,

213.2 technical data on the individual competitions and conditions for participation,

213.3 names of principal officials,

213.4 time and place for the first team captains' meeting and the draw,

213.5 timetable for the beginning of the official training and the start times,

213.6 location of the official notice board,

213.7 time and place for the prize-giving,

213.8 final date of entry and address for entries, including telephone, telefax and e-mail address.

## **214 Announcements**

214.1 The Organising Committee must publish an announcement for the event. It must contain the information required by art. 213.

214.2 Organisers are bound by the rules and decisions of the FIS in limiting the number of entries. A further reduction in entries is possible under art. 201.1 provided it is made clear in the announcement.

214.3 Postponements or cancellations of competitions and programme alterations must be communicated immediately by telephone, e-mail or telefax to the FIS, all invited or entered National Ski Associations and the appointed TD. Competitions moved to an earlier date must be approved by the FIS.

## **215 Entries**

- 215.1 All entries must be sent so that the Organising Committee receives them before the final date of entry. The organisers must have a final and complete list not later than 24 hours before the first draw.
- 215.2 National Ski Associations are not permitted to enter and draw the same competitors in more than one competition on the same date.
- 215.3 Only National Ski Associations are entitled to make entries for international competitions. Every entry should include:
- 215.3.1 code number, name, first name, year of birth, National Ski Association;
- 215.3.2 an exact definition of the event for which the entry is made.
- 215.4 Entries for FIS World Championships (see Rules for the Organisation of FIS World Championships).
- 215.5 The entry of a competitor by the National Ski Association for a race shall constitute a contract solely between the competitor and the organiser and shall be governed by the Athletes Declaration.

## **216 Team Captains' Meetings**

- 216.1 The time and location of the first team captains' meeting and of the draw must be shown in the programme. The invitations for all other meetings have to be announced to the team captains at their first meeting. Emergency meetings must be announced in good time.
- 216.2 Representation by a substitute from another nation during discussions at team captains' meetings is not allowed.
- 216.3 The team captains and trainers must be accredited by the organisers according to quota.
- 216.4 Team captains and trainers must obey the ICR and the decisions of the Jury and must behave in a proper and sportsmanlike manner.

## **217 Draw**

- 217.1 Competitors' starting order for each event and each discipline is decided according to a specific formula by draw and/or point order.
- 217.2 The competitors entered by a National Ski Association will only be drawn if provided written entries have been received by the organiser before the closing date.
- 217.3 If competitors are not represented at the draw by a team captain or trainer, they will only be drawn if it is confirmed by telephone, telegram, e-mail or telefax by the beginning of the meeting that the competitors who are entered will participate.
- 217.4 Representatives of all the nations taking part must be invited to the draw.

217.5 If a competition has to be postponed by at least one day, the draw must be done again.

## **218 Creation and Distribution of Digital Content**

### **218.1 Introduction**

Information and data are an essential part of understanding and presenting sport, both as a means of measuring and reporting on athletic performance and communicating and promoting sport to the public. FIS, as the international body governing the sports of Skiing and Snowboarding, and with the cooperation of its National Ski Associations, is entrusted for the development, management and accuracy of data related to their common activities.

As an important part of the promotion of Skiing and Snowboarding, FIS encourages National Ski Associations to provide their members, stakeholders and fans with data and information related to FIS activities.

All National Ski Associations are encouraged to provide general information relating to the events and competitions on the FIS calendar, for use by interested parties,

The purpose of this Rule is to define digital content and identify how it can be exploited.

### **218.2 Definition of Digital Content**

Digital Content shall mean all information related to FIS activities, which is made available in a digital form.

Digital Content is comprised of two elements:

- basic written digital content that is freely available, in the public domain and can be used without restriction. This includes documentary archives, reports, rules, official calendars, start and results lists including names of competitors, competition and venue information, running orders, statistics, rankings and standings and information regarding weather conditions, and
- specialist digital content which includes real time information provided by the Official Data and Timing Providers, athlete biographical information and performance data, event and other related content produced by stakeholders, including content on the social media sites of athletes, sponsors and officials

Also included are all video archives for which exploitation rights are available.

Digital content includes all formats, together with any graphical, textual, video or other representations of such data, information and statistics.

### **218.3 Ownership of Digital Content**

The ownership of digital content is determined by the relevant permissions and the contractual relationship, if any, under which such content has been produced and the conditions to be applied for its exploitation.

#### **218.4 Use of Specialist Digital Content**

The development of digital technology has made it possible for the consumer to have instant access to specialist digital content that enhances the viewing experience and interest in sport.

Access to moving pictures can stimulate interest in FIS competitions, and the inclusion of live timing and data feeds adds to the attraction of any video production. Use of the live timing and data feeds on World Cup and World Championships competitions is subject to obtaining the agreement of the owner of these feeds.

#### **218.5 Access to Specialist Digital Content**

Each party seeking to access specialist digital content must find an agreement with the owner/rights holder of the digital content and defining the terms and conditions under which this content can be used. In all cases, and particularly with regard to personal data, a strict adherence to the GDPR or other equivalent law or regulation must be enforced.

The FIS shall advise anyone seeking to use specialist digital content, the name of the owner/rights holder and provide contact numbers.

Should individual owners/rights holders of specialist digital content consider it appropriate, their content could be bundled and offered centrally to the market using the FIS as their representative.

#### **218.6 Review**

In view of constant change and development in technology this rule will be kept under constant review and when appropriate updated on a regular basis.

### **219 Prizes**

219.1 The detailed rules concerning the awarding of prizes will be published by the FIS. Prizes shall consist of mementos, diplomas, cheques or cash. Prizes for records are forbidden. The FIS Council decides in the autumn on the minimum respectively maximum values of the prize money approximately one and a half years before the competition season. The organisers have to inform the FIS by October 15<sup>th</sup> of the amount.

219.2 If two or more competitors finish with the same time or receive the same points, they shall be given the same placing. They will be awarded the same prizes, titles or diplomas. The allocation of titles or prizes by drawing lots or by another competition is not allowed.

219.3 All prizes are to be awarded no later than the final day of a competition or event series.

### **220 Team Officials, Coaches, Service Personnel, Suppliers and Firms' Representatives**

In principle these regulations apply to all disciplines, taking into consideration the special rules.



- 220.1 The Organising Committee of an event must provide the Technical Delegate with a list of persons accredited to the competition.
- 220.2 It is forbidden for suppliers and for persons in their service to advertise inside the restricted area or to wear clearly visible commercial markings on their clothing or equipment which do not conform with art. 207.
- 220.3 Team officials accredited service personnel and suppliers receive from the FIS an official FIS accreditation and must perform their specified function. The individual organisers are free to accredit additional company representatives or other important persons.
- 220.4 Only persons who have the official FIS accreditation or a special accreditation from the organiser for course or jumping-hill have access to the courses and jumping-hills (according to special rules of the discipline).
- 220.5 The Different Types of Accreditation**
- 220.5.1 Technical Delegates, the Jury, and the persons mentioned in art. 220 with clearly visible accreditation have access to the courses and jumping-hills.
- 220.5.2 Servicemen attached to teams are permitted entry to start area and service area at the finish. They are not allowed entry to the courses or jumping-hills.
- 220.5.3 Company representatives accredited at the discretion of the organisers who do not have FIS accreditation are not permitted entry to the courses and restricted service areas.

## **221 Medical Services, Examinations and Doping**

- 221.1 National Ski Associations are responsible for the fitness of their competitors to race. All competitors, male and female are required to undergo a thorough evaluation of their medical health. This evaluation is to be conducted within the competitor's own nation.
- 221.2 If requested by the FIS Medical Committee or its representative, competitors must undergo a medical examination before or after the competition.
- 221.3 Doping is forbidden. Any offence under these FIS Anti Doping Rules will be punished under the provisions of the FIS Anti-Doping Rules.
- 221.4 Doping controls may be carried out at any FIS competition (as well as out-of-competition). Rules and procedures are published in the FIS Anti-Doping Rules and FIS Procedural Guidelines.
- 221.5 Gender of the Competitor**
- If any question or protest arises as to the gender of the competitor, FIS shall assume responsibility for taking the necessary steps to determine the gender of the competitor.
- 221.6 Medical Services Required from Event Organisers**
- The health and safety of all those involved in a FIS competition is a primary concern of all event Organisers. This includes the competitors as well as volunteers, course workers and spectators.

The specific composition of the medical support system is dependent on several variables:

- The size, level, type of the event being held (World Championships, World Cup, Continental Cup, FIS-level, etc.) together with the local medical standards of care and geographic locations and circumstances.
- The estimated number of competitors, support staff and spectators
- The scope of responsibility for the Event Medical Organisation (competitors, support staff, spectators) should also be determined.

The Organiser / The Chief of Medical and Rescue Services must confirm with the race director or technical delegate that the required rescue facilities are in place before starting the official training or competition. In the event of an incident, or issue that prevents the primary medical plan from being utilized, the back-up plan must be in place before recommencing the official training or competition.

The specific requirements concerning facilities, resources, personnel and team physicians are contained in the respective discipline rules and the FIS Medical Guide.

## **222 Competition Equipment**

- 222.1 A competitor may only take part in a FIS competition with equipment which conforms to the FIS Regulations. Competitors are responsible for the equipment that they use (skis, snowboard, bindings, ski boots, suit, etc). It is their duty to check that the equipment they use conforms to the FIS specifications and general safety requirements and is in working order.
- 222.2 The term competition equipment encompasses all items of equipment which the competitor uses in competitions. This includes clothing as well as apparatus with technical functions. The entire competition equipment forms a functional unit.
- 222.3 All new developments in the field of competition equipment must be approved in principle by the FIS.  
The FIS does not take any responsibility for the approval of new technical developments, which at the time of introduction may contain unknown risk to the health or cause an increase in the risk of accidents.
- 222.4 New developments must be submitted by May 1<sup>st</sup> (Grass Ski August 1<sup>st</sup>) at the latest, for the following season. The first year new developments can only be approved provisionally for the following season and must be finally confirmed prior to the subsequent competition season.
- 222.5 The Committee for Competition Equipment publishes equipment by-laws after approval by the FIS Council (definitions or descriptions of the equipment items which are allowed).  
In principle unnatural or artificial aids which modify the performance of the competitors and/or constitute a technical correction of the individual's physical predisposition to a defective performance, as well as competition equipment which impact the health of the competitors or increase the risk of accidents are to be excluded. This article does not apply to Para athletes.

## **222.6**

### **Controls**

Before and during the competition season or on submission of protests to the Technical Delegate at the competition concerned, various controls can be carried out by members of the Committee for Competition Equipment or official FIS Equipment Controllers. Should there be a well-founded suspicion that regulations were violated, the equipment items must be confiscated immediately by the controllers or Technical Delegates in the presence of witnesses and be forwarded sealed to the FIS, which will submit the items to a final control by an officially recognised institution. In cases of protest against items of the competition equipment, the losing party will bear the investigation costs.

No testing of equipment or material in independent laboratories may be requested at races where a FIS Technical Expert has performed the controls, unless it can be demonstrated that the controls have not been carried out according to the rules.

#### **222.6.1**

At all FIS events where official FIS measurement experts using the official FIS measurement tools are appointed, the result of measurements carried out at the time are valid and final, irrespective of previous measurements.

## **222.7**

### **Prohibited of scientific and medical Equipment at FIS Events**

It is prohibited for any National Ski Association, its representative or team member to bring and/or use any of the following scientific or medical equipment ("Equipment") into/at any Event Venue during FIS World Championships, World Cups and other competitions registered in the FIS Calendar:

- Oxygen tanks, cylinders and related devices;
- Hypoxic or hyperoxic tents, chambers and related devices;
- Cryogenic chambers for whole body cryotherapy and related devices.

It is the responsibility of the National Ski Association to ensure compliance with this Article 222.7 by all its representatives or team members. Failure to respect this Article 222.7 will be subject to Penalties provided by Article 223.3. In case of recurrence, disqualification of an athlete shall be imposed irrespectively of whether the violation of this provision would result in an advantage for the Athlete(s) with regard to the end result of the competition. In addition to the sanctions listed above, the FIS may order the immediate removal of the Equipment from the Event Venue at the costs of the responsible NSA.

## **222.8**

### **Fluorinated ski wax prohibition**

Use of fluorinated wax or tuning products containing fluorine is prohibited for all FIS disciplines and levels.

Fluorinated wax can be a competitive advantage and its use in competition will result in disqualification (see competition rules and equipment specifications).

## **223 Sanctions**

### **223.1 General Conditions**

223.1.1 *An offence for which a sanction may apply and a penalty be imposed is defined as conduct that:*

- is in violation or non-observance of competition rules, or
- constitutes non-compliance with directives of the jury or individual members of the jury in accordance with 224.2 or
- constitutes unsportsmanlike behaviour

223.1.2 *The following conduct shall also be considered an offence:*

- attempting to commit an offence
- causing or facilitating others to commit an offence
- counselling others to commit an offence

223.1.3 *In determining whether conduct constitutes an offence consideration should be given to:*

- whether the conduct was intentional or unintentional,
- whether the conduct arose from circumstances of an emergency

223.1.4 All FIS affiliated associations, including their members registered for accreditation, shall accept and acknowledge these rules and sanctions imposed, subject only to the right to appeal pursuant to the FIS Statutes and ICR

### **223.2 Applicability**

223.2.1 *Persons*

These sanctions apply to:

- all persons who are registered with or accredited by the FIS or the organiser of an event published in the FIS calendar (an event) both within and without the confines of the competition area and any location connected with the competition, and
- all persons who are not accredited, within the confines of the competition area

### **223.3 Penalties**

223.3.1 *The commission of an offence may subject a person to the following penalties:*

- Reprimand - written or verbal
- Withdrawal of accreditation
- Denial of accreditation
- Monetary fine not more than CHF 100'000.--
- A time penalty

223.3.1.1 FIS-affiliated associations are liable to the FIS for the payment of any fines and incurred administrative expenses imposed on persons whose registration or accreditation they arranged.

223.3.1.2 Persons not subject 223.3.1.1 also are liable to the FIS for fines and incurred administrative expenses. If such persons do not pay these fines, they shall be subject to a withdrawal of any permission to apply for accreditation to FIS events for a period of one year.

- 223.3.1.3 Payment of fines is due within 8 (eight) days following their imposition.
- 223.3.2 *All competing competitors may be subject to the following additional penalties:*
- Disqualification
  - Impairment of their starting position
  - Forfeiture of prizes and benefits in favour of the organiser
  - Suspension from FIS events
- 223.3.3 Competitors shall only be disqualified if their mistake would result in an advantage for them with regard to the end result, unless the Rules state otherwise in an individual case.
- 223.4 A jury may impose the penalties provided in 223.3.1 and 223.3.2, however they may not impose a monetary fine of more than CHF 5'000.-- or suspend a competitor beyond the FIS event at which the offence occurred.
- 223.5 The following Penalty decisions may be given verbally:**
- reprimands
  - the withdrawal of accreditation for the current event from persons who had not been registered with the organiser through their National Associations
  - the withdrawal of the accreditation for the current event from FIS-accredited persons
  - the denial of accreditation to the current event from persons who are within the confines of the competition area or any other location connected with the competition.
- 223.6 The following Penalty decisions shall be in writing:**
- monetary fines
  - disqualification
  - impaired starting position
  - competition suspensions
  - withdrawal of accreditation from persons who had been registered through their National Association
  - withdrawal of accreditation of FIS accredited persons
- 223.7 Written Penalty decisions must be sent to the offender (if it is not a competitor), the offender's National Association and the Secretary General of FIS.
- 223.8 Any disqualification shall be recorded in the Referee's and/or the TD's Report.
- 223.9 All penalties shall be recorded in the TD's Report.

## **224 Procedural Guidelines**

### **224.1 Competence of Jury**

The Jury at the event has the right to impose sanctions according to the above rules by majority vote. In the case of a tie, the Chair of the Jury has the deciding vote.

- 224.2 Within the location, especially during the training and the competition period, each voting Jury member is authorised to issue oral reprimands and withdraw the accreditation which is issued for the current event.

- 224.3 Collective Offences**  
 If several persons commit the same offence at the same time and under the same circumstances, the Jury's decision as to one offender may be considered binding upon all offenders. The written decision shall include the names of all offenders concerned, and the scope of the penalty to be assessed upon each of them. The decision will be delivered to each offender.
- 224.4 Limitation**  
 A person shall not be sanctioned if proceedings to invoke such sanction have not been commenced against that person within 72 hours following the offence.
- 224.5 Each person who is a witness to an alleged offence is required to testify at any hearing called by the Jury, and the Jury is required to consider all relevant evidence.
- 224.6 The Jury may confiscate objects that are suspected of being used in violation of equipment guidelines.
- 224.7 Prior to the imposition of a penalty (except in cases of reprimands and withdrawal of accreditation according to 223.5 and 224.2), the person accused of an offence shall be given the opportunity to present a defence at a hearing, orally or in writing.
- 224.8 All Jury decisions shall be recorded in writing and shall include:**
- 224.8.1 The offence alleged to have been committed
- 224.8.2 The evidence of the offence
- 224.8.3 The rule (s) or Jury directives that have been violated
- 224.8.4 The penalty imposed.
- 224.9 The penalty shall be appropriate to the offence. The scope of any penalty imposed by the Jury must consider any mitigating and aggravating circumstances.
- 224.10 Remedies**
- 224.10.1 Except as provided for in 224.11, a penalty decision of the Jury may be appealed in accordance with the provisions in the ICR.
- 224.10.2 If an appeal is not filed within the deadline established in the ICR, the penalty decision of the Jury becomes final.
- 224.11 The following decisions of the Jury are not subject to appeal:**
- 224.11.1 Oral penalties imposed under 223.5 and 224.2
- 224.11.2 Monetary fines less than CHF 1'000.-- (One Thousand Swiss Francs) for single offence and a further CHF 2'500.-- for repeated offences by the same person.

- 224.11.3 Sanctions imposed on competitors in competition format where 2 or more competitors simultaneously compete against one another in the field of play and where elimination heats lead to the determination of the final results.
- 224.12 In all remaining cases, appeals are to be directed to the Appeals Commission, as per the ICR.
- 224.13 The Jury shall have the right to submit to the Appeals Commission recommendations for penalties in excess of monetary fines of CHF 5'000.- and suspensions beyond the event in which the offence occurred (223.4).
- 224.14 FIS Council shall have the right to submit to the Appeals Commission comments with respect to any written penalty decisions by the Jury.
- 224.15 Costs of Proceedings**  
Fees and cash expenses, including travel expenses (costs of the proceedings) are to be calculated comparable to costs paid to TD's and are to be paid by the offender. In the case of a reversal of Jury decisions, in whole or in part, the FIS covers all costs.
- 224.16 Enforcement of Monetary Fines**
- 224.16.1 The FIS oversees the enforcement of monetary fines and the costs of proceedings. Enforcement costs are considered costs of the proceedings.
- 224.16.2 Any outstanding monetary fines imposed on an offender is considered a debt of the National Association to which the offender is a member.
- 224.17 Benefit Fund**  
All monetary fines are paid into the FIS Youth Promotion Fund.
- 224.18 These rules are not applicable to any violation of FIS Doping rules.
- 225 Appeals Commission**
- 225.1 Appointments**
- 225.1.1 The FIS Council shall appoint from the Discipline Sub-Committee for Rules (or Discipline Committee if there is no Rules Sub-Committee) a Chair and a Vice Chair of the Appeals Commission. The Vice Chair shall preside when the Chair is either unavailable or is disqualified for bias and prejudice.
- 225.1.2 The Chair shall appoint 3 members to the Appeals Commission from the Discipline Rules Sub-Committee or Discipline Committee for each case appealed or submitted to be heard, which may include the Chair, whose decisions shall be by majority vote.
- 225.1.3 To avoid either actual bias and prejudice or the appearance of bias and prejudice, members appointed to an Appeals Commission shall not be members of the same National Association as the offender whose case is under appeal. In addition, members appointed to an Appeals Commission must report voluntarily to the Chair any bias and prejudice they may hold for or against the of-

fender. Persons who are biased and prejudiced shall be disqualified from serving on the Appeals Commission by the Chair or, in the event the Chair is disqualified, by the Vice Chair.

## **225.2 Responsibility**

225.2.1 The Appeals Commission shall only hold hearings with respect to appeals by offenders or by the FIS Council from decisions of competition juries, or matters referred to it by competition juries recommending penalties in excess of those provided for in the Sanction rules.

## **225.3 Procedures**

225.3.1 The Appeal must be decided within 72 hours of receipt of the Appeal by the Chair, unless all parties involved in the Appeal agree in writing to an extension of time for the hearing.

225.3.2 All appeals and responses must be submitted in writing, including any evidence the parties intend to offer in support of or in response to the Appeal.

225.3.3 The Appeals Commission shall decide on the location and format for the Appeal (phone conference, in person, e-mail exchanges). The Appeals Commission members are required to respect the confidentiality of the appeal until the decision is made public and to consult only with the other members of the panel during the deliberations. The Chair of the Appeals Commission may request additional evidence from any of the parties involved, providing this does not require disproportionate means.

225.3.4 The Appeals Commission shall allocate costs of the appeal pursuant to 224.15.

225.3.5 Decisions of the Appeals Commission may be announced orally at the conclusion of the deliberations or hearing should one take place. The decision, together with its reasoning, shall be submitted in writing to the FIS, which shall deliver them to the parties involved, their National Associations and all members of the Jury whose decision was appealed. In addition, the written decision shall be available at the FIS Office.

## **225.4 Further Appeals**

225.4.1 Decisions of the Appeals Commission may be appealed to the Court of Arbitration CAS for Sports (CAS) in accordance with Article 16.7.6 of the Statutes.

225.4.2 Appeals to the CAS shall be in accordance with the Code of Sports-related Arbitration.

225.4.3 An Appeal to the Appeals Commission or to the CAS will not delay the implementation of any penalty decision of the Competition Jury, Appeals Commission or Council.



## 226

### **Violation of Sanctions**

Where there is a violation of a sanction that has been imposed (according to ICR 223 or the FIS Anti-Doping Rules, the Council may impose such further and other sanctions that it considers appropriate.

In such cases, some or all of the following sanctions may apply:

#### 226.1

##### **Sanctions against individuals involved:**

- a written reprimand;

*and/or*

- a monetary fine not to exceed the sum of CHF 100'000.--

*and/or*

- competition suspension at the next level of sanction - for example if a three month suspension for a doping offence was imposed, a violation of the suspension will cause a two year suspension; if a two year suspension for a doping offence was imposed, a violation of the suspension will cause a life-time suspension;

*and/or*

- withdrawal of accreditation from individuals involved.

#### 226.2

##### **Sanctions against a National Ski Association:**

- withdrawal of FIS funding to the National Ski Association;

*and/or*

- cancellation of future FIS events in the country involved;

*and/or*

- withdrawal of some or all FIS membership rights, including participation in all FIS calendar competitions, voting rights at the FIS Congress, membership of FIS Committees.

---

## 2<sup>nd</sup> Section

---

### Joint Regulations for Nordic Combined Competitions

#### 500 Organisation

#### 501 The Competition Committee and Officials

##### 501.1 Members

- the chief of competition
- the competition secretary
- the chief of hill
- the chief distance measurer
- the chief of calculations
- the chief of course
- the chief of timekeeping
- the chief of stadium and competition control
- the chief of security
- the chief of technical facilities
- the chief of equipment and
- the chief of first aid services

Additional officials may be appointed to the Competition Committee as specific needs arise.

##### 501.2 The Officials and their Duties

###### 501.2.1 *The Chief of Competition*

is responsible for the preparation of all technical and administrative aspects of the competition. He directs, controls and monitors the work of all officials. He chairs the Team Captains' Meeting in coordination with the Technical Delegate (TD) / Race Director (RD).

He directs on assignment of the Jury the technical aspects during both official trainings and the competition.

###### 501.2.2 *The Competition Secretary*

is responsible for all administrative and secretarial work associated with the competition and is in charge of preparing for other officials all forms, lists, and tables, including start lists, result lists, minutes of the team captains meeting, and informational bulletins on the competition. The competition secretary also accepts any protests arising from the competition and works as secretary of the Jury.

###### 501.2.3 *The Chief of Hill*

is responsible for the preparation of the jumping hill. He coordinates and controls the work of the chief of the inrun and the chief of the landing area. During both, training and the competition, he remains in continual contact with the chief of the competition and keeps him informed about hill conditions.

#### 501.2.4

##### *The Starter*

is responsible to ensure that all participants start from the designated start place in the proper order and within the designated start time.

Whenever a competitor violates the rule for the starting procedure, the starter must immediately report to the Jury.

At OWG and WSC there is an additional start referee. He has to supervise that the starting procedure is carried out correctly and controls any infringements. He has to ensure that no unauthorized persons are present in the start area. He has authority over the starter and his assistant.

#### 501.2.5

##### *The Chief of the Inrun*

is responsible for the preparation of the takeoff and the inrun.

He ensures for a high quality of the prepared (mechanical or manual) inrun track and secures the presence of sufficient equipments to clean the inrun track by special conditions (e.g. strong snow fall).

During the competition, the chief of the inrun observes and controls the entire length of the inrun. In the case of a fall or an obstruction on the inrun, the Jury uses information from the chief of the inrun to determine whether to allow the competitor a re-jump.

On jumping hills not equipped with automatic start lights, the chief of the inrun must position an assistant at the takeoff to give the signal that the hill is clear. This assistant receives the signal to open the jump from the chief of competition.

#### 501.2.6

##### *The Chief of the Landing Area*

is responsible for preparing the landing slope and the outrun area with manual packing and grooming techniques with suitable skis (alpine skis) or mechanical equipment.

#### 501.2.7

##### *Forejumpers*

###### *The Chief of Forejumpers*

is responsible for testing the in-run with the help of forejumpers prior to the start of the training and the competition, as well as for keeping the track clear during the event under changing conditions e.g. snowfall. The chief of forejumpers will be informed by the chief of competition how many forejumpers are required and at what time they should be prepared to jump.

###### *Forejumpers*

The National Ski Association of the respective competition organizer is responsible for providing qualified forejumpers that are available each official training/competition day: at least eight (8) for WC and six (6) for the other competition categories during the winter and five (5) for summer competitions on all levels. They are not classified in the competition. However, they must be capable of starting from the gate established by the jury for the event. The minimum age limit that applies to competitors according to the rules of the corresponding competition series also applies to the forejumpers. The minimum age for ski flying competition is 18 (art. 546.3)

Forejumpers must be registered by their National Ski Association, have signed the FIS athletes' declaration, must meet all of the criteria of ICR Article 215

and must observe all ICR provisions and other FIS rules referring to competitors.

The Jury is entitled to appoint additional forejumpers from the non-qualified competitors, but they must be registered by the respective National Ski Association according ICR Article 215.

#### 501.2.8 *The Chief Distance Measurer*

The responsibilities of this position are as follows:

- the correct placement of the distance markings on both sides of the landing hill (art. 514.1.1)
- the placement of measurers according to ICR Rules and of the distance recorder (art. 514.1.3).

The chief distance measurer must supervise the efforts of distance measurers. He must arrange the measurers in such an order that the least experienced and skilled are situated above the P point of the landing hill. He must constantly oversee the reporting by measurers of the distances jumped and the communication of these distances to calculations personnel and the public announcer.

Before the competition, the chief distance measurer shall instruct distance measurers in the measuring techniques to be used.

It is mandatory for each distance measurer to be present during the training prior to the competition in order to receive the instruction of the chief distance measurer. Non-participation during this training shall bar the measurer from acting in the role as a measurer for the competition.

#### 501.2.9 *The Chief of Calculations*

is responsible for the calculation of the results. Together with his assistants the chief of calculations is responsible for the quick collection of the basic scoring data and making a quick and correct calculation. With the Chief of timekeeping he is responsible for the official final result.

#### 501.2.10 *The Chief of Course*

is responsible for a optimal course preparation and has the knowledge how to use the course preparation equipment related to different snow conditions. He should be familiar with the course homologation requirements.

He is responsible for the preparation of the ski-testing areas, warm-up tracks, the marking and fencing of the course, temperature measurements, first aid posts, feeding stations, and for providing the facilities for intermediate timing.

He uses the course preparation groups and the forejumpers to ensure the course is in the best possible condition and he must send at least two course closers or a vehicle around the course after the last competitor.

#### 501.2.11 *The Chief of Timekeeping*

is responsible for the direction and coordination of the officials working in the timing area. He supervises manual timers, electronic timers, intermediate timekeepers and calculations officials' work. He coordinates the work of the starter and the finish referee with the chief of stadium. He supervises the data processing services and supports the distribution and collecting of transponders.

The chief of timekeeping and data processing oversees the preparation of the Timing and Data Technical Report (TDTR) and xml file for the electronic transmittal to FIS following the competition. A copy of the report may also be printed (only if the TD has no access to his report) for review prior to the transmission of the xml file. The TDTR Software can be found on the FIS website.

501.2.12 *The Chief of Stadium and Competition control*

is responsible for all activities in the stadium area and the controllers along the course. This includes flow of competitors to the start and flow from the finish area. He is responsible to provide fencing, course markings and signs in the stadium area, to coordinate the placement of the start and finish lines with the chief of timekeeping.

He decides together with the chief of competition and the TD on the suitable placing of controllers, he informs the controllers of their duties and equips controllers with control cards and other material that may be necessary and assigns them to their locations. After the competition he must collect all pertinent information and control cards and reports any incidents to the Jury. He coordinates with the chief of control and competition security for the effective stadium access and control for competitors, coaches, service personnel and the media.

501.2.13 *The Chief of Security*

is responsible for ensuring that persons not involved in running the competition are kept at a safe distance from the specified area and zones so that the competitors, competition officials and additional officials with accreditation do not interfere with or disturb the work of the officials. He ensures that only authorized personnel are allowed access to specified area and zones at the competition area. He coordinates his activities with the chief of stadium, chief of hill and the chief of course. For OWG, WSC, WCNC and JWSC competitions, he is responsible for security and access into and along the course, in team preparation areas and in the stadium area.

501.2.14 *The Chief of Technical Facilities*

is responsible for the control and orderly functioning of all technical systems and devices used during the competition. This official shall ensure that the following are functioning properly:

- devices to measure and display the jumping distances, the inrun and wind velocities
- internal telephone or radio communication lines
- the electronic-scoreboard display of start numbers, distances jumped, style points, and overall points of each participant.
- the start and finish equipments
- loudspeakers at the competition area
- all systems of artificial inrun cooling

501.2.15 *The Chief of Equipment*

is responsible for supplying proper equipment and competition support items to the chief of competition. The chief of equipment must also work closely with

the chief of competition before the competition to make sure that the proper equipment and tools will be on hand during the competition.

**501.2.16**      *The Chief of Medical and Rescue Service*

is responsible for the treatment of first aid for everyone at both the official training and the competition – competitors, spectators, officials, etc. This official is also responsible for establishing emergency procedures for transportation to a medical facility. Specific responsibilities include ensuring that proper medical teams and the necessary medical equipment are present during both official training and the competition (at the jumping hill and the Cross-Country area). Details of the Medical Support Requirements are given in chapter 1 of the FIS Medical Guide containing Medical Rules and Guidelines.

**502**            **The Jury and Competition Management**

**502.1**           **The Jury**

*502.1.1*        *The Jury consists of the following members:*

- the Technical Delegate (TD) as chairman
- the Chief of Competition
- the Assistant of the TD

**502.1.2**       **The Duties of the Jury**

The Jury must ensure that the entire competition, including the official training sessions, are organised and carried out in accordance with the Rules of the International Competition Rules (ICR).

The Jury must decide:

- The need to interrupt, postpone or cancel the competition.
- All protests, disqualifications, sanctions and questions that occur during the competition and are not covered or not covered completely by the ICR Rules and Regulations.
- The checking and recognition of late entries.

*502.1.2.1*     *Duties for Ski Jumping*

From which maximum inrun-length the jumpers must start. The length of the inrun must be determined in such a way, that the jumping hill is used to its full capacity.

For the competition, the Jury is required to meet, once a jump has reached 95 % of the established Hill Size (HS) to consider whether the round of jumps is to continue. The Jury must decide whether the round in progress can be continued with the same inrun speed, or whether it must be cancelled and repeated from a lower starting gate. If the jumps are too short, the round can be stopped, cancelled, and re-started from a higher gate.

In the event that the so-called Wind/Gate Compensation System is in place, the in-run length can also be changed within a competition round (see art. 525.1.2).

In which sphere of the wind condition (velocity) the jumper is allowed to start.

About the starting order for a competitor who is either when delayed arriving at the start due to „force majeure“, or concerning a re-jump for a competitor who has been obstructed (see art.522.4, 525.1.13, 525.1.14)

In cases in which the Jury cannot make an immediate decision the jump or re-jump may be provisionally granted. This decision must be announced to the public.

Substitution and late Entries see art. 522.4

#### 502.1.2.2 *Duties for Cross-Country*

If the temperature is below –20 °C, measured at the coldest point of the course (see art. 514.4), the competition will be postponed or cancelled by the Jury. With difficult weather conditions (e.g. strong wind, high air humidity, heavy snowfall, or high temperature) the Jury may, in consultation with the Team Captains of the participating teams and the Chief of medical and rescue service responsible for the competition, postpone or cancel the competition. The checking and recognition of a reserve course, if the homologated course can not be used due to poor snow conditions.

#### 502.1.3 **Decisions of the Jury**

All decisions by the Jury must be made by open vote and a resolutions-protocol must be drawn up on all decisions which were taken. Each member has one vote. All the decisions of the Jury require plain/simple majority.

The members must vote (agreement or rejection, abstention is not possible) with the following exceptions:

– member is prevented from voting due to „force majeure“.

In case of a tie, the respective chairman of the Jury has the decisive vote.

#### 502.2 **The Competition Management**

502.2.1 At OWG, SWC, WCNC and GPNC competitions the Competition Management consists of:

- the Race Director FIS (RD)
- the Technical Delegate (TD)
- the Chief of Competition
- the Chief of Course
- the Assistant of the TD
- the Assistant of the RD
- the Equipment Controller

502.2.2 At COCNC competitions the Competition Management consists of the following members:

- the COCNC Coordinator
- the Technical Delegate (TD)
- the Chief of Competition
- the Chief of Course
- the Assistant of the TD

- 502.2.3 For University Winter Games (UWG) the Competition Management consists of the following members:
- the FISU Race Director (appointed by FISU)
  - the Technical Delegate (TD), who is the chair of the Jury (appointed by FIS)
  - the Chief of Competition
  - the Chief of course
  - the Assistant of the TD (appointed by FIS)

## **503 FIS Officials for Jury and Competition Management**

Normally jury members should arrive at the venue early enough to have 2 full working days before first competition day.

The TD is responsible that all Jury duties are carried out and should distribute tasks among Jury members according to their abilities and experience.

Jury members should be able to ski the course and make a judgment of the course preparations.

### **503.1 The FIS Technical Delegate (TD)**

503.1.1 TDs are appointed for all Nordic Combined competitions on the FIS Calendar (nomination art. 505). The TD is responsible for ensuring that the competition is carried out in accordance with ICR Rules and with the appropriate Cup Competition Regulations.

At OWG, WSC, JWSC, WCNC, GPNC and COCNC events the TD cannot in general be a member of the host Nation's Ski Association; however, the FIS Council may make exceptions to this rule.

The TD is obliged to uphold the decisions of the Nordic Combined Committee and must possess a valid license at the time of appointment.

#### *503.1.2 Requirements and Qualifications*

A TD candidate must have an extensive background in support roles for officials and must also be able to communicate clearly in the official FIS language of English. The TD candidate's National Ski Association submits the candidate's qualifications to the Sub-Committee for Officials, Rules and Control for review. The qualification for a new candidate is to take part on two consecutive FIS-seminars. When starting this qualification period, the candidate should be under 43 years of age. The Nordic Combined Committee will grant exceptions to this rule in well-substantiated cases in which the National Ski Association files a petition for admission on behalf of the candidate.

The guidelines for TD qualifications as ratified by the FIS Council are valid for certification as a TD. Candidates for TD are not entitled to reimbursement for their expenses during the qualification period.

#### *503.1.3 Examination and License*

After completing all requirements for qualification and participation at the first FIS-seminar, the candidate is granted admission to the examination.

After passing the examination, the candidate will receive a license; this license consists of a passbook.



After successful passing the second seminar and examination the passport will be declare valid and the new TD gets a TD badge. Between the first and the second examinations the candidate must have practical experience at the national level.

#### 503.1.4 *Further Qualification and Revocation*

To retain a FIS license, a TD must participate every two years in a certification course organised by the FIS.

A TDs license will be revoked if the TD fails to work as an assigned TD for two consecutive years without justified cause. Re-appointment and certification are possible only after the FIS receives a letter of support from the National Ski Association's chairman of officials and the head course instructor verifies the TDs successful participation in a FIS TD certification course. The re-appointment has to be confirmed by the Sub-Committee for Officials, Rules and Control.

Once a TD reaches the age of 65, they are automatically removed as a FIS-TD.

#### 503.1.5 *The Duties of the Technical Delegate:*

##### 503.1.5.1 *Before the Competition*

The TD must contact the Organising Committee in advance of the event and know the stage of preparation the organiser has reached. The TD should arrive at the venue early enough to inspect the preparation of the hill and cross-country course and assess the organisational readiness (art. 503).

The TD must inspect the homologation documents (jumping/cross-country). It is the responsibility of the organiser to provide the TD with a copy of the hill and cross-country certificates without being asked.

The inspection points to be covered by the TD include the following:

- the organisation of the event, lodging conditions, meals, transportation, preparation and working conditions for the media, for the preparation of team captains meeting must be inspected.
- the jumping hill(s). The preparation of the hill, the conformity of the hill's actual profile to the certificates, jumpers' safety, and measuring devices must be reviewed.
- technical and organisational planning for the jumping competition. The TD must assess working conditions for Judges, distance measurers, and calculation personnel; he must also evaluate the communication network (telephone and radio), the coaches' stand, the scoreboard display, start lights, start control, first aid services, and spectator control.
- to control of all technical devices
- to control the cross-country course, stadium, check profile, stadium layout, start and finish zone and fencing for all these zones.
- technical check of organisational planning for the cross-country competition (timekeeping, video-control, photo finish)
- the competition program: Inspection must cover training times, team captain meetings, draw, the competition schedule, medical service doping control, equipment control, and the awards ceremony.
- Jury: Working conditions, identification, communication

- checking the liability insurance (art. 212.2)

The TD has the authority to ask the Organising Committee for any support deemed necessary to the fulfilling of these tasks

#### 503.1.5.2 *During the Competition*

##### 503.1.5.2.1 *Ski Jumping*

It is the responsibility of the TD to ensure that the competition is carried out in accordance with ICR Rules.

- Check substitutions and late entries, art. 522.4
- Decide on all reported infractions including ICR 207 and late starts (if force majeure was the reason for late start), art. 525.1.13
- Inform teams on Jury decisions
- Decide on valid protests
- Document Jury decisions along with used evidence to be used in case of appeal

The TD must be present throughout the entire competition and must be located in the Judges tower. It is essential that the TD has a direct communication line with the Jury-members, thereby making it possible for quick and accurate decisions by the Jury.

Immediately after the competition the results and the start list for the cross-country race must be checked (Gundersen method).

##### 503.1.5.2.2 *Cross-Country*

On the competition day the TD must be informed about the preparations at the cross-country area within the appropriate time. He has to check if competitions start as scheduled (stadium and course preparation, weather conditions, teams on site?). He must control all points at the start and finish area; he must supervise the start process and be in connection with all Jury-members. At the Mass Start competition he must check immediately after the race the results and the start list for the jumping competition.

- 503.1.5.2.3 Whenever a problem arises that is not completely covered in ICR Rules or arises from a concern of Jury members, the TD must initiate both the discussion and the decision-making processes.

##### 503.1.5.3 *After the competition*

Immediately after the competition ends, the TD is responsible for the final Jury-meeting, where the conclusion of the competition or decisions of the protests are prepared in writing. The TD must do the report on all aspects of the event. The report shall consist of the designated report form and any additional comments deemed relevant. This report shall include but is not limited to a discussion of organisational preparation, preparation of the hill(s), an evaluation of the competitive event, a final results list and a complete set of minutes from all meetings and Jury decisions. Without TD and timing reports the result will not be valid. The report is available online.

## **503.2 FIS Race Director (RD)**

This official is nominated by the FIS for competitions of the highest category (see art. 502.2.1). The FIS Race Director must possess a TD-license for Nordic Combined.

503.2.1 The Duties of the Race Director include:

- Represents the interests of the International Ski Federation.
- Schedules and conducts inspections.
- Supervises that all aspects of the organizer agreement are correctly fulfilled.
- Monitors the proper operation of the event according to the regulations and guidelines of FIS and reports to the Head of Nordic Combined resp. to the Technical Committees.
- Responsibilities for the coordination of all persons and parties involved.
- Coordinates decisions concerning postponements and replacement of an event after cancellations.

The RD has the authority to ask the organizing committee for support deemed necessary to the fulfilling these tasks.

## **503.3 TD-Assistant (TDA)**

503.3.1 The TD-Assistant must possess a TD-license for Nordic Combined. Additionally, he is responsible for the following special tasks:

*in Ski Jumping:*

- Responsible for the correct and due preparation of the competition facility (athletes' area, chairlift, warm up area, starting area, in-run, take off, landing area as well as out run area)
- Inspection of the relevant security installations (sideboards, fences)
- Connection to trainers
- Completion of the TD report with any additional comments deemed relevant

503.3.2 *in Cross-Country:*

- Check the measurements of the course, control the structure and function of elements from the course profile according to the TD report and the installation of the start and finish area
- Control the start lists and the start procedures
- Control of fixed parts of course during the competition
- Evaluation of the control cards from the controllers
- Control of competition equipment and commercial marking
- As well as further, all assignments from the Jury

## **503.4 RD-Assistant (RDA)**

This official is nominated by the FIS for competitions of the highest category (see art. 502.2.1). He must possess a TD-license for Nordic Combined and will be appointed by the RD for specific tasks. Therefore, it's necessary that he arrives at the event site at least one day in advance of the scheduled official jumping training (coordinated with the TD).

Additionally, he is responsible for the following special tasks:

- Placement of the technical systems for the in-run speed measuring and the measuring of the wind velocity.
- Control and monitoring of the technical systems for Ski Jumping and Cross-Country.
- Coordinates and directs the starting procedure for Ski Jumping and Cross-Country.
- Controls the preparation and main parameters of the Cross-Country courses.
- Inspect the preparation of the hill and cross-country course and assess the organisational readiness.

### **503.5 COCNC Coordinator**

This official is nominated by the FIS for COCNC competitions (see art. 502.2.2). The COCNC Coordinator must possess a TD-license for Nordic Combined.

503.5.1 The Duties of the COCNC Coordinator include:

- Represents the interest of the International Ski Federation.
- Supervises that all aspects of the organizer agreement are correctly fulfilled.
- Monitors the proper operation of the event according to the regulations and guidelines of FIS and reports to Committees.
- Responsibilities for the coordination of all persons and parties involved.
- Coordinate decisions concerning postponements and replacement of an event after cancellations.

The COCNC Coordinator has the authority to ask the organizing committee for support deemed necessary to the fulfilling of these tasks.

### **503.6 Equipment Controller**

These officials are nominated by FIS for Cup competitions (WC, COC, GP), see art. 502.2.1. The Equipment Controller must possess a TD-license for Nordic Combined.

503.6.1 The Duties of the Equipment Controller are:

#### *Ski Jumping*

- Responsibilities for the correct preparation and maintenance of the necessary equipment control devices.
- Controls the equipment, records of any infringements and makes reports to the Jury.

#### *Cross-Country*

- Coordination and control of the start procedure.
- Further defined tasks by the Jury.

## **504 Judges and Referees**

### **504.1 Ski Jumping**

#### *504.1.1 Jumping Judges*

The duties, education and nomination of the jumping judges are described in the ICR Book III Ski Jumping, art. 404 and 405. The appointment for competitions in Nordic Combined will be coordinated by the Nordic Combined and Ski Jumping Sub-Committees for Officials, Rules and Control.

#### *504.1.2 Distance Measuring Officials*

For all Ski Jumping competitions listed in the FIS Calendar of events, the distances jumped shall be reported by distance measurers (art. 514.1.3 and 514.1.4).

Each National Ski Association participating in the event may enter one distance measurer as long as the person nominated possesses the required qualifications and performs these duties during all official training periods. Foreign distance measurers are not entitled to reimbursement by the organisers of expenses arising from their assignment.

#### *504.1.2.1 The Distance Measurers*

take their place on one side of the landing hill on the prepared standing positions behind the distance boards according to the measuring area assigned to them by the chief distance measurer. If foreign distance measurers are appointed, they must be assigned to measuring areas between the landing segment P-point down to K-point and must be determined by a draw, which is supervised by the chief distance measurer.

The measuring area of a distance measurer must not exceed the following ranges:

- up to 60% of the Hill Size (HS)                      5 meters
- from 60% to 80% of the HS                              4 meters and
- from 80% to 100% of the HS                            3 meters.

All the distance measurers have the clear responsibility to view the measuring area which they were assigned to, and to note the landing distance within this measuring area immediately and to provide the marked distance clearly to the distance recorder (according to art. 514.1.3) regardless of the actions of the people beside them.

At OWG, WSC, JWSC, WCNC, GPNC and COCNC events video distance measuring will be used, so that the distance measurers who are positioned in the landing segment of the video distance measuring will only be used if there is a technical failure of the video measuring. For this reason, the measuring distance, which these distance measurers are assigned to, can be up to 10 m long, and the distance measurers have to stand higher off to the side. In addition, there must be cross-lines marked every 5 m on the landing hill.

At OWG, WSC, WCNC, GPNC the measuring can be done without distance measurers as long as the recording of all jumps is secured.

#### 504.1.2.2 *Distance Recorder*

The distance recorder shall be located in a suitable location on the landing hill opposite the distance measurers but offers the distance recorder an advantageous position from which to receive reported distances. The distance recorder is responsible for the accurate recording and reporting of jumping distances indicated by the distance measurers. At the conclusion of the competition, the distance recorder must deliver the original Distance Record Chart to the competition secretary for processing and final review by calculations personnel.

### **504.2 Cross-Country**

#### 504.2.1 *Start official Cross-Country*

The starter must ensure that all provided preconditions are fulfilled so that all competitors can start at their correct times.

#### 504.2.2 *Finish Referee*

The finish referee is responsible for keeping a list and a voice recorder (dictaphone) of the order in which the competitors cross the finish line. He gives this list and the tape to the chief of timekeeping.

## **505 Nomination, Reimbursement and Insurance of Competition Officials**

### **505.1 Nominations**

The FIS shall nominate certain officials for international Nordic Combined competitions. Jumping Judges may not be assigned to events in which a family member is participating (grandparents, parents, children, brother, sister, husband, wife).

#### 505.1.1 Olympic Winter Games (OWG), FIS World Ski Championships (WSC), FIS Junior World Ski Championships (JWSC)

For OWG, WSC:

- the TD
- the RD
- the TD-Assistant
- the RD-Assistant
- the Equipment Control
- the Chief Distance Measurer\*
- six Jumping Judges\*

Five at a time, the nominated Jumping Judges will officiate at the respective Ski Jumping competitions at OWG and WSC, taking turns based on a draw decision (in exceptional cases the respective competition management together with the respective Sub-Committee Chair can decide about a different system).

The 6<sup>th</sup> Jumping Judge of the respective competition or competition day will act as start or fall referee (Jury decision).

505.1.2 *For Junior World Ski Championships (JWSC)*

- the TD
- the TD-Assistant
- the Equipment Control
- the Chief Distance Measurer\*
- five Jumping Judges\*

The nomination of all named competition officials is carried out by the FIS Council.

The Jumping Judges nominated must belong to different Ski Associations. One of the Jumping Judges should be a member of the Ski Association of the organising country.

505.1.3 *For World Cup- and Grand Prix Nordic Combined competitions (WCNC, GPNC)*

- the TD
- the RD
- the TD-Assistant
- the RD-Assistant
- the TD national
- the Equipment Control
- the four foreign Jumping Judges and
- one Jumping Judges of the host country

The Nordic Combined Sub-Committee for Officials, Rules and Control nominates the TD, the TD-Assistant and the TD national for the event by name.

The Ski Jumping Sub-Committee for Officials, Rules and Control determines which four National Ski Associations may nominate one of their own qualified Jumping Judges to officiate at the event.

The National Ski Association of the host country shall nominate the remaining Jumping Judge from their own list of qualified Jumping Judges.

505.1.4 *For Continental Cup competitions (COCNC)*

- the TD
- the COC Coordinator
- the TD-Assistant
- the Equipment Control
- the one foreign Jumping Judge
- four Jumping Judges from the host country

The Nordic Combined Sub-Committee for Officials, Rules and Control nominates the TD and the TD-Assistant for the event by name.

The Ski Jumping Sub-Committee for Officials, Rules and Control determines which National Ski Association may nominate one of their own qualified Jumping Judges to officiate at the event.

The National Ski Association of the host country shall nominate the four remaining Jumping Judges.

---

\* see nominations ICR Book III Ski Jumping

**505.1.5** *For International Nordic Combined Competitions (FIS)*

– the TD

The Nordic Combined Sub-Committee for Officials, Rules and Control nominates the TD. The National Ski Association of the host country shall nominate the TD Assistant and the five Jumping Judges.

The TD and the TD-Assistant and the five Judges must possess valid FIS license at the time of appointment.

**505.2** **The Nomination of Substitutes**

Whenever a competition official nominated by the FIS is unable to attend the competition and fulfill an assignment („force majeure“), the official must be replaced. For OWG, WSC, JWSC, WCNC, GPNC and COCNC events, the substitute nomination must be confirmed by the FIS Office.

**505.3** **Reimbursement of Expenses**

The competition Organising Committee is responsible for the cost of travel and accommodation to the following amounts (bank transfer costs and eventual taxes (VAT) and costs have to be paid by the organiser):

**505.3.1** *Travel Expenses*

- first class train fare,
- air fare for longer distances (economy class)
- and/or CHF 0.70 per km for travel by car (car expenses from and to the airport or rail station)
- parking costs

The basis for the calculation of expenses is the official's address in the FIS database. Prior to travel, the nominated competition official must confer with the organiser regarding the travel arrangements (train, plane or car).

If overnight accommodation during the journey to and from the assignment is necessary, this must be justified and reimbursed separately.

**505.3.2** *Daily Allowance*

CHF 125.-- per day of travel to and from the event.

**505.3.2.1** The RD Assistant, TD and the TD Assistant receive in addition CHF 125.– per day for the duration of the event during WSC, WCNC, GPNC, COCNC and JWSC competitions. The same applies to the TD national for WCNC and GPNC competitions. For all other level of international competition refer to art. 505.4.6.

**505.3.2.2** Jumping judges get in addition during WSC, WCNC, GPNC, COCNC and JWSC competitions CHF 125.– per day counted from the 4<sup>th</sup> day of the duration of the event. For all other level of international competition refer to art. 505.4.6.

**505.3.3** *Accommodation*

Free room and board in an adequate hotel at the event.



The stay at the event shall be coordinated with the Organising Committee, including both the days of official training and the days of the competition.

**505.3.4** *Costs for visa*

The costs for obtaining visas have to be paid by the organiser. The reimbursement of costs includes travel costs to the embassy respectively consulate according the ICR art. 505.3.1, travel expenses and the visa costs on receipt.

**505.4** The reimbursement of expenses mentioned above will apply to the competitions and officials listed below:

**505.4.1** *OWG and WSC*

- the TD
- the TD-Assistant
- the RD-Assistant
- the Chief Distance Measurer
- six Jumping Judges

**505.4.2** *JWSC*

- the TD and
- the TD-Assistant

At JWSC, the reimbursement according to the regulations for JWSC shall apply to the following:

- the Chief Distance Measurer
- the five Jumping Judges

**505.4.3** *WCNC and GPNC competitions*

- the TD
- the TD-Assistant
- the RD-Assistant
- the four foreign Jumping Judges

**505.4.4** *COCNC competitions*

- the TD
- the TD-Assistant and
- one foreign Jumping Judge

**505.4.5** *International Nordic Combined competitions (FIS)*

- the TD

**505.4.6** *National nominations for FIS Officials for International Nordic Combined Competitions*

For the nominated TD, TD Assistant and the five Jumping Judges the National Ski Association resp. the Organiser is responsible for providing at least travelling expenses, full board and accommodation during the event according to the national rules.

TD and TD-Assistant get (except the expenses) at least one daily allowance as reimbursement.

## **506 Team Captains' Meeting**

### **506.1 Procedure**

For each competition a team captain meeting is carried out. It should take place one day before the official training and before the competition.

The date, time and place of the team captains' meeting has to be published in the competition program (article 216). In principal two representatives per participating team are allowed to take part in the team captains' meeting.

At OWG, WSC, WCNC and JWSC competitions the seating arrangements of the participating teams have to be marked.

At OWG, WSC, WCNC and JWSC competitions the team captains' meeting shall be held in English. Supplementary translations should be provided.

### **506.2 Agenda**

A written agenda has to be distributed for the team captains' meeting. It is prepared by the competition secretary in cooperation with the chief of competition and the TD.

At all international competitions the agenda normally contains the following items:

- Roll call
- Introduction of the members of the OC
- Introduction of the Jury
- Introduction and draw of the Jumping Judges
- Weather forecast
- Checking of the entries or grouping of the competitors and if necessary draw
- Information to the competition areas (jumping hill, stadium, course, start, finish, exchange zone for relay, security problems, fencings etc.)
- Preparation of Jumping hill and Cross-Country course
- Training and competition program
- Equipment controls
- Medical controls
- General information from TD
- General information from the Organiser
- General information from FIS RD

Minutes which contain all topics of discussion and the recommendations made must be taken at the team captains' meeting.

## 510 The Jumping Hill

### 511 Informatin on the Jumping Hills

511.1 Men's Nordic Combined competitions will be carried out on normal hills, and/or large hills, with ski flying possible, while women's competitions are carried out on normal hills.

#### 511.2 Classification of the Jumping Hills according to sizes

The class of the hill will be determined by the distance of the L-point (HS): Hills are classified by sizes as follows:

Description	Dimension HS	Respective Dimension w
Small hills	to 49 m	to 44 m
Medium hills	50 m to 84 m	45 m to 74 m
Normal hills	85 m to 109 m	75 m to 99 m
Large hills	110 m to 149 m	
Giant hills	150 m to 184 m	
Flying hills	185 m and larger	

Large hills for which the height difference between the lowest point in the out-run and the edge of the takeoff exceeds 88 m will not be homologated by the FIS.

Whenever new twin-hill construction is to take place, the difference between the distances at HS on the normal and large hill should be a minimum of 25 meters.

#### 511.3 The Geometrical Elements for the Jumping Hill (Fig. 1)

##### *Inrun*

- A highest start place
- B lowest start place
- E<sub>1</sub> the beginning of the radius curve
- E<sub>2</sub> the end of the curve, the beginning of the takeoff
- T the edge of the takeoff
- e<sub>1</sub> the length of the inrun from the highest start place to the edge of the takeoff table
- e<sub>2</sub> the length of the inrun from the lowest start place to the edge of the takeoff table
- e<sub>s</sub> the length of the starting place area
- t the length of the takeoff
- $\gamma$  the gradient of the straight section of the inrun
- $\alpha$  the gradient of the takeoff
- r<sub>1</sub> the radius of the curve of the inrun at point E<sub>2</sub>

##### *Profile of Landing Area*

- T the edge of the takeoff of the hill (=coordinate origin)
- s the height of the takeoff
- P the beginning of the landing area
- K construction point
- L the end of the landing area

- U the start of the outrun area, lowest point of the profile
- HS the measured distance (Hill Size) from the edge to the takeoff to the end of the landing area L
- w distance between the edge of the takeoff and the construction point K, measured according to ICR art. 415.1
- h the height difference from the edge of the takeoff to the K point
- n the horizontal distance from the edge of the takeoff to the K point
- $z_U$  the height difference from the edge of the takeoff to the lowest point U
- $l_1$  the length of the curve P-K
- $l_2$  the length of the curve K-L
- $l$  the length of the curve of the landing area P-L
- a the length of the outrun
- $\beta_0$  the tangent angle of the landing hill knoll at the base of the takeoff
- $\beta_P$  the tangent angle at P point
- $\beta$  the tangent angle at K point
- $\beta_L$  the tangent angle at L
- $r_L$  the landing hill radius P-L
- $r_{2L}$  the radius curve at L
- $r_2$  the radius curve at U
- $b_1$  the clear width of the inrun
- $b_2$  width at the base of the takeoff
- $b_k$  the prepared width at the K point
- $b_u$  the prepared width at the end of the  $r_2$  radius and the start of the outrun

Fig. 1

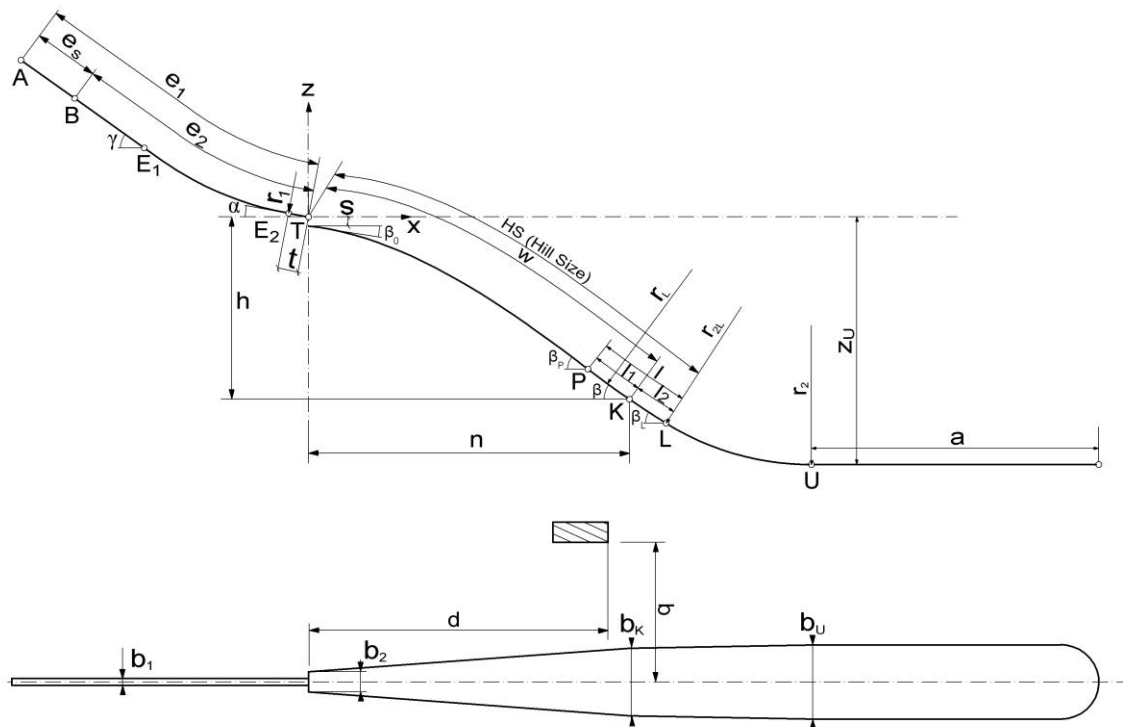

## 512 Information to the Cross-Country courses

### 512.1 Classification of the courses

Competition format	Competition distance (km)	Course length (km)
Individual Gundersen	5.0, 7.5, 10, 12.5, 15	2.0, 2.5
Individual Mass start	5.0, 10	2.0, 2.5
Individual Compact	5, 7.5	2,5
Team	4 x 5.0	2.5
Team-Sprint	2x4.5, 2x7.5	1.5
Mixed Team-Sprint	2x6.0	1.5
Mixed Team	15	2.5

### 512.2 General information

At World Cup competitions, Cross-country courses exceeding the highest point (1800 m) must be approved by the FIS Council.

### 512.3 Norms for the Cross-Country course

Cross-Country courses must be laid out so that they provide a technical, tactical and physical test of the competitors' qualifications. The degree of difficulty should be in accordance with the level of the competition. The course should be laid out as naturally as possible to avoid any monotony, with rolling undulating sections, climbs, and downhill sections.

Rhythm should not be broken by too many sharp changes in direction or steep climbs. The downhill sections must be laid out so they challenge the competitors. At the same time it should be possible to ski the course even under fast snow conditions.

### 512.4 Competition course

In principle, the Cross-Country course should consist of:

- One-third up hills defined as climbs with a gradient between 9% (1:11) and 18% (1:5.5) with height differences over 10 meters plus some short climbs steeper than 18%

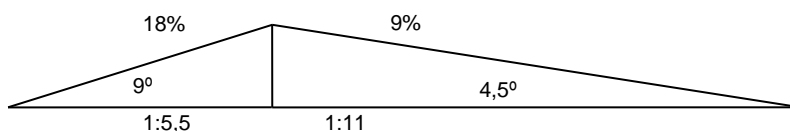

- One-third undulating, rolling terrain, utilizing all terrain features with short climbs and downhills (with height differences of 1-9 meters).
- One-third varied downhills, demanding versatile downhill techniques.

The courses may only be used in the direction established for the competition.

## 512.5 Technical parameters of the Cross-Country courses

### 512.5.1 Height Difference (HD)

The difference in height (HD) between the lowest and highest points of a

1500 m	25 m (for a Team-Sprint / Mixed Team-Sprint course)
2000 m	40 m
2500 m	50 m
3750 m	60 m

### 512.5.2 Maximum Climb (MC)

The maximum length difference of a single climb (PHD) must not exceed these limits but can be interrupted by a section of undulating terrain that does not exceed 200 m in length or a down hill that does not exceed 10 m. PHD.

1500 m	25 m (for a Team-Sprint / Mixed Team-Sprint course)
2000 m	40 m
2500 m	45 m
3750 m	50 m

### 512.5.3 Total Climb (TC)

The total climb (TC) should be within:

5 km	150 – 210 m
7.5 km	220 – 255 m (for a Team-Sprint / Mixed Team-Sprint course)
10 km	250 – 400 m
15 km	400 – 550 m

### 512.5.4 Description of Uphills

The uphill is defined by the Partial Height Difference (PHD). PHD is the height difference from the lowest to the highest point of the uphill. Additional description of the uphill is given by the Partial Climb (PC). PC is the total climb of the uphill. Sum of all PCs is the Total Climb (TC) of the course.

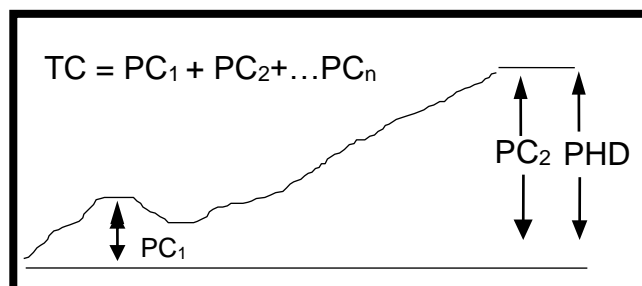

## 512.6 Course Design

Ideally the course should consist of several laps, so that spectators are entertained by repeated appearances of the competitors in the stadium.

## 512.7 Homologation

The homologation of Nordic Combined Cross-Country tracks will be carried out by the Nordic Combined Sub-Committee for Officials, Rules and Control

based on the Cross-Country ICR Book II art. 311 and 312 and the Cross-Country Homologation Manual.

## **513 Working conditions at the Competition areas**

### **513.1 At the Jumping Hill**

#### *513.1.1 Judges Tower*

The following requirements in and around the judges tower must be fulfilled:

- Ensure that enough space for Jury and additional staff (TV, Data-Service, technical equipment wind measuring system, Info PC, start control)
- Contact to the environment (it must be possible to open the window)
- The view to the start, to the take off and landing area including the out-run
- Communication to all important points and officials on the jumping hill
- Judges compartments
- Room for the announcer

#### *513.1.2 Coaches Stand*

For jumping hill facilities, where international competitions are to be organized, coaches must have two suitable stands (for 20 persons each) One stand should be in the area near the edge of the take off and the second should have an unobstructed view of the jumpers' flight and landing.

For OWG, WSC and WCNC events, coaches' stands for 40 coaches must be available.

#### *513.1.3 The Ski Jumping Hill Infrastructures*

For OWG, WSC, JWSC and WCNC competitions the infrastructure requirements are regulated in the FIS matrix, available in the document library of the FIS Website.

### **513.2 Cross-Country Stadium**

513.2.1 A Cross-Country stadium has to be prepared for OWG, WSC, JWSC and WCNC competitions, with a well-designed start/finish area.

513.2.2 The stadium arrangement should provide a functional entity divided and controlled as necessary by gates, fences and marked zones. It must be prepared in such a way that:

- the competitors may pass through it several times
- competitors, officials, media, service people and spectators may reach their respective areas easily
- there is enough space to carry out Individual starts, Team starts, and mass starts and the finish can be as wide and long as required.

513.2.3 Competitors should be able to reach the following areas, without being disturbed:

- the team preparation area (wax cabins)
- the ski testing area and the warm-up tracks

- the equipment control and transponder distribution
- the storage for warm-up clothing
- the start
- the through lap or relay/Team-Sprint exchange (with exit)
- the finish
- the immediate care area (tents for the exchange of clothes, refreshments etc.)
- the exit

513.2.4 Competition officials and Jury members must have proper working conditions. Coaches, officials, media and service people must have proper working zones within the stadium area so that they can work without disturbing the process of start and finish. The access of these persons to the stadium area must be regulated by accreditations.

513.2.5 *Jury Room*

At OWG, WSC, JWSC and WCNC competitions, FIS officials and Jury members must be provided a working room in the immediate vicinity of the stadium.

513.2.6 *Timekeeping Building*

Timekeeping and calculation should be located in a building with a good view of the start and finish.

513.2.7 *Ski Test Area*

A ski glide testing area with tracks for all participating teams must be located near to the stadium. It should also be in close proximity to the team wax cabins and warm up track.

**513.3 Requirements for Competition areas**

513.3.1 *Team areas and wax cabins*

For OWG, WSC, JWSC, WCNC and COCNC a secured team preparation area with wax cabins equipped with electrical current supply must be installed in the immediate vicinity of the Jumping hill and the stadium.

513.3.2 *Medical Services Room*

See specifications of the Medical Committee in the Medical Guide.

**514 Measuring Devices**

**514.1 Ski Jumping**

514.1.1 *Jumping Distances*

Distance markings shall be placed on both sides of the landing from the distance of 0.5 K to the HS. To correctly position the distance markings, take a measuring tape, and measure from the two sides of the takeoff edge down the landing slope to the point that is 50% of the K-point (w rounded up to a full m). At this measured point, fasten the appropriate distance marking on both



left and right sides of the landing slope. Measure along the slope in 1 m intervals to mark the location of the other distance markings.

For the measuring of the distances with a technical system (technical distance measuring), the approval of the Jumping Committee is required for its operational validity.

#### 514.1.2 *Definition of Jumping Distance*

The distance to be awarded is measured from the edge of the takeoff to the point where the jumper touches the landing slope. The landing is considered complete when both feet are in full contact with the landing slope. For abnormal landings (one foot landing, e.g. one foot on the snow and the other remaining in the air noticeably longer than it would take for a normal landing) the distance measured will be the point where the first foot is in full contact with the landing slope.

The landing point is that point, where at this time the feet of the athlete are positioned. If there is a distance between both feet, the middle between the legs is the relevant point.

If the landing does not proceed by placing the skis on the snow (a fall), the distance measured will be the point where any part of the jumper's body first touches the landing slope.

#### 514.1.3 *Measuring of the Jumping Distance by the Distance Measurers*

The distance measurers stand on one side of the landing slope and follow the jumper's trajectory with their eyes up to the landing point. The measurer in whose measuring area the viewed jump landed shall mark the jumping distance to an accuracy of 0.5 m. The mark to be awarded is indicated by the placement of the measurer's hand on the distance markings. Half meters are indicated by an additional rising of the free arm. The distance markings shall be placed on both sides of the landing slope to prevent parallax mistakes by the markers.

#### 514.1.4 *Measuring of the Jumping Distance by the Technical Measures*

Technical measuring devices that measure distances to an accuracy of 0.5 meter and tabulate the distance are permitted for the recording of the jumping distance and the calculation of distance points.

Distances must also be practically measured by distance measurers as a back-up and in case of mechanical failure of the technical measuring device.

#### 514.1.5 *Inrun Speed*

The devices for the measurement of inrun velocity ( $v_0$ ) shall be placed as follows:

- the measured distance of the photocell beam is 8 m
- the second photocell beam must be located 10 m before the edge of the takeoff
- the photocell beam must be 0.2 m above the snow profile

For jumping hills listed on the FIS competition calendar Hill Size (HS) 85 m and larger, inrun velocities must be measured during all training periods and throughout competition.

#### 514.1.6 *Wind Velocity and Direction*

The wind measuring instruments must be placed alongside the landing slope at the height of the optimal flight trajectory. The measurement data for these devices must be available to competition officials in the Judges Tower and shown in the most consolidated, readable form possible. Measuring instruments must be placed in three locations on normal and large hills (at the edge of the takeoff as well as at approximately 50% and approximately 100% of the distance to the K-Point). In addition, at least 8 wind flags or wind socks must be placed along each side of the landing hill at the height of the flight trajectory. The Jury can change the locations of some of these devices if specific conditions on the hill require it.

If the wind/gate application is used there are special rules relating to the fixation of wind measuring devices.

#### 514.1.7 **Start Permission and Start Time Control**

##### 514.1.7.1 *Three phase mode*

Start permission and starting time control at OWG, WSC, JWSC, WCNC, GPNC as well as COCNC will be determined by means of a three-coloured (red-yellow-green) stoplight and a digital clock which are connected and running automatically depending on the adjustable starting rhythm program.

During the red phase (start preparation) the clock runs backward from the adjusted time to zero seconds. The red phase is for the direction of the competition and can be stopped whenever needed. During the consecutive yellow phase, the clock runs forward. The competitor is allowed to take the position on the starting bar with the begin of the yellow phase. According to the external conditions the Jury decide about the minimal duration of the yellow phase (usually between 10 and 15 seconds). The duration of the yellow phase can be between 10 and 60 seconds. If the conditions do not allow to start the competitor, the yellow phase switches to red automatically. In this case the competitor must leave the starting bar and prepare for the new starting procedure. The yellow phase switches to the green phase after 10 seconds at the earliest. With the switching to green light the starting time begins and will be finished after 10 seconds. Within these 10 seconds the competitor must start and leave the starting bar. The light automatically switches back to red and the starting procedure for the next jumper begins.

The times for yellow and red phase must be clearly visible to the athletes on the separate display on the starting semaphore.

##### 514.1.7.2 *Two phase mode*

The start permission and the start time control FIS events must be done with an automatically controlled light signal (traffic light). The light shall be a steady green for 5 seconds, a flashing green for a minimum of 5 seconds up to a maximum of 10 seconds.

After the entire start time period of a minimum of 10 seconds up to a maximum of 15 seconds, a red light thereafter. The established start time period must be clearly visible to the athletes. The countdown of starting time may also be shown by an automatically directed clock.

The chief of competition, an assigned assistant or a Jury member is responsible for controlling the start-time device.

#### 514.1.8 *Lengths, Angles, and Temperatures*

The following measuring devices and instruments must be available on site for the TD and the TD Assistant at all times:

- a 50 m measuring tape
- a hydrostatic balance (digital level)
- a balance bar
- a goniom
- a thermometer
- a metric tape measure (minimum 3 m).

These measuring devices will allow the TD to review the actual and current snow profile, snow temperature, and air temperature.

### 514.2 **Measuring Devices for Cross-Country**

For all competitions listed in the FIS Calendar, electronic timekeeping is mandatory. Electronic timing will always be supported by hand timing as a backup system and the results cross checked between the two systems.

#### 514.2.1 *Timekeeping – Start*

The Gundersen start is carried out without an electronic start gate. In order to guarantee an exact start, a large display digital clock must be used. The clock is started by zero time when the first competitor starts. At the same time, the starters must start an additional stop watch for control. The starting procedure must be recorded by a HD video camera which focused to the clearly marked starting line (see marking start line, art. 515.2.7).

As a backup system for OWG, WSC and WCNC an additional transponder line has to be placed 1,5 m beyond the starting line. The reference time for the Jury to check the start procedure is 1 second, which means all earlier starts must be checked.

#### 514.2.2 *Intermediate Time*

An intermediate timing point will be established according to the local circumstances and the respective length of the course. In principle it should be 1 – 2 intermediate timing points per round.

#### 514.2.3 *Finish Timing*

Times will be measured in full tenths of a second. Times to one hundredth of a second will not be used.

When using hand timing, the time is taken when the competitor's first foot crosses the finish line.

In case of electronic timing, the time is taken when the contact is broken. The measuring point of the light or photo barrier must be at a height of 25 cm above the snow surface.

Additionally, the finish is to be recorded by video cameras. The first camera must be positioned on one the side of the finish line providing a picture of the finish and an additional camera positioned to identify the starting bibs.

#### 514.2.4 *Photo-Finish camera*

At OWG, WSC and WCNC special Photo-Finish cameras (Line-CCD) must be employed to record the correct order of finish. To attain a correct and swift result evaluation, it is imperative that every competitor wears an additional starting bib on the outside of his thigh where the camera position is. The height of the starting bib digits should not be less than 8 cm.

The Line-CCD camera must be able to register finish line crossing with a 1/1000 s precision. The CCD camera must be synchronised with the main timing system 1/2 hour before competition starts. The display of the time behind the winner or display of the running time is sufficient.

In the case of Photo-Finish decisions, the image of the Line-CCD camera must be presented on the system monitor to the Jury, additionally a colour print-out with time scale is required.

This system is subject to FIS homologation.

#### 514.2.5 *Photo-Finish*

The use of technical measurements (Video camera, Line-CCD camera) shall be used in the following situations for the determination of the actual final ranking:

- if the finishing times are identical
- a difference in the finish ranking list made by the finish referees
- the difference between two or more athletes crossing the finish cannot be clearly witnessed.

### **514.3 Transponder Timekeeping**

Transponders (active and passive systems) can be used as a supporting system to the official timing system to determine race times and ranking sequences at intermediate timing points, pre-timing points, and finish (unofficial result).

The official result must be confirmed by using electronic timing systems in accordance with ICR 514.3.1.

For Gundersen competitions the order at the finish is the ranking criteria for the official result. The finish order must be confirmed in any case with the photo finish system. In case of usage of transponders, the determined finish times can be used for the official result when the finish order is confirmed by photo finish system.

#### 514.3.1 *Electronic Timing*

The following electronic timing technologies can be used to identify the official finish times:

- Electronic timing system based on photo cells. The measuring point of the light or photo barrier must be at a height of 25 cm above the snow surface.
- Photo finish system. The measuring point will be the toe of the first boot meeting the finish line.

## **514.4 Current Information Facilities**

A notice board is showing the air and snow temperature. These temperatures must be displayed at the following times: Two hours before the start, one hour before the start, half an hour before the start, at the start, half an hour after the start, and one hour after the start.

Temperature measurements must be taken in the stadium area and at places where extreme temperatures (low points, high points, windy, shady or sunny places) can be expected, see art. 502.1.2.2

Notice boards must be used for intermediate times and unofficial results.

Loudspeakers must be used for announcing the competition and other important information concerning the event.

In order to inform competitors, trainers, spectators, etc., at least one language (English or German) must be used in addition to the Organiser's language.

## **515 Preparation of the Competition areas**

### **515.1 Ski Jumping Hill**

#### *515.1.1 General Snow Preparation*

Before the start of official training and throughout the entire competition period, the hill – from the start point at the top of the inrun to the end of the outrun – must be prepared in exact accordance with the requirements.

#### *515.1.2 Requirements for the Inrun and Takeoff*

The preparation of the snow must be such that it is completely level and at the exact height of the profile boards. This profile should allow a snow depth of 20 cm minimally. The necessary snow density is achieved through packing.

The tracks must be prepared with the help of technical equipment (a track cutter, track plane or inserted profile boards or something similar) according to the following measurements:

- Distance between both centers of tracks for Jumping hills with  $w$  over 75 m: 30 - 33 cm
- Width of track: 13.0 - 13.5 cm
- Depth of track: at least 3 cm for normal, large and flying hills

The following regulations are valid for OWG, WSC, JWSC, WCNC events:

- In winter, the in-run tracks must be prepared with artificial snow, ice or in exceptional cases artificial material (i.e. china).
- The in-run tracks prepared with artificial snow or ice have to be supported by a cooling system.
- The track has to be made by track cutters
- It has to be assured that surface water caused by rain or warm weather can be drained from the track.

The preparation of the inrun and takeoff must provide all competitors with the same conditions throughout each competition round. If it is necessary to change or prepare the inrun during the competition because of snowfall, falls, or long holds, there must be a sufficient number of trial jumps before the competition can continue. In the case of poor and hazardous conditions, the Jury

will base its decision on the performance of the trial jumpers and the effects of the weather on them.

If the length or inclination of the takeoff is changed during one official round of competition, the round must be cancelled and restarted.

It is the Jury's responsibility to decide at the conclusion of a day of jumping whether the inrun track shall be left in or taken out and the inrun prepared anew.

#### 515.1.3 Requirements for the Landing Slope and Outrun

The snow must be prepared so that it possesses the necessary density and firmness. The snow depth must be a minimal of 30 cm (35 cm for the hills with plastic covering).

For sites hosting OWG, WSC, JWSC and WCNC competitions, it is mandatory that the preparation, grooming and packing of snow will be accomplished through the use of an appropriate on-site snow grooming machine.

Chemicals may be used to ensure that the necessary firmness can be achieved. The prepared snow surface shall be completely level and concur with the planned (designed) snow profile. This requirement is extremely important for the area from the first distance paddle to U (end of transition curve).

#### 515.1.4 *The Marking of the Landing Hill*

The Hill Size (HS) has to be marked on the landing hill by a crossline of spruce twigs or equivalent. This crossline should be marked with red ink colour at each side of the landing slope for a distance of 5 meters. Furthermore, on both sides of the landing slope it is recommended that banners with different colours shall be laid down as follows:

- between the construction point (K) and the Hill Size (HS) a red banner on each side;
- from the K-point towards the P-point a blue banner on each side in an equivalent length of the distance between K and HS, as well as
- from the fall line towards the HS a green banner on each side in an equivalent length of the distance between K and HS.

For the orientation of the measurers, Jumping Judges and spectators regarding distances reached and for calibrating the video-distance measuring, crosslines also have to be placed on the landing slope from 10 m before P-point to the Hill Size (HS) for the jumping lengths at intervals of five m (e.g. 60 m, 65 m, 70 m, 75 m, 80 m...). If needed, the Jury is entitled to add additional markings.

The guidelines for the Construction Requirements for the Jumping Hill that Serve the Elements of Competition and Safety are given with in the ICR book III Ski Jumping, art. 411.5.

#### 515.1.5 *Fall Line*

It is the responsibility of the Jury to define the placement of the fall line on the outrun. After this decision has been reached, a crossline shall be marked with either a painted line or spruce twigs. As a rule, the fall line shall be located at the lowest point on the  $r_2$ .

## 515.1.6 **Hybrid competition**

In exceptional cases during the winter season, competitions can be held using an artificial snow or ice track system in combination with a plastic covered landing hill.

However, the following officials must approve the approach beforehand

- the Chair of the FIS Nordic Combined Committee
- the FIS Race Director and
- the FIS Secretary General

## 515.2 **Cross-Country Course**

### 515.2.1 *Pre-Season Preparation*

Rocks, stones, roots, stumps, brush and similar obstacles should be removed. The courses must be prepared before the winter so that they can be raced even with very little snow. Sections of the course that have drainage problems must be corrected. The summer preparations should be of a standard which allows for carrying out of competitions with approximately 30 cm of snow. Special attention must be given to downhill sections and the need for banking the curves.

### 515.2.2 *General Snow Preparation*

The course should be completely prepared with mechanical equipment. If heavy machines are used, they should follow the original configuration of the ground as much as possible in order to preserve the undulations of the terrain.

### 515.2.3 *Preparation for Free Technique*

The course must be prepared to the recommended width from 6 to 8 m. The course must be prepared so that competitors can ski and pass unobstructed. On slopes where the trails traverse, they must be wide enough to allow for good preparation.

### 515.2.4 *Preparation for Mass Start*

The first 30–50 m after the start will be prepared with parallel tracks where each competitor is forbidden to leave the track and is forbidden to use skating techniques. The next 50–100 m (without tracks) should be like a funnel until the normal width of 6–8 m is reached. Narrow sections along the course must be eliminated.

### 515.2.5 *Preparation for Training*

The courses must be completely prepared before the official training, correctly marked and with the kilometer signs in place. The testing tracks should have the same preparation as the competition course.

### 515.2.6 *Employment of Chemical*

All use of artificial means in order to improve the glide on the snow are forbidden. In special situations, the use of chemicals to preserve a solid surface is permitted.

#### 515.2.7

##### *Start Area*

The start must be prepared according to the terrain, with the first 100–200 m prepared to a width at 6–9 m.

In order to guarantee an exact start, there must be a large start clock placed so that it is easily readable from the start line and a board with the starting numbers and starting times for each starting lane must be used. The clock is started by zero time when the first competitor starts. At the same time, the starters have to start an additional stop watch for control.

The start line must be clearly marked by a coloured line. The use of coloured planks with a width of max. 10 cm placed lower than the prepared snow is recommended. This start line must be placed at right angles to the skiing direction.

#### 515.2.8

##### *Individual Gundersen- and Individual Compact Competition*

The start must be prepared so that in principle three (3) competitors may start side by side.

#### 515.2.9

##### *Mass Start*

The start layout for a Mass start competition is prepared in a straight line. The distance between each track in the starting area should be 1.2 – 1,5 m. If there are more competitors in any one group than there are start lanes, then the higher start number will be positioned in the next row. The distance between the rows should be 2 m. To ensure a fair starting procedure, additional modifications due to the terrain and snow conditions can be made.

Start number 1 starts on the middle track, no. 2 to his right, no. 3 to the left of the middle track etc.

#### 515.2.10

##### *Team Gundersen and Mixed Team Gundersen Competition*

The start must be prepared so that in principle two (2) competitors may start side by side.

#### 515.2.11

##### *Team Gundersen and Mixed Team Gundersen Competition Exchange Zone*

The Team Gundersen Competition and Mixed Team Gundersen exchange zone should be a rectangle 30 meters long and sufficiently wide, clearly marked (the beginning and end of the zone must be marked with 1 m long red line on the right and left side and with signs “Exchange Zone Start” and “Exchange Zone End”) and roped off and located on flat or smoothly rising terrain near to the start and finish (special regulation art. 542.3.)

#### 515.2.12

##### *Team-Sprint and Mixed Team-Sprint Exchange Zone*

The Team Sprint and Mixed Team Sprint exchange zone should be a rectangle 30 to 40 meters long or of equal lengths the boxes and sufficiently wide, clearly marked (the beginning and end of the zone must be marked with 1 m long red line on the right and left side and with signs “Exchange Zone Start” and “Exchange Zone End”) and roped off and located on flat or smoothly rising terrain near to the start and finish (special regulation art. 543.3).



### 515.2.13 *Marking the Course*

The marking of the course must be clear so that the competitor is never in doubt where the course goes. At OWG and WSC the colours of the markings have to be determined and described in the course descriptions.

### 515.2.14 *Marking the Course - Kilometer signs*

Kilometer signs must mark the accumulated distance skied along the course. At OWG, WSC and JWSC competitions, every kilometer must be marked. For all other FIS competitions, this marking should be done whenever possible.

### 515.2.15 *Marking the Course - Barriers*

Forks and intersections on the course must be marked clearly by visible signage and fences must be placed across unused parts of the course.

### 515.2.16 *Course Protection*

At OWG, WSC, JWSC and WCNC competitions the courses must be fenced along both sides at all places where spectators can potentially interfere with the competitors.

### 515.2.17 *Structure of Finish Area*

The layout of the finish area in Nordic Combined consists of the home stretch, as straight as possible to the finish line approx. 100–150 m and the finish zone which is the last straight 50 to 100 m before the finish line. The beginning of this zone must be clearly marked. This zone is a minimum of 9 m wide and is separated in at least 3 corridors that must be clearly marked and highly visible but do not interfere with the skis.

### 515.2.18 *Marking Finish Line*

The finish line must be clearly marked by a coloured line with a width of max. 10 cm. The use of coloured planks (v-boards) placed lower than the prepared snow is recommended. The finish line must be placed at a right angle to the incoming finish lanes.

## **516 Information for Spectators and Press**

### **516.1 Information for Spectators**

In addition to receiving information via the public address system, competitors and spectators should be informed by electronic scoreboards.

The scoreboard shall display the competitor's start number, the distance jumped, the style score given by each Judge, the total point score, and current place in the competition. The scores of the five Judges must be published at the same time.

At the Cross-Country competition the scoreboards must show the intermediate times and the ranking with the time differences.

## 516.2 Stands for Media Representatives

Optimal working conditions and places shall be provided for representatives from television, radio, newspapers, periodicals, and photography agencies. These conditions shall include continuous information (start lists, current positions and changes of ranking), access to optimal viewing positions, and an assigned area equipped with trouble-free technical devices to facilitate the performance of their duties.

The use of flashbulbs or other lighting devices is prohibited during the jumping competition, for these devices can interrupt and disturb jumpers and their movements.

## 520 Competition and Competitors

### 521 Requirements of the Competitors

#### 521.1 Age Classification of Competitors

The following age classifications have been established for FIS Nordic Combined competitions:

- Youth I and II
- Juniors up to 20 years of age on 1<sup>st</sup> January of the current calendar year.
- Seniors: all competitors over the age limit for juniors.

#### **Youth Competitors**

	<b>Youth I</b>	<b>Youth II</b>
<i>Season</i>	<i>Years of birth</i>	<i>Years of birth</i>
2023/24	2009, 2010, 2011	2006, 2007, 2008
2024/25	2010, 2011, 2012	2007, 2008, 2009
2025/26	2011, 2012, 2013	2008, 2009, 2010

#### **Nordic Junior World Ski Championships**

A competitor must have reached their 16<sup>th</sup> birthday before the end of the calendar year (1<sup>st</sup> January – 31<sup>st</sup> December) in question.

<i>Season</i>	<i>Age</i>	<i>Years of birth</i>
2023/24	16-20	2004, 2005, 2006, 2007, 2008
2024/25	16-20	2005, 2006, 2007, 2008, 2009
2025/26	16-20	2006, 2007, 2008, 2009, 2010

#### **OWG, WSC, WC, SGP and COC**

Competitors must have reached their 16<sup>th</sup> birthday before the end of the calendar year (1<sup>st</sup> January – 31<sup>st</sup> December) in question:

<i>Season</i>	<i>Years of birth</i>
2023/24	2008 and earlier
2024/25	2009 and earlier
2025/26	2010 and earlier

#### 521.1.1

In OWG, WSC and World Cup competitions, all competitors shall start in one category.

521.1.2 For all other international Nordic Combined competitions, separate age groups may be established. The entry form must advise participants what the various age groups will be.

521.1.3 Junior competitors may start in the Senior category provided their National Ski Association has entered their name in that category. However, Juniors wishing to start in this category must have the skills to compete in the Senior class.

521.1.4 *Qualification WSC*

For participation at WSC an athlete must fulfil the following qualification criteria:

- regular participation in WCNC, COCNC or other Cup systems
- JWSC or Youth events and
- **the athlete** must participate in a national competition system.

## **522 Entry**

522.1 Each National Ski Association must enter their competitors for international competitions according to the final entry date or by the participation conditions within the official FIS entry form.

### **522.2 Competition Entry**

At OWG, WSC and JWSC two hours prior to the designated team captains' meeting, each nation must present at the race office the starting order of their competitors by name. This entry form must contain:

FIS Code / Family name / first name / Club / year of birth / starting group or ranking position.

In exceptional cases the Jury may shorten this time period.

### **522.3 Entry by Team**

Entry for the nations as per the rules art. 522.2. The entry by competitor's name and position for the first discipline must be made two hours prior to the team captain's meeting, for the second discipline immediately after the end of the first competition but no later than 15 min. after the announcement of unofficial result. In exceptional cases the Jury may shorten or extend these time periods.

### **522.4 Entering Substitution and Late Entries**

#### *522.4.1 Late Entries*

A late entry in a Gundersen competition is possible only if it occurs prior to the start of the jumping competition and in a Mass Start competition prior to the start of the Cross-Country race.

#### *522.4.2 Substitution*

After the draw, a competitor can only be substituted if he can not start due to force majeure (injury, illness, etc.) and if the Jury permits the substitution. This has to be certified by a medical doctor and communicated to the Jury until 2 hours before the start.

- 522.4.3 In case of an accident during warming up, the Jury can permit a substitute later than 2 hours before the start (injury confirmed by a medical doctor).
- 522.4.4 If the withdrawn competitor was selected for doping control then this test must still be carried out and must also be carried out on the substitute competitor. If the withdrawn competitor produces a positive test, no substitute will be allowed.
- 522.4.5 The Jury has to make also the decision, in which place in the starter field the substituted competitor may start (e.g. in the same place, in it's ranking position or at the beginning of a group).  
Exception: The substitute athlete must start in the same Team/Team Sprint position as the substituted athlete. The Team's starting order cannot be changed.
- 522.4.6 Competitors, who are on the starting list and cannot take part in the competition because of illness or other reasons, must be reported by the team captain to the competition secretary at latest 30 min. before the start. If any of these competitors were selected for doping control, they must still be tested.

## **523 Draw**

### **523.1 Principles**

- 523.1.1 For international competitions, the draw is carried out by using a random double selection.
- 523.1.2 It is possible to have the draw conducted prior to the team captains' meeting under the supervision of the Jury.

### **523.2 Individual Competitions**

#### *523.2.1 Gundersen and Compact method*

The starting order at OWG, WSC, WCNC and COCNC in Ski Jumping for the official trainings, provisional competition round, trial and competition round will be based on the reverse order of the actual Cup standings. Competitors without any points in the Cup Standings will be drawn in groups before those competitors with points.

The starting order for the JWSC is based on the reverse order of the actual WC/COC standings. Competitors without any points in the Cup Standings will be drawn in groups before those competitors with points (the number of groups is the decision of the jury).

For the EYOF/YOG competitions, competitors will be seeded into 4 (EYOF) and 2 (YOG) groups (I, II, III, IV) and will be drawn into their respective groups.

#### *523.2.2 Mass Start*

The start order by Mass Start competitions is based on the actual Cup standings. The leader of the ranking list will receive the first number. Competitors without any points will be drawn in groups at the end of the start field.

523.2.3 FIS Competitions  
At competitions without ranking lists, the start order is realized by draw. The Jury must decide on the number of groups and the number of athletes per nation within a group based on the field size.

### **523.3 Team Competitions**

523.3.1 For OWG, WSC and WCNC competitions the start order of Team competitions will be based on reverse order of the actual Nation's Cup standings (the starting order for the Mixed Team competitions will be based on the reverse order of the total sum of the Nation's Cup standings men and women).

By equal point standings the start order will be made by draw in the team captain's meeting between the equal placed teams. Teams without Nation's Cup points or rankings start in the beginning of the competition. The start order must be made by draw.

For JWSC the start order is determined according to the reverse ranking from the previous JWSC.

523.3.2 *FIS Competitions*

The start position will be made by draw or as per a special rule.

## **524 Training before the Competitions**

### **524.1 Ski Jumping**

524.1.1 All training on the competition jumping hill before the competition (official training) must be within the schedule assigned by the OC and under the supervision of the Jury.

Any additional training made independently under self responsibility and/or direction of a trainer (free training) during the scheduled organisation days is not permissible.

524.1.2 At the official training for the competition only the registered competitors as well as the additional fore jumpers specified by the Competition Committee can participate.

At the OWG, WSC, JWSC and Cup competitions the right to participate during the official training is based on the actual rules and regulations.

524.1.3 For FIS International competitions, OWG, WSC and JWSC the jumping hills must be available for training a minimum of one day/session. The Competition Committee shall consider both snow and weather conditions when scheduling training sessions. It is the responsibility of the Competition Committee to provide optimal training conditions for all competitors.

524.1.4 If possible, training sessions shall be scheduled at the same time of day as the competition. All information pertaining to the training schedule or possible changes must be presented in due time.

524.1.5 The jumping hill must be in good condition for all training sessions and must be prepared as it would be for the competition. An adequate number of officials and hill packers must be present during the training sessions.

524.1.6 During all training sessions, distances shall be supervised and the maximum length of inrun decided and fixed by the Jury.

524.1.7 On-site first-aid personnel must be present during all training sessions to provide any necessary medical assistance.

524.1.8 To guarantee an equal opportunity, both jumping hills are to be closed for training and competition 14 days prior the first training day of the OWG respectively WSC.

The competition dates have to be scheduled in such a way that all trainings/sessions, according to the above articles are realized on the first jumping hill to be used prior to the first competition, subsequent training on the same hill for the second competition is additional. The same condition must be present for training days prior to the second jumping competition on the new jumping hill.

## **524.2 Cross-Country**

Competitors and team officials should be given the opportunity to train and inspect the course in competition conditions. When possible, the course should be open two days before the competition. The Jury may close the course or limit the use of the course to certain sections or hours.

## **525 Competition Realisation**

### **525.1 Ski Jumping**

#### *525.1.1 Number of Jumps*

For all competitions, with exception of the IG 15 km (two scored competition rounds Ski Jumping), one competition round in Ski Jumping will be held which will give the calculation basis for the converted time difference for the Gundersen method and **the fixed start intervals for the Compact format**. One trial jump (round) must be included in the competition program. The decision to use the trial jump is up to the jumper.

#### *PCR - Junior World Ski Championships (JWSC)*

The provisional competition round (PCR) will be carried out according to the regulations for a competition round. The scores can be used as a result for the start of the Cross-Country race only if the actual competition round Ski Jumping cannot be carried out. This score can be used only one time.

#### *525.1.2 In-Run Length*

The Jury shall decide the length of in-run (starting place) to be used. Once a majority decision has been reached on the start to be used, its length must remain the same for the entire round of jumps unless the round is stopped and restarted. No competitor is allowed, to use a longer inrun, than decided by the Jury.

If the so-called wind/gate compensation system is in place the Jury may change the length of the in-run even during a competition round in order to approach the principles of fairness and safety. Such a decision must be based

on an unanimous decision of the Jury. The wind and gate compensation factor will be included in the total score.

A trainer/coach is entitled to reduce the length of in-run for his respective athlete. This has to be announced within the red phase of the starting procedure of the athlete concerned (does only apply for WC competitions). In such a case, the gate compensation factor is only calculated, if the athlete jumps at least 95 % of the HS distance.

- 525.1.3 The jumper is not allowed to use ski poles or any other kind of assistance. Nor is the jumper allowed to obtain outside assistance. Competitors who violate this rule will be disqualified.
- 525.1.4 When the hill is clear and the officials are ready, the chief of competition or authorized assistant shall give the start signal from the Judges tower for each competitor. No more than one signal should be used to initiate the exact time of the start control.
- 525.1.5 The start signal shall be determined by a green light displayed on the traffic light. If such a starting device is not available, the jumper can be signalled that the hill is clear by the waving of a flag by a control official located on the takeoff platform.
- 525.1.6 The jumper must have completely finished the jump before the next starting signal may be given.
- 525.1.7 It is the responsibility of the chief of competition to coordinate communication among all officials. This to include, the chief of hill, his various assistants at the takeoff, on the outrun, at the wind-measuring devices that the hill is clear, that all officials are ready, and that weather (wind) conditions are fair.
- 525.1.8 The starter shall report to the chief of competition the number of the upcoming jumper and the competitor's readiness to start.
- 525.1.9 It is the competitor's responsibility to be ready at the start when the starting number is called. The Jumper has according to the respective mode of the start time installation (10 seconds in case of three phase mode and 10 – 15 seconds in case of two-phase mode) to leave the start after the start signal has been given. If the jumper has not left the start gate by the end of the start time, the hill will automatically be closed (see art. 514.1.7.1, 514.1.7.2).
- 525.1.10 During the starting procedure the jumper must have the opportunity to clearly observe the automatic countdown display (e.g. a programmable digital clock) (see art. above).
- 525.1.11 The jumper has to start within the start time. If the start signal is interrupted during the competitor's starting period for any reason, for example unstable weather conditions, the starting process will begin again.
- 525.1.12 The jumper must not start before the official starting signal or intentionally delay readiness to receive signals from a third person. Feigning problems with skis, bindings, equipment, or clothing is inexcusable. Both types of actions will as a rule cause disqualification.

525.1.13 A competitor hindered by „force majeure“ who arrives late at the start may appeal to the Jury. After considering all the facts reported, the Jury may allow the competitor to participate in the remaining part of the competition out of starting order.

525.1.14 *Repetition of a Jump*

A competitor hindered or interfered with during the jump by an error on the part of an official, an animal, spectators or any other „force majeure“ may appeal to the Jury. After considering the facts reported, the Jury shall either allow or reject a repeat of the jump. In case of one of the above mentioned reasons, the Jury is entitled to allow repetition of the jump from their own point of view.

525.1.15 If combined ski jumping is carried out together with special ski jumping, the combined competitors should be drawn in a separate group. The combined competitors can be divided into subgroups.

525.1.16 If possible, style points shall be displayed after each competitor's jump (open scoring). An acoustic announcement concerning style points awarded is not permitted.

525.1.17 *95 % Rule*

A jumper, who has reached 95 % of the maximum length of the longest jump but has a fall, has the right to participate in the next round in addition to the qualified jumper (if the wind/gate compensation is used, the compensated distance is the basis).

**525.2 Cross-Country**

525.2.1 *Gundersen Method / Compact Format*

For the Gundersen method the winner of the jumping competition starts first, the second ranked starts next, etc. The start interval is the result of the converted point differences into time differences. The start times are rounded to full seconds.

**For the Compact format the winner of the jumping competition starts first the second ranked starts next, etc. according the fixed start intervals.**

525.2.2 *Mass Start*

Start positions will be determined by draw and/or an actual FIS Cup ranking list (see art 523.2.2).

525.2.2.1 At WSC and WCNC or other FIS Cup competitions the start positions will be determined according the actual World Cup or other Cup standings.

525.2.3 *Wave Start*

The Jury is responsible to make the decision about the "Wave Start" and appropriate start time within the start list. The competitors start in groups in 10 sec. interval. The decision for these groups will be made according to the length of the course and the venue. Competitors who have been lapped or stay just before must be pulled from the race only for OWG, WSC, WCNC and GP. For the final result, the removed athlete(s) will be ranked (no time) and



get their corresponding cup points at the place when they were removed. Special regulation Individual Gundersen see art. 540.3.

#### 525.2.4 **Responsibilities of Officials and Others**

525.2.4.1 *If required, the Jury will issue special regulations for officials, media and service people and any other non-competitors, to ensure order on the course, in the stadium and in the team preparation area before, during and after the competition.*

For order and control on the courses the following principles apply:

- from 5 minutes before the start until the time the course closers have passed, all officials, coaches, non-competitors and other accredited persons, are no longer permitted to ski on the course. During the competition, these persons must take fixed locations beside the course and must stand without skis on.
- while giving intermediate times and information to competitors, officials, coaches and others are not allowed to run more than 30 m beside the competitors.
- while doing this work officials and others have to ensure not to obstruct competitors.
- while giving refreshments to the competitors the coaches must ensure not to obstruct competitors.

525.2.5 Wax testing and warming up on the ski competition course must always be done in the competition course direction. Anyone testing skis on the competition course must consider the safety of others on the course and the course preparation. Electronic timing devices used for testing skis will not be allowed on the course during the competition or official training.

525.2.5.1 In order to obtain clean TV coverage and for safety reasons parts of the competition course may be closed for all but the competitors taking part in the competition. The Jury can allow ski testing and warming up by competitors on parts of the competition course before and during the competition. Athletes and service personnel, wearing special bibs may be allowed to ski on these parts of the competition course.

525.2.5.2 A ski glide testing area with testing tracks for all participating teams must be located close to the stadium. It should be close to the team wax cabins and warm-up track. The testing tracks must be prepared to the same standard as the competition course.

525.2.5.3 Warm up courses should be prepared as close as possible to the stadium.

#### 525.2.6 *Schedule Postponement*

With difficult weather conditions the Jury may postpone the competition. The decision by the Jury must be made not later than 30 minutes before regular starting time.

- 525.2.7      *Responsibilities of the competitors***
- 525.2.7.1      In all training and competition situations the athlete must act with due care taking into account the course conditions, visibility and competitor congestion.
- 525.2.7.2      In all training and competition situations the athletes must always ski in the competition course direction.
- 525.2.7.3      Competitors must follow the instructions (course opening times, wearing bibs, training, ski testing, etc.) issued by the Jury or OC in order to ensure order on the course, in the stadium and in the team preparation area before, during and after the competition.
- 525.2.7.4      The competitor is responsible for arriving at the start and starting at the correct time.
- 525.2.7.5      If transponders or GPS are used it is mandatory for the competitors to wear these equipment.
- 525.2.8      Competitors must follow the marked course from start to finish and must pass all controllers.
- 525.2.8.1      If a competitor skis on a wrong section or leaves the marked course, he should return to the point where they made the error. In order to do so, the competitor may have to ski against the correct ski direction and shall be totally responsible for ensuring that they do not obstruct or endanger other competitors.
- 525.2.9      They have to cover the whole distance on their skis using only their own means of propulsion. Help from pacemakers or pushing is not allowed.
- 525.2.10      In all competitions obstruction is not allowed. This behavior is defined as deliberately impeding, blocking, charging or pushing any competitor with any part of the body or ski equipment.
- 525.2.11      *Equipment exchange***
- 525.2.11.1      In all competitions pole exchange is only allowed in the case that a pole is broken or damaged.
- 525.2.11.2      Skis may be changed only if:  
  
The skis or bindings are broken or damaged. The equipment failure must be proven to the Jury after the competition.  
In the case of a ski exchange, the competitor must do it outside the track without help from any other people.
- 525.2.12      Waxing, scraping or cleaning of the competitor's skis during the competition is forbidden. It is not allowed to place branches, tools or materials on or adjacent to the groomed course.
- 525.2.13      *Position for a Competitor at the Start*  
  
The competitor must have his feet in front of the start line and remain stationary. The poles remain stationary and should be placed behind the starting line.

- 525.2.14 *Early Start for a Competitor*  
Each competitor is responsible himself to start at the right starting time. A competitor who starts too early must come back and pass through the starting line again. In this case, his starting time will be the time on the start list. Competitors who do not re-cross the starting line after an early start must be disqualified. To cross the marked starting line with the tip of the first shoe marks the beginning of the race. In order to get a clear presentation of evidence, adequate technical equipment must be installed in the starting area to cover the start procedure (art. 514.2.1).
- 525.2.15 *Late Start for a Competitor*  
A competitor who starts late must not interfere with the start of other competitors.
- 525.2.16 *Overtaking*  
During an individual- or team competition a competitor who is being overtaken must give way on the first demand. This applies in free technique courses even when the skier being overtaken may have to restrict his skating action. For all competitions, when overtaking occurs, competitors must not cause any obstruction (art. 525.2.10). The responsibility for a correct passing without obstruction is on the overtaking skier. The overtaking skier must have his/her skis in front of the skis of the overtaken skier before skiing his/her best line.
- 525.2.16.1 *Marked Corridors*  
In sections with marked corridors (e.g. finish zone) the competitors should choose a corridor. A competitor is allowed to leave the chosen corridor as long as art. 525.2.10 is upheld.
- 525.2.17 *Team Competitions Exchange*  
In a team event, the exchange is achieved by the arriving competitor, with a tap of the hand on any part of the next competitor's body while both competitors are in the relay exchange zone. If the relay hand-over occurs before or after (outside) the exchange zone, it will be considered as a false start and the procedure must be repeated within the exchange zone. Relay teams who have made a false start and do not return to the start again correctly must be disqualified. The next competitor may only enter the relay exchange zone when summoned. Any method of pushing the starting competitor is forbidden.
- 525.2.18  
The competitor is ranked if all the parts of his body have crossed the finish line without any outside help.
- 525.2.19 *Did Not Finish*  
If competitors abandon the competition before the finish, they must inform the first official they meet and they are responsible for returning the transponders and the start bib as soon as possible.
- 525.2.20  
The competitors must comply with the instructions of competition officials.

525.2.21 The competitor must comply with all aspects of the medical code (see art. 221).

525.2.22 Communication devices that support wireless communication between coaches and athletes or between athletes are not allowed during competition.

## **526 Bibs**

526.1 It is mandatory for the competitor to wear his start number during the official training (Ski Jumping and Cross-Country) and competition at OWG, WSC and WCNC. **Reserve or Blanko bibs with correct numbers (can be written) from the LOC is possible to use in such cases. Athlete must however pay a fine of CHF 500.--.**

526.2 For JWSC, COCNC and international Nordic Combined competitions it is mandatory for the competitor to wear his start number during all official jumping rounds (training and competition). Competitors who violate this ruling will be disqualified.

526.3 The start numbers must be legible from the back and the front. They must not hinder the competitor in any way. The size and the shape are described in the rules for competition equipment. It is not permitted to change the size, the shape and the method of attachment of the start number.

### **526.4 Cross-Country**

For OWG, WSC, JWSC and WCNC all start numbers used in all competition formats must also have numbers on both sides of the bib.

### **526.5 Leg Bibs**

At OWG, WSC, JWSC, WCNC and COCNC for all Individual competitions and the last competitor of the Team Competitions it is required to affix bibs to the competitor's leg that is closest to the finish line camera.

### **526.6 Team Competitions**

For each group, the team start numbers will be a different colour (same for both Ski Jumping and Cross-Country). For OWG, WSC, JWSC, WCNC and COCNC competitions they will be:

- 1<sup>st</sup> group = red start numbers
- 2<sup>nd</sup> group = green start numbers
- 3<sup>rd</sup> group = yellow start numbers
- 4<sup>th</sup> group = blue start numbers.

## **527 Calculating and Announcement of Results**

### **527.1 Start and Result Lists**

The following elements provide the basic format information for all lists:

- Name of the competition
- Date and place of competition

- Name of the hill and reference to its K-point and Hill Size (HS) or
- Name of course and reference to technical parameters
- HD, MC, TC, length of rounds
- Names and country of each Jumping Judge
- Names and country of each Jury member
- Information on the current weather (snow conditions, temperature, wind, etc.)
- Number of entered, started, finished, not finished and disqualified competitors
- Additional for each competitor
- Rank
- Bib number
- Last and first name, nation and/or club
- For each jump, the following information shall be recorded separately:
  - Distance jumped, inrun velocity, distance points
  - Style points
  - Collective points per round and
    - on the end of the line the total points or
  - Cross-Country time and rank
  - Calculated points after Cross-Country race (Mass start)

## **527.2 Ski Jumping**

### *527.2.1 Format for Trainings Lists*

For the official training results, in addition to the general points listed above, the following elements must be listed:  
inrun velocity/rank, distance jumped/rank, starting gate for each round

### *527.2.2 Instructions for the Start Lists*

See art. 527

### *527.2.3 Final Result Lists*

See art. 527

#### *527.2.3.1 Style Points*

Scoring starts with the scores of five Jumping Judges, and then the highest and lowest scores are eliminated. The three remaining scores are added. The sum of these scores is the total style points for a jump. The guidelines for the recording of the Jumping Judges note are given with in the ICR book III Ski Jumping, art. 431.

#### *527.2.3.2 Distance Points*

The points scored for the distances jumped are calculated on basis of the jumping hill. The point for one m is based on a points table determined on the K point of the hill.

K-Point Distance	Meter Value
20 – 24 m	4,8 pts./m
25 – 29 m	4,4 pts./m
30 – 34 m	4,0 pts./m
35 – 39 m	3,6 pts./m
40 – 49 m	3,2 pts./m
50 – 59 m	2,8 pts./m
60 – 69 m	2,4 pts./m
70 – 79 m	2,2 pts./m
80 – 99 m	2,0 pts./m
100 m and larger	1,8 pts./m
170 m and larger	0,6 pts./m

The K-point of the jumping hill acts as the table point; consequently, the K-point distance equals 60 distance points. After the m value of the hill has been determined, the distance difference of the measured lengths for jumps must be calculated. Distances shorter than the K-point are calculated by multiplying the m value by the length difference and subtracting this number from 60. By contrast, distances longer than the K-point are calculated by multiplying the m value by the length difference and adding this number to 60.

#### 527.2.3.3 *Collective Point Score*

This score is calculated by adding the style points and the distance points together. If the total of the style and distance points results in a negative sum, the minimum score is zero (no negative points).

#### 527.2.3.4 *Total Point Score*

This score is calculated by adding together the collective point scores from the competitive jumping rounds. The jumper with the highest total point score is the winner.

#### 527.2.3.5 *Identical Scores*

When two or more jumpers have identical scores, a tie is declared, and the jumpers are awarded the same place. The following position(s) shall be displaced (eliminated) in accordance with the number of tied places. In the final result list, ties' shall be listed in reverse order of the jumper's start number (the higher start number first).

### 527.3 **Announcement of the Jumping Results (Intermediate result)**

An unofficial results list will be posted immediately after the competition. The chief of calculations and the competition secretary examine and compare the unofficial results list with the original recording lists. The competition secretary then presents the final list for approval to the Jury. If the Jury has not received any protests, the results list will be published as the intermediate results after the protest time. The protest time as a rule is 15 minutes after the end of the competition. Team captains' meeting can decide on a shorter protest time.

### 527.3.1 *Style Judges Deduction Point List*

At OWG, WSC, WCNC and COCNC for each round of jumps an additional list concerning the style point deductions must be made.

## 527.4 **Cross-Country**

### 527.4.1 *Cross-Country Calculation Table*

The points or time differences between the competitors and to the winner of the Jumping competition or Cross-Country competition will be calculated for establishing the result difference between the competitors, **except Compact format with fixed start intervals**. This calculation based on the Nordic Combined table. The value of either time or points must be mathematically rounded depending on the competition format.

According to the length of the race course the following tables will be used.

For the calculation a six decimal point place is used:

5 km <b>to 15 km</b> course:	1 min =	15 points
2 x 7.5 km course:	1 min =	45 points
2 x 4.5 km course:	1 min =	45 points
2 x 6 km course:	1 min =	45 points
4 x 5 km course:	1 min =	60 points
5 km, 2.5 km, 2.5 km, 5 km course:	1 min =	60 points

Conversion tables by deviating distances are to be specified in sole responsibility of the national Ski Federations.

### 527.4.2 *Free Technique*

Free technique includes all Cross-Country skiing techniques.

## 527.5 **Final Result List**

After finishing of a Nordic Combined competition the TD and the Chief of Competition must sign the Official result list to confirm the correctness of the result.

All official results must also be electronically transmitted to FIS in XML format.

## 528 **Competition Formats**

OWG, WSC, JWSC, WCNC and COCNC

### 528.1 **Olympic Winter Games (OWG)**

Men:

Individual Gundersen	LH 10 km	
Individual Gundersen	NH 10 km	
Team-Sprint	NH 2x7,5 km	=> 5x1.5 km each

### 528.2 **World Ski Championships (WSC)**

Men:

Individual <b>competition</b>	LH
Individual <b>competition</b>	NH
Team/Team-Sprint	<b>NH or LH</b>

Women:  
 Individual **competition** NH  
 Individual **competition** NH

Men/Women:  
 Mixed Team NH 5.0 km, 2.5 km, 2.5 km, 5.0 km

**528.3 Junior World Ski Championships (JWSC)**

Men:  
 Individual Gundersen NH 10 km  
 Team-Sprint NH 2x7,5 km => 5x1.5 km each

Women:  
 Individual Gundersen NH 5 km  
 Team-Sprint NH 2x4,5 km => 3x1.5 km each

Men/Women:  
 Mixed Team NH 5.0 km, 2.5 km, 2.5 km, 5.0 km

**528.4 World Cup**

Men:  
 Individual **competition** NH, LH, **GH** or **FH**  
 Team/**Team-Sprint** NH or LH

Women:  
 Individual **competition** NH or LH  
 Team-Sprint NH 2x4,5 km => 3x1.5 km each

Men/Women:  
 Mixed Team-Sprint NH 2x6.0 km => 4x1.5 km each  
 Mixed Team NH 5.0 km, 2.5 km, 2.5 km, 5.0 km

**528.5 Continental Cup**

Men:  
 Individual **competition** NH or LH  
 Team NH or LH 4x5 km  
 Team-Sprint NH or LH 2x7.5 km => 5x1.5 km each

Women:  
 Individual **competition** NH  
 Team-Sprint NH 2x4,5 km => 3x1.5 km each

Men/Women:  
 Mixed Team NH 5.0 km, 2.5 km, 2.5 km, 5.0 km  
 Mixed Team-Sprint NH 2x6.0 km => 4x1.5 km each

Other formats are possible as long as the format is described in the respective Cup Rules.



## 530 **Sanctions and Protests**

The following articles 531, 532 and 533 have to be applied on the basis of

- art. 223 (sanctions),
- art. 224 (procedural guidelines) and
- art. 225 (appeals commission)

of the joint regulations for all competitions.

## 531 **Sanctions**

### 531.1 **General Conditions (see art. 223.1)**

#### 531.1.1 *Sanction may apply,*

- is in violation or non-observance of competition rules, or
- constitutes non-compliance with directives of the jury or individual members of the jury in accordance with 224.2 or
- constitutes unsportsmanlike behaviour is to consider whether the conduct was intentional or unintentional behaviour is present or whether the conduct arose from circumstances of an emergency.

#### 531.1.2 Sanctions may apply by the FIS Nordic Combined Committee

- against a TD or TD Assistant who has made irregular or unfair decisions and has personally misbehaved
- against a distance measurer who intentionally executes false or improper measurements and has personally misbehaved.

#### 531.1.3 ***Not Permitted to Start***

A competitor will not be permitted to start in any FIS International Ski competition who:

531.1.3.1 doesn't meet the eligibility requirements of art. 203 (FIS-license);

531.1.3.2 enters under or by false data

531.1.3.3 doesn't meet the age-group regulations (art. 521.1)

531.1.3.4 wears obscene names and/or symbols on clothing and equipment (art. 206.7) or behaves in an unsportsmanlike manner in the start area (art. 205.5)

531.1.3.5 violates the FIS rules in regard to equipment (art. 222) and commercial markings (art. 207)

531.1.3.6 refuses to undertake a FIS required medical examination (art. 221.2)

531.1.3.7 If a competitor has actually started in a competition and is later determined by the Jury to have been in violation of these rules the Jury must sanction the competitor.

531.1.3.8 Flour wax (art. 222.8): The control will be taken before and after the ski jumping and/or cross-country competitions.

## **531.2 Penalties**

A penalty will be assessed by the Jury where the competitor:

- 531.2.1 violates the rules governing advertising on equipment (art. 207.1)
- 531.2.2 alters the start number in a way which is not allowed (art. 526.3)
- 531.2.3 violates the rules of responsibility of competitor during the competition or demonstrates unsportsmanlike behaviour (art. 525.2.15)
- 531.2.4 takes skis to the official ceremonies (art. 207.1.1)

## **531.3 Disqualifications**

The jury must meet and decide if a competitor is to be disqualified (see art. 223.3.3) All relevant evidence must be carefully considered and the competitor must have the opportunity to defend himself (see art 224.7). A competitor will be considered to be disqualified if he

- 531.3.1 violates the rules of start procedure:

### *Jumping:*

Start Permission three- or two-phase mode (art. 514.1.7.1, 514.1.7.2)  
Any kind of assistance in the inrun to achieve higher speed (art. 525.1.3)  
Start signal from chief of competition or authorized assistant from the judge tower (art. 525.1.4)  
Start signal from a third person or intentionally delay of the start by the athlete (art. 525.1.12)

### *Cross-Country:*

Early start for a competitor (art. 525.2.14, 541.3)  
Team and Team Sprint Exchange (art. 525.2.17)

- 531.3.2 does not ski the entire marked course (art. 525.2.8)
- 531.3.2.1 Waxing, scraping or cleaning of the competitors's skis during the competition (art. 525.2.12)
- 531.3.3 violates the rules using transponder (art. 514.3, 525.2.7.5)
- 531.3.3.1 Wearing of the assigned bib during training and competition (art. 526.1, 526.2)
- 531.3.4 intentionally causes obstruction (art 525.2.10)
- 531.3.5 Use of Flour wax (art. 222.8).
- 531.3.6 After disqualification, a competitor's name will be shown on a revised result list indicating his status as DSQ and no times must be printed for this competitor.
- 531.3.7 **According to the rule 223.3.3 competitor shall only be disqualified if his mistake would result in an advantage for him with regard to the end result, unless the Rules state otherwise in an individual case.**

## **532 Protests**

- 532.1 Protests against the entry of a competitor must be delivered in writing to the competition secretary before the start of the competition.
- 532.2 Protests against the actions made by another competitor or an official during the competition must be made in writing to the competition secretary within 15 minutes after the completion of the competition.
- 532.2.1 At the OWG and WSC, a verbal protest must be submitted to any Jury Member within five (5) minutes.
- 532.3 Protests concerning incorrect calculations or result misprints shall be considered if sent by registered mail from the competitor's National Ski Association to the event organising association within one month of the date of the competition. If a mistake is proven, the correct results shall be republished and the awards redistributed if necessary.
- 532.4 The Jury must consider protests if they are made within the allowable time limit and a sum of CHF 100,-- or the equivalent in another valid currency has been deposited with the competition secretary. This deposit will be returned if the protest is upheld.
- 532.5 A protest may be withdrawn by the protesting party before the publication of a decision by the Jury. In this case, the money deposit must be returned.
- 532.6 Protests not submitted on time or submitted without the protest fee are not to be considered.
- 532.7 Distances measured manually by distance measurers and style scorings of jumping judges are subjective decisions (so called „statements of facts“) on real facts which are not repeatable and therefore, cannot be corrected. Therefore, protests against such subjective decisions aiming at a correction of the result are not allowed. This to include, protests concerning the start control procedure for ski jumping in situations of variable wind conditions.

## **533 Authorization**

The following are authorized to submit protests:

- the National Ski Associations
- Team Captains.

### **533.1 *Settlement of Protests by the Jury***

The Jury meets to deal with the protests at a predetermined place and time fixed and announced by it.

- 533.2 At the vote on the protest, only the Jury members are to be present. The TD chairs the proceedings. Minutes of the proceedings are to be kept and signed by all voting members of the Jury. The decision requires a majority of all voting members of the Jury, not just of those present. In case of a tie, the TD's vote is decisive.

## **534 Right of Appeal**

534.1 The Appeal

534.1.1 It can be made

- against all decisions of the Jury (see also ICR 224.11)
- against the official result lists. This appeal has to be directed exclusively against an obvious and proven calculation mistake.

534.1.2 Appeals must be submitted to the FIS by the NSA.

534.1.3 Deadlines

534.1.3.1 Appeals against the decisions of the Jury are to be submitted within 48 hours of the publication of the official results list.

534.1.3.2 The appeals against the official results are to be submitted within 30 days, including the day of the competition.

534.1.4 The decision concerning the appeals are taken by

- the Appeals Commission
- the FIS Court

534.2 Postponing Effect

The evidence submitted (protest, appeal) may not cause a postponement of the appeal.

534.3 Submission

All evidence must be in writing to be substantiated. Proof and evidence are to be included. Evidence submitted too late must be declined by the FIS (see 225.3). In order to file an appeal it must be accompanied with a deposit of CHF 500,-- which will be refunded if the appeal is upheld.

---

## 3<sup>rd</sup> Section

---

### Special Regulations for the Competition Formats

#### 540 Individual Gundersen Competition

##### 540.1 Competition Realisation

For the Gundersen Individual competition, the Jumping competition is held first with the Cross-Country race being the second event. To have start right for the Cross-Country race it is necessary for the competitor to have taken part in the competition round for Ski Jumping.

##### 540.2 Calculation

The calculation is based on the appropriate meter and point value according the art. 527.2.3.2 and 527.4.1. For the final result list the ranking must be fixed, if necessary with technical help. In case of two or more athletes arriving at the finish line with the identical times a decision is made by the use of the photo finish video or by finish referee (art. 514.2.5). In case when no visual differences between competitors can be determined with the assistance of the technical equipment, the same rank will be given in the final result. For cup competitions, the same points will be awarded.

##### 540.3 Special Regulations

To prevent too large start time differences, the Jury can decide upon the use of the „wave start“ (art. 525.2.3). According to the adjusted final result list it is possible that a tie in the final ranking may occur. The ranking of the competitors in this situation is based upon art. 527.2.3.5 When this occurs in a cup point event, the following rule applies: the tie competitors get the same points, with the following points value being eliminated.

#### 541 Individual Compact Competition

##### 541.1 Competition Realisation

541.1.1 Ski jumping: See ICR art 523.2, 525.1

541.1.2 Cross-Country: See ICR 525.2

541.1.3 For the Individual Compact competition, the Jumping competition is held first with the Cross-Country race being the second event. To have start right for the Cross-Country race it is necessary for the competitor to have taken part in the competition round for Ski Jumping. The start of the Cross-Country race is according to the fixed start intervals, (see art. 541.1.4)

##### 541.1.4 Fixed start intervals

Place	Start time	Place	Start time
1	00:00	15	00:48
2	00:06	16	00:50
3	00:12	17	00:52

<b>4</b>	00:17	<b>18</b>	00:54
<b>5</b>	00:22	<b>19</b>	00:56
<b>6</b>	00:26	<b>20</b>	00:58
<b>7</b>	00:30	<b>21</b>	01:00
<b>8</b>	00:33	<b>22 - 24</b>	01:05
<b>9</b>	00:36	<b>25 - 27</b>	01:10
<b>10</b>	00:38	<b>28 - 30</b>	01:15
<b>11</b>	00:40	<b>31 - 33</b>	01:20
<b>12</b>	00:42	<b>34 - 36</b>	01:25
<b>13</b>	00:44	<b>37 – all others</b>	01:30
<b>14</b>	00:46		

#### 541.1.5

#### Calculation

The calculation is based on the appropriate meter and point value according to the ICR art. 527.2.3.2 and 527.4.1.

For the final result list the ranking must be fixed, if necessary with technical help. In case of two or more athletes arriving at the finish line with the identical times a decision is made by the use of the photo finish video or by finish referee (art. 514.2.5).

In case when no visual differences between competitors can be determined with the assistance of the technical equipment, the same rank will be given in the final result. For cup competitions, the same points will be awarded.

## 542

### Individual Mass Start Competition

#### 542.1

#### Competition Realisation

The Individual Mass Start competition shall begin with a Mass start Cross-Country race (see art. 515.2.9, 523.2.2, 525.2.2, 527.1) followed by a one round Ski Jumping competition (see art. 527.1).

The jump competition will be judged as normal and includes Wind and Gate Compensation (when in use). The competition program must also include one trial round. The competition round is in reverse order of Cross-Country results, i.e. the winner of Cross-Country race gets the last start number for Ski Jumping.

At World Cup competitions the “to beat line” is also part of the hill marking.

#### 542.2

#### Calculation

##### 542.2.1

At Individual Mass Start competition, all athletes start at the same time and final results are determined by finish arrival order. The race winner will receive zero points, the rest of the field minus points, see art. 527.4.1 for the valid point table to be used.

By manual calculation from the table following rules are valid: at existing 2 values the first value applies, at three to seven values applies the middle value, is the number of the values more largely for four and uneven applies the left value apart from the center.

#### 542.3

#### Special Regulations

Recommended norms according to local situation

## Start

- Classic tracks before the start line, odd number, e.g. 5 or 7.
- Length of classic tracks after start line 30 to 50m.
- Distance between classic tracks minimum 1.2m.

or

Same standards but without classical tracks, except that the width of the corridors must be at least 2m, see also art. 515.2.4 and 515.2.9.

## Finish

- Number of corridors at least 3 (each 3 m)
- Width 9 m (minimum)

The start procedure for the Mass Start is:

- The starter must position himself at the start so that he can easily be heard by all competitors.
- At the latest, one minute before the start the competitors are commanded to „go to the start“ line. Then they are informed „30 seconds to start“. At this time, the starting clock will be blocked and out of view of the competitors, only the starter can see the clock. At his discretion, the starter gives an acoustical start signal or a shot (these commands should be given in English at all competitions).
- Competitors are not allowed to change tracks within marked corridors the first 30-50 m after the start line.
- Each competitor is responsible himself to start at the right starting time. The starting procedure must be recorded by a HD video camera. As a backup system for WC an additional transponder line has to be placed 1,5 m beyond the starting line. The reference time for the jury to check the start procedure is 1 second, which means all earlier starts must be checked. A competitor with a false start must be disqualified.

## **543** Team Gundersen Competition

### **543.1** Competition Realisation

The Team Gundersen format consists of a ski jumping event by one round and a relay Cross-Country competition. A team consists of four competitors who must participate in and complete both disciplines (Ski Jumping and Cross-Country).

### **543.2** Calculation

The calculation is based on the appropriate meter and point value according to the art. 527.2.3.2 and 527.4.1.

The start differences for the Cross-Country race will be calculated from the actual total points scored by each team from the Jump event.

For the final result list, the ranking must be fixed, if necessary with technical help. In case of two or more athletes arriving at the finish line with the identical times a decision is made by the use of the photo finish video or by finish referee (art. 514.2.5). In case when no visual differences between competitors can be

determined with the assistance of the technical equipment, the same rank will be given in the final result. For cup competitions, the same points will be awarded.

### **543.3 Special Regulation**

543.3.1 The selected 5 km course should use two times 2.5 km lap layout and meet the FIS homologation guidelines for this event.

543.2.2 A competitor who did not start in one round of the jump competition or was disqualified within a round will get zero points.

543.3.3 If the conditions so demand, the length of the inrun can be adjusted for each group, or a round of jumps for one specific group can be cancelled and re-started

## **544 Team-Sprint / Mixed Team-Sprint Competition**

### **544.1 Competition Realisation**

The Team-Sprint competition consists of team Ski Jumping and a 2x4.5 km (women) / 2x7.5 km (men) Cross-Country competition skied over short laps (each competitor must run 3x1.5 km / 5x1.5 km alternately).

The Mixed Team-Sprint competition consists of team Ski Jumping and a 2x6 km Cross-Country competition skied over short laps.

Start order Ski Jumping:	Women, men
Start order and distance Cross-Country:	Men, women (each competitor must run 4x1.5 km alternately)

A team consists of two competitors who must participate in and complete both disciplines (Ski Jumping and Cross-Country).

### **544.2 Calculation**

The calculation is based on the appropriate meter and point value according to the art. 527.2.3.2 and 527.4.1.

The start differences for the Cross-Country race will be calculated from the actual total points scored by each team from the Jump event.

For the final result list the ranking must be fixed, if necessary with technical help. In case of two or more athletes arriving at the finish line with the identical times a decision is made by the use of the photo finish video or by finish referee (art. 514.2.5). In case when no visual differences between competitors can be determined with the assistance of the technical equipment, the same rank will be given in the final result. For cup competitions, the same points will be awarded.

### **544.3 Special Regulation**

The start order for the jump event for the Team-Sprint competition will be based on the reverse order of the actual Nation's Cup ranking.

The start order for the jump event for the Mixed Team-Sprint competitions will be based on the reverse order of the sum of the actual World Cup Nations Standings (women and men).



- 544.3.1 A competitor who did not start in one round of the jump competition or was disqualified within a round will get zero points.
- 544.3.2 If the conditions so demand, the length of the inrun can be adjusted for each group, or a round of jumps for one specific group can be cancelled and restarted.
- 544.3.3 The 2x4.5 km, 2x6 km and 2x7.5 km competitions are to be run in laps of 1.500 m, with the competitors changing after each lap.
- 544.3.4 After both competitors have completed two laps, the elimination modus will start, whereby the team/s which is/are overlapped must abandon the competition and will be taken out by the jury. The Nation cup points will be awarded based on the actual standing of the team when it was taken out from the competition. Only one team per nation will get points.
- 544.3.5 The exchange area (see article 515.2.12) must be designed in such way, that all teams are assigned a preparation area box (approx. 1.5 m width and 2.5 - 3 m in length). Each box is fenced to the exchange zone with all assigned boxes situated within the prepared 30 to 40 m tag zone.  
The entrance to the exchange area is on the beginning of the boxes area. After each exchange the athlete must go back to the box through a corridor on the end of the boxes. The competitor who is not skiing must wait in his box or the area behind. He can be coached and make preparations to his skis.  
For each box, one service personal for ski preparation is allowed. The service personal stays in the box and the athlete has to bring the skis to the box. Only waxing equipment and the competitors racing-ski are allowed in the box (no extra equipment or skis).
- 544.3.6 At the WSC or JWSC it's only possible to start with one team per nation. Start numbers will be distributed in the reverse order of the nation's standing for WSC and in the reverse order of the last JWSC team result for JWSC.  
For WCNC or COCNC the number of participating teams will be according to the specific event rules.

## **545 Mixed-Team Competition**

### **545.1 Competition Realisation**

The Gundersen Mixed Team competition consists of a ski jump event by one round and a relay Cross-Country competition. A team consists of 4 competitors, two women and two men.

Start order Ski Jumping: Women, men, men and women.

Start order and distance Cross-Country: Men 5 km, women 2.5 km, women 2.5 km and men 5 km.

### **545.2 Calculation**

The calculation is based on the appropriate meter and point value according to the art. 527.2.3.2 and 527.4.1.

The start differences for the Cross-Country race will be calculated from the actual total points scored by each team from the Jump event.

For the final result list the ranking must be fixed, if necessary with technical help. In case of two or more athletes arriving at the finish line with the identical times a decision is made by the use of the photo finish video or by finish referee (art. 514.2.5). In case when no visual differences between competitors can be determined with the assistance of the technical equipment, the same rank will be given in the final result. For cup competitions, the same points will be awarded.

### **545.3 Special Regulation**

The starting order for Mixed Team competitions will be based on the reverse order of the sum of the actual World Cup Nations Standings (women and men).

For WSC or JWSC it's only possible to start with one team per Nation.

For all other FIS competitions the number of participating teams will be according to the specific event rules.

545.3.1 A competitor who did not start in the jumping competition (e.g. NPS) or was disqualified within a round will get zero points.

545.3.2 If the conditions so demand, the length of the inrun can be adjusted for each group, or a round of jumps for one specific group can be cancelled and re-started.

545.3.3 The course should use the 2.5 km lap layout and meet the FIS homologation guidelines for this event.

## **546 Summer Competitions**

Summer competitions in Nordic Combined are possible. For the Jumping event the same regulations as winter competitions are valid. The Cross-Country event can be held using different equipment (Roller Skis, Inline-Skates) or a running race. The invitation must state the competition format and race method.

## **547 Ski Flying Competition**

### **547.1 Competition Realisation**

For the Ski Flying Individual competition, the Jumping competition is held first with the Cross-Country race being the second event. To have start right for the Cross-Country race it is necessary for the competitor to have taken part in the competition round for Ski Jumping.

### **547.2 Entries**

Competitors in Ski Flying competitions can be entered only by their own National Ski Assosiation. The national association has full responsibility for competitors' actions.

### **547.3 Forejumpers/Test Ski Flying**

The organiser is responsible for the arrangement of twelve qualified forejumpers on each day. These jumpers may not be part of the official competition but must be entered by their National Ski Assosiation acc. ICR

Article 215. All of them must be capable to start from the starting point established by the Jury for the competition round. All forejumpers have to be at least 18 years old.

#### 547.4

##### Calculation

The calculation is based on the appropriate meter and point value according the art. 527.2.3.2 and 527.4.1. For the final result list the ranking must be fixed, if necessary with technical help. In case of two or more athletes arriving at the finish line with the identical times a decision is made by the use of the photo finish video or by finish referee (art. 514.2.5). In case when no visual differences between competitors can be determined with the assistance of the technical equipment, the same rank will be given in the final result. For cup competitions, the same points will be awarded.

#### 547.5

##### Special Regulations

To prevent too large start time differences, the Jury can decide upon the use of the „wave start“ (art. 525.2.3). According to the adjusted final result list it is possible that a tie in the final ranking may occur. The ranking of the competitors in this situation is based upon art. 527.2.3.5 When this occurs in a cup point event, the following rule applies: the tie competitors get the same points, with the following points value being eliminated. The so-called wind/gate system will be used based on 1,2 points/meter. Are allowed to start athletes from Top 30 Best Jumper Trophy 1.

---

## 4<sup>th</sup> Section

---

### Tables for Nordic Combined Cross-Country

#### 550 The Calculation of the Time Difference

550.1 In order to eliminate variations during the calculation of the time differences, the following principles are used:

550.2 The start differences for the Cross-Country event are based on the Ski Jumping result, this calculation is made according to either seconds per point or points per second.

550.3 The calculation made will be taken to the sixth decimal place. This will ensure that each point value calculation is factored with sufficient accuracy. The value of the seventh decimal point is ignored. Therefore, no rounding of the sixth decimal place value is to occur.

Example:

Default	=	45 points per minute
1 Minute per 45 points	=	60 seconds per 45 points
60 seconds: 45 points	=	1,333333...sec/pts.
For calculation	=	1,333333...sec/pts. (6 decimal place)

#### 550.4 Procedure for the Calculation of the Time Difference:

The calculated time differences will be rounded from 0,5 tenths to a full second:

0,499999 = 0  
0,5 = 1

#### 550.5 Calculation Example for Time Difference

Points difference	Seconds per point	Result	Time difference (sec)
50	1,333333	66,66665	67 (1:07)
22,3	1,333333	29,73333259	30 (0:30)
22,4	1,333333	29,333326	29 (0:29)

#### 550.6 Procedure for the Calculation for the Point Difference

The calculated time difference (unrounded) is the basis for the conversion of the point difference. The calculated point difference will be rounded from 0,05 to a full tenth of a point:

0,0499999 = 0,0  
0,05 = 0,1

550.7

**Calculation Example for Point Difference**

<b>Time difference (sec)</b>	<b>Seconds to points</b>	<b>Result</b>	<b>Point difference</b>
41,3 (0:41.3)	1,333333	30,975007	31,0
106,7 (1:46.7)	1,333333	80,025020	80,0
188,5 (3:08.5)	1,333333	141, 375035	141,4

551

**Table Value**

<b>Course (km)</b>	<b>Points/Minute</b>	<b>Seconds/Points</b>
Individual 5 to 15	15	4,0
2x4.5, 2x6, 2x7.5	45	1,333333
4x5 «5.0,2.5,2.5,5.0»	60	1,0

## Nordic Combined

Time Difference for 5 km to 15 km - Individual Competitions

15.0

Pts/Min = 4.000000 Sec/Pts

Punkte	0.0	0.1	0.2	0.3	0.4	0.5	0.6	0.7	0.8	0.9
0	00:00	00:00	00:01	00:01	00:02	00:02	00:02	00:03	00:03	00:04
1	00:04	00:04	00:05	00:05	00:06	00:06	00:06	00:07	00:07	00:08
2	00:08	00:08	00:09	00:09	00:10	00:10	00:10	00:11	00:11	00:12
3	00:12	00:12	00:13	00:13	00:14	00:14	00:14	00:15	00:15	00:16
4	00:16	00:16	00:17	00:17	00:18	00:18	00:18	00:19	00:19	00:20
5	00:20	00:20	00:21	00:21	00:22	00:22	00:22	00:23	00:23	00:24
6	00:24	00:24	00:25	00:25	00:26	00:26	00:26	00:27	00:27	00:28
7	00:28	00:28	00:29	00:29	00:30	00:30	00:30	00:31	00:31	00:32
8	00:32	00:32	00:33	00:33	00:34	00:34	00:34	00:35	00:35	00:36
9	00:36	00:36	00:37	00:37	00:38	00:38	00:38	00:39	00:39	00:40
10	00:40	00:40	00:41	00:41	00:42	00:42	00:42	00:43	00:43	00:44
11	00:44	00:44	00:45	00:45	00:46	00:46	00:46	00:47	00:47	00:48
12	00:48	00:48	00:49	00:49	00:50	00:50	00:50	00:51	00:51	00:52
13	00:52	00:52	00:53	00:53	00:54	00:54	00:54	00:55	00:55	00:56
14	00:56	00:56	00:57	00:57	00:58	00:58	00:58	00:59	00:59	01:00
15	01:00	01:00	01:01	01:01	01:02	01:02	01:02	01:03	01:03	01:04
16	01:04	01:04	01:05	01:05	01:06	01:06	01:06	01:07	01:07	01:08
17	01:08	01:08	01:09	01:09	01:10	01:10	01:10	01:11	01:11	01:12
18	01:12	01:12	01:13	01:13	01:14	01:14	01:14	01:15	01:15	01:16
19	01:16	01:16	01:17	01:17	01:18	01:18	01:18	01:19	01:19	01:20
20	01:20	01:20	01:21	01:21	01:22	01:22	01:22	01:23	01:23	01:24
21	01:24	01:24	01:25	01:25	01:26	01:26	01:26	01:27	01:27	01:28
22	01:28	01:28	01:29	01:29	01:30	01:30	01:30	01:31	01:31	01:32
23	01:32	01:32	01:33	01:33	01:34	01:34	01:34	01:35	01:35	01:36
24	01:36	01:36	01:37	01:37	01:38	01:38	01:38	01:39	01:39	01:40
25	01:40	01:40	01:41	01:41	01:42	01:42	01:42	01:43	01:43	01:44
26	01:44	01:44	01:45	01:45	01:46	01:46	01:46	01:47	01:47	01:48
27	01:48	01:48	01:49	01:49	01:50	01:50	01:50	01:51	01:51	01:52
28	01:52	01:52	01:53	01:53	01:54	01:54	01:54	01:55	01:55	01:56
29	01:56	01:56	01:57	01:57	01:58	01:58	01:58	01:59	01:59	02:00
30	02:00	02:00	02:01	02:01	02:02	02:02	02:02	02:03	02:03	02:04
31	02:04	02:04	02:05	02:05	02:06	02:06	02:06	02:07	02:07	02:08
32	02:08	02:08	02:09	02:09	02:10	02:10	02:10	02:11	02:11	02:12
33	02:12	02:12	02:13	02:13	02:14	02:14	02:14	02:15	02:15	02:16
34	02:16	02:16	02:17	02:17	02:18	02:18	02:18	02:19	02:19	02:20
35	02:20	02:20	02:21	02:21	02:22	02:22	02:22	02:23	02:23	02:24
36	02:24	02:24	02:25	02:25	02:26	02:26	02:26	02:27	02:27	02:28
37	02:28	02:28	02:29	02:29	02:30	02:30	02:30	02:31	02:31	02:32
38	02:32	02:32	02:33	02:33	02:34	02:34	02:34	02:35	02:35	02:36
39	02:36	02:36	02:37	02:37	02:38	02:38	02:38	02:39	02:39	02:40
40	02:40	02:40	02:41	02:41	02:42	02:42	02:42	02:43	02:43	02:44
41	02:44	02:44	02:45	02:45	02:46	02:46	02:46	02:47	02:47	02:48

## Nordic Combined

Time Difference for 5 km to 15 km - Individual Competitions

15.0

Pts/Min = 4.000000 Sec/Pts

Punkte	0.0	0.1	0.2	0.3	0.4	0.5	0.6	0.7	0.8	0.9
42	02:48	02:48	02:49	02:49	02:50	02:50	02:50	02:51	02:51	02:52
43	02:52	02:52	02:53	02:53	02:54	02:54	02:54	02:55	02:55	02:56
44	02:56	02:56	02:57	02:57	02:58	02:58	02:58	02:59	02:59	03:00
45	03:00	03:00	03:01	03:01	03:02	03:02	03:02	03:03	03:03	03:04
46	03:04	03:04	03:05	03:05	03:06	03:06	03:06	03:07	03:07	03:08
47	03:08	03:08	03:09	03:09	03:10	03:10	03:10	03:11	03:11	03:12
48	03:12	03:12	03:13	03:13	03:14	03:14	03:14	03:15	03:15	03:16
49	03:16	03:16	03:17	03:17	03:18	03:18	03:18	03:19	03:19	03:20
50	03:20	03:20	03:21	03:21	03:22	03:22	03:22	03:23	03:23	03:24
51	03:24	03:24	03:25	03:25	03:26	03:26	03:26	03:27	03:27	03:28
52	03:28	03:28	03:29	03:29	03:30	03:30	03:30	03:31	03:31	03:32
53	03:32	03:32	03:33	03:33	03:34	03:34	03:34	03:35	03:35	03:36
54	03:36	03:36	03:37	03:37	03:38	03:38	03:38	03:39	03:39	03:40
55	03:40	03:40	03:41	03:41	03:42	03:42	03:42	03:43	03:43	03:44
56	03:44	03:44	03:45	03:45	03:46	03:46	03:46	03:47	03:47	03:48
57	03:48	03:48	03:49	03:49	03:50	03:50	03:50	03:51	03:51	03:52
58	03:52	03:52	03:53	03:53	03:54	03:54	03:54	03:55	03:55	03:56
59	03:56	03:56	03:57	03:57	03:58	03:58	03:58	03:59	03:59	04:00
60	04:00	04:00	04:01	04:01	04:02	04:02	04:02	04:03	04:03	04:04
61	04:04	04:04	04:05	04:05	04:06	04:06	04:06	04:07	04:07	04:08
62	04:08	04:08	04:09	04:09	04:10	04:10	04:10	04:11	04:11	04:12
63	04:12	04:12	04:13	04:13	04:14	04:14	04:14	04:15	04:15	04:16
64	04:16	04:16	04:17	04:17	04:18	04:18	04:18	04:19	04:19	04:20
65	04:20	04:20	04:21	04:21	04:22	04:22	04:22	04:23	04:23	04:24
66	04:24	04:24	04:25	04:25	04:26	04:26	04:26	04:27	04:27	04:28
67	04:28	04:28	04:29	04:29	04:30	04:30	04:30	04:31	04:31	04:32
68	04:32	04:32	04:33	04:33	04:34	04:34	04:34	04:35	04:35	04:36
69	04:36	04:36	04:37	04:37	04:38	04:38	04:38	04:39	04:39	04:40
70	04:40	04:40	04:41	04:41	04:42	04:42	04:42	04:43	04:43	04:44
71	04:44	04:44	04:45	04:45	04:46	04:46	04:46	04:47	04:47	04:48
72	04:48	04:48	04:49	04:49	04:50	04:50	04:50	04:51	04:51	04:52
73	04:52	04:52	04:53	04:53	04:54	04:54	04:54	04:55	04:55	04:56
74	04:56	04:56	04:57	04:57	04:58	04:58	04:58	04:59	04:59	05:00
75	05:00	05:00	05:01	05:01	05:02	05:02	05:02	05:03	05:03	05:04
76	05:04	05:04	05:05	05:05	05:06	05:06	05:06	05:07	05:07	05:08
77	05:08	05:08	05:09	05:09	05:10	05:10	05:10	05:11	05:11	05:12
78	05:12	05:12	05:13	05:13	05:14	05:14	05:14	05:15	05:15	05:16
79	05:16	05:16	05:17	05:17	05:18	05:18	05:18	05:19	05:19	05:20
80	05:20	05:20	05:21	05:21	05:22	05:22	05:22	05:23	05:23	05:24
81	05:24	05:24	05:25	05:25	05:26	05:26	05:26	05:27	05:27	05:28
82	05:28	05:28	05:29	05:29	05:30	05:30	05:30	05:31	05:31	05:32
83	05:32	05:32	05:33	05:33	05:34	05:34	05:34	05:35	05:35	05:36

## Nordic Combined

Time Difference for 5 km to 15 km - Individual Competitions

15.0

Pts/Min = 4.000000 Sec/Pts

Punkte	0.0	0.1	0.2	0.3	0.4	0.5	0.6	0.7	0.8	0.9
84	05:36	05:36	05:37	05:37	05:38	05:38	05:38	05:39	05:39	05:40
85	05:40	05:40	05:41	05:41	05:42	05:42	05:42	05:43	05:43	05:44
86	05:44	05:44	05:45	05:45	05:46	05:46	05:46	05:47	05:47	05:48
87	05:48	05:48	05:49	05:49	05:50	05:50	05:50	05:51	05:51	05:52
88	05:52	05:52	05:53	05:53	05:54	05:54	05:54	05:55	05:55	05:56
89	05:56	05:56	05:57	05:57	05:58	05:58	05:58	05:59	05:59	06:00
90	06:00	06:00	06:01	06:01	06:02	06:02	06:02	06:03	06:03	06:04
91	06:04	06:04	06:05	06:05	06:06	06:06	06:06	06:07	06:07	06:08
92	06:08	06:08	06:09	06:09	06:10	06:10	06:10	06:11	06:11	06:12
93	06:12	06:12	06:13	06:13	06:14	06:14	06:14	06:15	06:15	06:16
94	06:16	06:16	06:17	06:17	06:18	06:18	06:18	06:19	06:19	06:20
95	06:20	06:20	06:21	06:21	06:22	06:22	06:22	06:23	06:23	06:24
96	06:24	06:24	06:25	06:25	06:26	06:26	06:26	06:27	06:27	06:28
97	06:28	06:28	06:29	06:29	06:30	06:30	06:30	06:31	06:31	06:32
98	06:32	06:32	06:33	06:33	06:34	06:34	06:34	06:35	06:35	06:36
99	06:36	06:36	06:37	06:37	06:38	06:38	06:38	06:39	06:39	06:40
100	06:40	06:40	06:41	06:41	06:42	06:42	06:42	06:43	06:43	06:44
101	06:44	06:44	06:45	06:45	06:46	06:46	06:46	06:47	06:47	06:48
102	06:48	06:48	06:49	06:49	06:50	06:50	06:50	06:51	06:51	06:52
103	06:52	06:52	06:53	06:53	06:54	06:54	06:54	06:55	06:55	06:56
104	06:56	06:56	06:57	06:57	06:58	06:58	06:58	06:59	06:59	07:00
105	07:00	07:00	07:01	07:01	07:02	07:02	07:02	07:03	07:03	07:04
106	07:04	07:04	07:05	07:05	07:06	07:06	07:06	07:07	07:07	07:08
107	07:08	07:08	07:09	07:09	07:10	07:10	07:10	07:11	07:11	07:12
108	07:12	07:12	07:13	07:13	07:14	07:14	07:14	07:15	07:15	07:16
109	07:16	07:16	07:17	07:17	07:18	07:18	07:18	07:19	07:19	07:20
110	07:20	07:20	07:21	07:21	07:22	07:22	07:22	07:23	07:23	07:24
111	07:24	07:24	07:25	07:25	07:26	07:26	07:26	07:27	07:27	07:28
112	07:28	07:28	07:29	07:29	07:30	07:30	07:30	07:31	07:31	07:32
113	07:32	07:32	07:33	07:33	07:34	07:34	07:34	07:35	07:35	07:36
114	07:36	07:36	07:37	07:37	07:38	07:38	07:38	07:39	07:39	07:40
115	07:40	07:40	07:41	07:41	07:42	07:42	07:42	07:43	07:43	07:44
116	07:44	07:44	07:45	07:45	07:46	07:46	07:46	07:47	07:47	07:48
117	07:48	07:48	07:49	07:49	07:50	07:50	07:50	07:51	07:51	07:52
118	07:52	07:52	07:53	07:53	07:54	07:54	07:54	07:55	07:55	07:56
119	07:56	07:56	07:57	07:57	07:58	07:58	07:58	07:59	07:59	08:00
120	08:00	08:00	08:01	08:01	08:02	08:02	08:02	08:03	08:03	08:04
121	08:04	08:04	08:05	08:05	08:06	08:06	08:06	08:07	08:07	08:08
122	08:08	08:08	08:09	08:09	08:10	08:10	08:10	08:11	08:11	08:12
123	08:12	08:12	08:13	08:13	08:14	08:14	08:14	08:15	08:15	08:16
124	08:16	08:16	08:17	08:17	08:18	08:18	08:18	08:19	08:19	08:20
125	08:20	08:20	08:21	08:21	08:22	08:22	08:22	08:23	08:23	08:24



## Nordic Combined

Time Difference for 5 km to 15 km - Individual Competitions

15.0

Pts/Min = 4.000000 Sec/Pts

Punkte	0.0	0.1	0.2	0.3	0.4	0.5	0.6	0.7	0.8	0.9
126	08:24	08:24	08:25	08:25	08:26	08:26	08:26	08:27	08:27	08:28
127	08:28	08:28	08:29	08:29	08:30	08:30	08:30	08:31	08:31	08:32
128	08:32	08:32	08:33	08:33	08:34	08:34	08:34	08:35	08:35	08:36
129	08:36	08:36	08:37	08:37	08:38	08:38	08:38	08:39	08:39	08:40
130	08:40	08:40	08:41	08:41	08:42	08:42	08:42	08:43	08:43	08:44
131	08:44	08:44	08:45	08:45	08:46	08:46	08:46	08:47	08:47	08:48
132	08:48	08:48	08:49	08:49	08:50	08:50	08:50	08:51	08:51	08:52
133	08:52	08:52	08:53	08:53	08:54	08:54	08:54	08:55	08:55	08:56
134	08:56	08:56	08:57	08:57	08:58	08:58	08:58	08:59	08:59	09:00
135	09:00	09:00	09:01	09:01	09:02	09:02	09:02	09:03	09:03	09:04
136	09:04	09:04	09:05	09:05	09:06	09:06	09:06	09:07	09:07	09:08
137	09:08	09:08	09:09	09:09	09:10	09:10	09:10	09:11	09:11	09:12
138	09:12	09:12	09:13	09:13	09:14	09:14	09:14	09:15	09:15	09:16
139	09:16	09:16	09:17	09:17	09:18	09:18	09:18	09:19	09:19	09:20
140	09:20	09:20	09:21	09:21	09:22	09:22	09:22	09:23	09:23	09:24
141	09:24	09:24	09:25	09:25	09:26	09:26	09:26	09:27	09:27	09:28
142	09:28	09:28	09:29	09:29	09:30	09:30	09:30	09:31	09:31	09:32
143	09:32	09:32	09:33	09:33	09:34	09:34	09:34	09:35	09:35	09:36
144	09:36	09:36	09:37	09:37	09:38	09:38	09:38	09:39	09:39	09:40
145	09:40	09:40	09:41	09:41	09:42	09:42	09:42	09:43	09:43	09:44
146	09:44	09:44	09:45	09:45	09:46	09:46	09:46	09:47	09:47	09:48
147	09:48	09:48	09:49	09:49	09:50	09:50	09:50	09:51	09:51	09:52
148	09:52	09:52	09:53	09:53	09:54	09:54	09:54	09:55	09:55	09:56
149	09:56	09:56	09:57	09:57	09:58	09:58	09:58	09:59	09:59	10:00
150	10:00	10:00	10:01	10:01	10:02	10:02	10:02	10:03	10:03	10:04

## Nordic Combined

Time Difference for **Team Sprint / Mixed Team Sprint Competitions**

45.0

Pts/Min = 1.333333 Sec/Pts

Punkte	0.0	0.1	0.2	0.3	0.4	0.5	0.6	0.7	0.8	0.9
0	00:00	00:00	00:00	00:00	00:01	00:01	00:01	00:01	00:01	00:01
1	00:01	00:01	00:02	00:02	00:02	00:02	00:02	00:02	00:02	00:03
2	00:03	00:03	00:03	00:03	00:03	00:03	00:03	00:04	00:04	00:04
3	00:04	00:04	00:04	00:04	00:05	00:05	00:05	00:05	00:05	00:05
4	00:05	00:05	00:06	00:06	00:06	00:06	00:06	00:06	00:06	00:07
5	00:07	00:07	00:07	00:07	00:07	00:07	00:07	00:08	00:08	00:08
6	00:08	00:08	00:08	00:08	00:09	00:09	00:09	00:09	00:09	00:09
7	00:09	00:09	00:10	00:10	00:10	00:10	00:10	00:10	00:10	00:11
8	00:11	00:11	00:11	00:11	00:11	00:11	00:11	00:12	00:12	00:12
9	00:12	00:12	00:12	00:12	00:13	00:13	00:13	00:13	00:13	00:13
10	00:13	00:13	00:14	00:14	00:14	00:14	00:14	00:14	00:14	00:15
11	00:15	00:15	00:15	00:15	00:15	00:15	00:15	00:16	00:16	00:16
12	00:16	00:16	00:16	00:16	00:17	00:17	00:17	00:17	00:17	00:17
13	00:17	00:17	00:18	00:18	00:18	00:18	00:18	00:18	00:18	00:19
14	00:19	00:19	00:19	00:19	00:19	00:19	00:19	00:20	00:20	00:20
15	00:20	00:20	00:20	00:20	00:21	00:21	00:21	00:21	00:21	00:21
16	00:21	00:21	00:22	00:22	00:22	00:22	00:22	00:22	00:22	00:23
17	00:23	00:23	00:23	00:23	00:23	00:23	00:23	00:24	00:24	00:24
18	00:24	00:24	00:24	00:24	00:25	00:25	00:25	00:25	00:25	00:25
19	00:25	00:25	00:26	00:26	00:26	00:26	00:26	00:26	00:26	00:27
20	00:27	00:27	00:27	00:27	00:27	00:27	00:27	00:28	00:28	00:28
21	00:28	00:28	00:28	00:28	00:29	00:29	00:29	00:29	00:29	00:29
22	00:29	00:29	00:30	00:30	00:30	00:30	00:30	00:30	00:30	00:31
23	00:31	00:31	00:31	00:31	00:31	00:31	00:31	00:32	00:32	00:32
24	00:32	00:32	00:32	00:32	00:33	00:33	00:33	00:33	00:33	00:33
25	00:33	00:33	00:34	00:34	00:34	00:34	00:34	00:34	00:34	00:35
26	00:35	00:35	00:35	00:35	00:35	00:35	00:35	00:36	00:36	00:36
27	00:36	00:36	00:36	00:36	00:37	00:37	00:37	00:37	00:37	00:37
28	00:37	00:37	00:38	00:38	00:38	00:38	00:38	00:38	00:38	00:39
29	00:39	00:39	00:39	00:39	00:39	00:39	00:39	00:40	00:40	00:40
30	00:40	00:40	00:40	00:40	00:41	00:41	00:41	00:41	00:41	00:41
31	00:41	00:41	00:42	00:42	00:42	00:42	00:42	00:42	00:42	00:43
32	00:43	00:43	00:43	00:43	00:43	00:43	00:43	00:44	00:44	00:44
33	00:44	00:44	00:44	00:44	00:45	00:45	00:45	00:45	00:45	00:45
34	00:45	00:45	00:46	00:46	00:46	00:46	00:46	00:46	00:46	00:47
35	00:47	00:47	00:47	00:47	00:47	00:47	00:47	00:48	00:48	00:48
36	00:48	00:48	00:48	00:48	00:49	00:49	00:49	00:49	00:49	00:49
37	00:49	00:49	00:50	00:50	00:50	00:50	00:50	00:50	00:50	00:51

## Nordic Combined

Time Difference for **Team Sprint / Mixed Team Sprint Competitions**

45.0

Pts/Min = 1.333333 Sec/Pts

Punkte	0.0	0.1	0.2	0.3	0.4	0.5	0.6	0.7	0.8	0.9
38	00:51	00:51	00:51	00:51	00:51	00:51	00:51	00:52	00:52	00:52
39	00:52	00:52	00:52	00:52	00:53	00:53	00:53	00:53	00:53	00:53
40	00:53	00:53	00:54	00:54	00:54	00:54	00:54	00:54	00:54	00:55
41	00:55	00:55	00:55	00:55	00:55	00:55	00:55	00:56	00:56	00:56
42	00:56	00:56	00:56	00:56	00:57	00:57	00:57	00:57	00:57	00:57
43	00:57	00:57	00:58	00:58	00:58	00:58	00:58	00:58	00:58	00:59
44	00:59	00:59	00:59	00:59	00:59	00:59	00:59	01:00	01:00	01:00
45	01:00	01:00	01:00	01:00	01:01	01:01	01:01	01:01	01:01	01:01
46	01:01	01:01	01:02	01:02	01:02	01:02	01:02	01:02	01:02	01:03
47	01:03	01:03	01:03	01:03	01:03	01:03	01:03	01:04	01:04	01:04
48	01:04	01:04	01:04	01:04	01:05	01:05	01:05	01:05	01:05	01:05
49	01:05	01:05	01:06	01:06	01:06	01:06	01:06	01:06	01:06	01:07
50	01:07	01:07	01:07	01:07	01:07	01:07	01:07	01:08	01:08	01:08
51	01:08	01:08	01:08	01:08	01:09	01:09	01:09	01:09	01:09	01:09
52	01:09	01:09	01:10	01:10	01:10	01:10	01:10	01:10	01:10	01:11
53	01:11	01:11	01:11	01:11	01:11	01:11	01:11	01:12	01:12	01:12
54	01:12	01:12	01:12	01:12	01:13	01:13	01:13	01:13	01:13	01:13
55	01:13	01:13	01:14	01:14	01:14	01:14	01:14	01:14	01:14	01:15
56	01:15	01:15	01:15	01:15	01:15	01:15	01:15	01:16	01:16	01:16
57	01:16	01:16	01:16	01:16	01:17	01:17	01:17	01:17	01:17	01:17
58	01:17	01:17	01:18	01:18	01:18	01:18	01:18	01:18	01:18	01:19
59	01:19	01:19	01:19	01:19	01:19	01:19	01:19	01:20	01:20	01:20
60	01:20	01:20	01:20	01:20	01:21	01:21	01:21	01:21	01:21	01:21
61	01:21	01:21	01:22	01:22	01:22	01:22	01:22	01:22	01:22	01:23
62	01:23	01:23	01:23	01:23	01:23	01:23	01:23	01:24	01:24	01:24
63	01:24	01:24	01:24	01:24	01:25	01:25	01:25	01:25	01:25	01:25
64	01:25	01:25	01:26	01:26	01:26	01:26	01:26	01:26	01:26	01:27
65	01:27	01:27	01:27	01:27	01:27	01:27	01:27	01:28	01:28	01:28
66	01:28	01:28	01:28	01:28	01:29	01:29	01:29	01:29	01:29	01:29
67	01:29	01:29	01:30	01:30	01:30	01:30	01:30	01:30	01:30	01:31
68	01:31	01:31	01:31	01:31	01:31	01:31	01:31	01:32	01:32	01:32
69	01:32	01:32	01:32	01:32	01:33	01:33	01:33	01:33	01:33	01:33
70	01:33	01:33	01:34	01:34	01:34	01:34	01:34	01:34	01:34	01:35
71	01:35	01:35	01:35	01:35	01:35	01:35	01:35	01:36	01:36	01:36
72	01:36	01:36	01:36	01:36	01:37	01:37	01:37	01:37	01:37	01:37
73	01:37	01:37	01:38	01:38	01:38	01:38	01:38	01:38	01:38	01:39
74	01:39	01:39	01:39	01:39	01:39	01:39	01:39	01:40	01:40	01:40
75	01:40	01:40	01:40	01:40	01:41	01:41	01:41	01:41	01:41	01:41

## Nordic Combined

Time Difference for **Team Sprint / Mixed Team Sprint Competitions**

45.0

Pts/Min = 1.333333 Sec/Pts

Punkte	0.0	0.1	0.2	0.3	0.4	0.5	0.6	0.7	0.8	0.9
76	01:41	01:41	01:42	01:42	01:42	01:42	01:42	01:42	01:42	01:43
77	01:43	01:43	01:43	01:43	01:43	01:43	01:43	01:44	01:44	01:44
78	01:44	01:44	01:44	01:44	01:45	01:45	01:45	01:45	01:45	01:45
79	01:45	01:45	01:46	01:46	01:46	01:46	01:46	01:46	01:46	01:47
80	01:47	01:47	01:47	01:47	01:47	01:47	01:47	01:48	01:48	01:48
81	01:48	01:48	01:48	01:48	01:49	01:49	01:49	01:49	01:49	01:49
82	01:49	01:49	01:50	01:50	01:50	01:50	01:50	01:50	01:50	01:51
83	01:51	01:51	01:51	01:51	01:51	01:51	01:51	01:52	01:52	01:52
84	01:52	01:52	01:52	01:52	01:53	01:53	01:53	01:53	01:53	01:53
85	01:53	01:53	01:54	01:54	01:54	01:54	01:54	01:54	01:54	01:55
86	01:55	01:55	01:55	01:55	01:55	01:55	01:55	01:56	01:56	01:56
87	01:56	01:56	01:56	01:56	01:57	01:57	01:57	01:57	01:57	01:57
88	01:57	01:57	01:58	01:58	01:58	01:58	01:58	01:58	01:58	01:59
89	01:59	01:59	01:59	01:59	01:59	01:59	01:59	02:00	02:00	02:00
90	02:00	02:00	02:00	02:00	02:01	02:01	02:01	02:01	02:01	02:01
91	02:01	02:01	02:02	02:02	02:02	02:02	02:02	02:02	02:02	02:03
92	02:03	02:03	02:03	02:03	02:03	02:03	02:03	02:04	02:04	02:04
93	02:04	02:04	02:04	02:04	02:05	02:05	02:05	02:05	02:05	02:05
94	02:05	02:05	02:06	02:06	02:06	02:06	02:06	02:06	02:06	02:07
95	02:07	02:07	02:07	02:07	02:07	02:07	02:07	02:08	02:08	02:08
96	02:08	02:08	02:08	02:08	02:09	02:09	02:09	02:09	02:09	02:09
97	02:09	02:09	02:10	02:10	02:10	02:10	02:10	02:10	02:10	02:11
98	02:11	02:11	02:11	02:11	02:11	02:11	02:11	02:12	02:12	02:12
99	02:12	02:12	02:12	02:12	02:13	02:13	02:13	02:13	02:13	02:13
100	02:13	02:13	02:14	02:14	02:14	02:14	02:14	02:14	02:14	02:15
101	02:15	02:15	02:15	02:15	02:15	02:15	02:15	02:16	02:16	02:16
102	02:16	02:16	02:16	02:16	02:17	02:17	02:17	02:17	02:17	02:17
103	02:17	02:17	02:18	02:18	02:18	02:18	02:18	02:18	02:18	02:19
104	02:19	02:19	02:19	02:19	02:19	02:19	02:19	02:20	02:20	02:20
105	02:20	02:20	02:20	02:20	02:21	02:21	02:21	02:21	02:21	02:21
106	02:21	02:21	02:22	02:22	02:22	02:22	02:22	02:22	02:22	02:23
107	02:23	02:23	02:23	02:23	02:23	02:23	02:23	02:24	02:24	02:24
108	02:24	02:24	02:24	02:24	02:25	02:25	02:25	02:25	02:25	02:25
109	02:25	02:25	02:26	02:26	02:26	02:26	02:26	02:26	02:26	02:27
110	02:27	02:27	02:27	02:27	02:27	02:27	02:27	02:28	02:28	02:28
111	02:28	02:28	02:28	02:28	02:29	02:29	02:29	02:29	02:29	02:29
112	02:29	02:29	02:30	02:30	02:30	02:30	02:30	02:30	02:30	02:31
113	02:31	02:31	02:31	02:31	02:31	02:31	02:31	02:32	02:32	02:32

## Nordic Combined

Time Difference for **Team Sprint / Mixed Team Sprint Competitions**

45.0

Pts/Min = 1.333333 Sec/Pts

Punkte	0.0	0.1	0.2	0.3	0.4	0.5	0.6	0.7	0.8	0.9
114	02:32	02:32	02:32	02:32	02:33	02:33	02:33	02:33	02:33	02:33
115	02:33	02:33	02:34	02:34	02:34	02:34	02:34	02:34	02:34	02:35
116	02:35	02:35	02:35	02:35	02:35	02:35	02:35	02:36	02:36	02:36
117	02:36	02:36	02:36	02:36	02:37	02:37	02:37	02:37	02:37	02:37
118	02:37	02:37	02:38	02:38	02:38	02:38	02:38	02:38	02:38	02:39
119	02:39	02:39	02:39	02:39	02:39	02:39	02:39	02:40	02:40	02:40
120	02:40	02:40	02:40	02:40	02:41	02:41	02:41	02:41	02:41	02:41
121	02:41	02:41	02:42	02:42	02:42	02:42	02:42	02:42	02:42	02:43
122	02:43	02:43	02:43	02:43	02:43	02:43	02:43	02:44	02:44	02:44
123	02:44	02:44	02:44	02:44	02:45	02:45	02:45	02:45	02:45	02:45
124	02:45	02:45	02:46	02:46	02:46	02:46	02:46	02:46	02:46	02:47
125	02:47	02:47	02:47	02:47	02:47	02:47	02:47	02:48	02:48	02:48
126	02:48	02:48	02:48	02:48	02:49	02:49	02:49	02:49	02:49	02:49
127	02:49	02:49	02:50	02:50	02:50	02:50	02:50	02:50	02:50	02:51
128	02:51	02:51	02:51	02:51	02:51	02:51	02:51	02:52	02:52	02:52
129	02:52	02:52	02:52	02:52	02:53	02:53	02:53	02:53	02:53	02:53
130	02:53	02:53	02:54	02:54	02:54	02:54	02:54	02:54	02:54	02:55
131	02:55	02:55	02:55	02:55	02:55	02:55	02:55	02:56	02:56	02:56
132	02:56	02:56	02:56	02:56	02:57	02:57	02:57	02:57	02:57	02:57
133	02:57	02:57	02:58	02:58	02:58	02:58	02:58	02:58	02:58	02:59
134	02:59	02:59	02:59	02:59	02:59	02:59	02:59	03:00	03:00	03:00
135	03:00	03:00	03:00	03:00	03:01	03:01	03:01	03:01	03:01	03:01
136	03:01	03:01	03:02	03:02	03:02	03:02	03:02	03:02	03:02	03:03
137	03:03	03:03	03:03	03:03	03:03	03:03	03:03	03:04	03:04	03:04
138	03:04	03:04	03:04	03:04	03:05	03:05	03:05	03:05	03:05	03:05
139	03:05	03:05	03:06	03:06	03:06	03:06	03:06	03:06	03:06	03:07
140	03:07	03:07	03:07	03:07	03:07	03:07	03:07	03:08	03:08	03:08
141	03:08	03:08	03:08	03:08	03:09	03:09	03:09	03:09	03:09	03:09
142	03:09	03:09	03:10	03:10	03:10	03:10	03:10	03:10	03:10	03:11
143	03:11	03:11	03:11	03:11	03:11	03:11	03:11	03:12	03:12	03:12
144	03:12	03:12	03:12	03:12	03:13	03:13	03:13	03:13	03:13	03:13
145	03:13	03:13	03:14	03:14	03:14	03:14	03:14	03:14	03:14	03:15
146	03:15	03:15	03:15	03:15	03:15	03:15	03:15	03:16	03:16	03:16
147	03:16	03:16	03:16	03:16	03:17	03:17	03:17	03:17	03:17	03:17
148	03:17	03:17	03:18	03:18	03:18	03:18	03:18	03:18	03:18	03:19
149	03:19	03:19	03:19	03:19	03:19	03:19	03:19	03:20	03:20	03:20
150	03:20	03:20	03:20	03:20	03:21	03:21	03:21	03:21	03:21	03:21
151	03:21	03:21	03:22	03:22	03:22	03:22	03:22	03:22	03:22	03:23

## Nordic Combined

Time Difference for **Team Sprint / Mixed Team Sprint Competitions**

**45.0**

Pts/Min = 1.333333 Sec/Pts

Punkte	0.0	0.1	0.2	0.3	0.4	0.5	0.6	0.7	0.8	0.9
152	03:23	03:23	03:23	03:23	03:23	03:23	03:23	03:24	03:24	03:24
153	03:24	03:24	03:24	03:24	03:25	03:25	03:25	03:25	03:25	03:25
154	03:25	03:25	03:26	03:26	03:26	03:26	03:26	03:26	03:26	03:27
155	03:27	03:27	03:27	03:27	03:27	03:27	03:27	03:28	03:28	03:28
156	03:28	03:28	03:28	03:28	03:29	03:29	03:29	03:29	03:29	03:29
157	03:29	03:29	03:30	03:30	03:30	03:30	03:30	03:30	03:30	03:31
158	03:31	03:31	03:31	03:31	03:31	03:31	03:31	03:32	03:32	03:32
159	03:32	03:32	03:32	03:32	03:33	03:33	03:33	03:33	03:33	03:33
160	03:33	03:33	03:34	03:34	03:34	03:34	03:34	03:34	03:34	03:35
161	03:35	03:35	03:35	03:35	03:35	03:35	03:35	03:36	03:36	03:36
162	03:36	03:36	03:36	03:36	03:37	03:37	03:37	03:37	03:37	03:37
163	03:37	03:37	03:38	03:38	03:38	03:38	03:38	03:38	03:38	03:39
164	03:39	03:39	03:39	03:39	03:39	03:39	03:39	03:40	03:40	03:40
165	03:40	03:40	03:40	03:40	03:41	03:41	03:41	03:41	03:41	03:41
166	03:41	03:41	03:42	03:42	03:42	03:42	03:42	03:42	03:42	03:43
167	03:43	03:43	03:43	03:43	03:43	03:43	03:43	03:44	03:44	03:44
168	03:44	03:44	03:44	03:44	03:45	03:45	03:45	03:45	03:45	03:45
169	03:45	03:45	03:46	03:46	03:46	03:46	03:46	03:46	03:46	03:47
170	03:47	03:47	03:47	03:47	03:47	03:47	03:47	03:48	03:48	03:48
171	03:48	03:48	03:48	03:48	03:49	03:49	03:49	03:49	03:49	03:49
172	03:49	03:49	03:50	03:50	03:50	03:50	03:50	03:50	03:50	03:51
173	03:51	03:51	03:51	03:51	03:51	03:51	03:51	03:52	03:52	03:52
174	03:52	03:52	03:52	03:52	03:53	03:53	03:53	03:53	03:53	03:53
175	03:53	03:53	03:54	03:54	03:54	03:54	03:54	03:54	03:54	03:55
176	03:55	03:55	03:55	03:55	03:55	03:55	03:55	03:56	03:56	03:56
177	03:56	03:56	03:56	03:56	03:57	03:57	03:57	03:57	03:57	03:57
178	03:57	03:57	03:58	03:58	03:58	03:58	03:58	03:58	03:58	03:59
179	03:59	03:59	03:59	03:59	03:59	03:59	03:59	04:00	04:00	04:00
180	04:00	04:00	04:00	04:00	04:01	04:01	04:01	04:01	04:01	04:01
181	04:01	04:01	04:02	04:02	04:02	04:02	04:02	04:02	04:02	04:03
182	04:03	04:03	04:03	04:03	04:03	04:03	04:03	04:04	04:04	04:04
183	04:04	04:04	04:04	04:04	04:05	04:05	04:05	04:05	04:05	04:05
184	04:05	04:05	04:06	04:06	04:06	04:06	04:06	04:06	04:06	04:07
185	04:07	04:07	04:07	04:07	04:07	04:07	04:07	04:08	04:08	04:08
186	04:08	04:08	04:08	04:08	04:09	04:09	04:09	04:09	04:09	04:09
187	04:09	04:09	04:10	04:10	04:10	04:10	04:10	04:10	04:10	04:11
188	04:11	04:11	04:11	04:11	04:11	04:11	04:11	04:12	04:12	04:12
189	04:12	04:12	04:12	04:12	04:13	04:13	04:13	04:13	04:13	04:13

## Nordic Combined

Time Difference for **Team Sprint / Mixed Team Sprint Competitions**

**45.0**

Pts/Min = 1.333333 Sec/Pts

Punkte	0.0	0.1	0.2	0.3	0.4	0.5	0.6	0.7	0.8	0.9
190	04:13	04:13	04:14	04:14	04:14	04:14	04:14	04:14	04:14	04:15
191	04:15	04:15	04:15	04:15	04:15	04:15	04:15	04:16	04:16	04:16
192	04:16	04:16	04:16	04:16	04:17	04:17	04:17	04:17	04:17	04:17
193	04:17	04:17	04:18	04:18	04:18	04:18	04:18	04:18	04:18	04:19
194	04:19	04:19	04:19	04:19	04:19	04:19	04:19	04:20	04:20	04:20
195	04:20	04:20	04:20	04:20	04:21	04:21	04:21	04:21	04:21	04:21
196	04:21	04:21	04:22	04:22	04:22	04:22	04:22	04:22	04:22	04:23
197	04:23	04:23	04:23	04:23	04:23	04:23	04:23	04:24	04:24	04:24
198	04:24	04:24	04:24	04:24	04:25	04:25	04:25	04:25	04:25	04:25
199	04:25	04:25	04:26	04:26	04:26	04:26	04:26	04:26	04:26	04:27
200	04:27	04:27	04:27	04:27	04:27	04:27	04:27	04:28	04:28	04:28
201	04:28	04:28	04:28	04:28	04:29	04:29	04:29	04:29	04:29	04:29
202	04:29	04:29	04:30	04:30	04:30	04:30	04:30	04:30	04:30	04:31
203	04:31	04:31	04:31	04:31	04:31	04:31	04:31	04:32	04:32	04:32
204	04:32	04:32	04:32	04:32	04:33	04:33	04:33	04:33	04:33	04:33
205	04:33	04:33	04:34	04:34	04:34	04:34	04:34	04:34	04:34	04:35
206	04:35	04:35	04:35	04:35	04:35	04:35	04:35	04:36	04:36	04:36
207	04:36	04:36	04:36	04:36	04:37	04:37	04:37	04:37	04:37	04:37
208	04:37	04:37	04:38	04:38	04:38	04:38	04:38	04:38	04:38	04:39
209	04:39	04:39	04:39	04:39	04:39	04:39	04:39	04:40	04:40	04:40
210	04:40	04:40	04:40	04:40	04:41	04:41	04:41	04:41	04:41	04:41
211	04:41	04:41	04:42	04:42	04:42	04:42	04:42	04:42	04:42	04:43
212	04:43	04:43	04:43	04:43	04:43	04:43	04:43	04:44	04:44	04:44
213	04:44	04:44	04:44	04:44	04:45	04:45	04:45	04:45	04:45	04:45
214	04:45	04:45	04:46	04:46	04:46	04:46	04:46	04:46	04:46	04:47
215	04:47	04:47	04:47	04:47	04:47	04:47	04:47	04:48	04:48	04:48
216	04:48	04:48	04:48	04:48	04:49	04:49	04:49	04:49	04:49	04:49
217	04:49	04:49	04:50	04:50	04:50	04:50	04:50	04:50	04:50	04:51
218	04:51	04:51	04:51	04:51	04:51	04:51	04:51	04:52	04:52	04:52
219	04:52	04:52	04:52	04:52	04:53	04:53	04:53	04:53	04:53	04:53
220	04:53	04:53	04:54	04:54	04:54	04:54	04:54	04:54	04:54	04:55
221	04:55	04:55	04:55	04:55	04:55	04:55	04:55	04:56	04:56	04:56
222	04:56	04:56	04:56	04:56	04:57	04:57	04:57	04:57	04:57	04:57
223	04:57	04:57	04:58	04:58	04:58	04:58	04:58	04:58	04:58	04:59
224	04:59	04:59	04:59	04:59	04:59	04:59	04:59	05:00	05:00	05:00
225	05:00	05:00	05:00	05:00	05:01	05:01	05:01	05:01	05:01	05:01
226	05:01	05:01	05:02	05:02	05:02	05:02	05:02	05:02	05:02	05:03
227	05:03	05:03	05:03	05:03	05:03	05:03	05:03	05:04	05:04	05:04

## Nordic Combined

Time Difference for **Team Sprint / Mixed Team Sprint Competitions**

45.0

Pts/Min = 1.333333 Sec/Pts

Punkte	0.0	0.1	0.2	0.3	0.4	0.5	0.6	0.7	0.8	0.9
228	05:04	05:04	05:04	05:04	05:05	05:05	05:05	05:05	05:05	05:05
229	05:05	05:05	05:06	05:06	05:06	05:06	05:06	05:06	05:06	05:07
230	05:07	05:07	05:07	05:07	05:07	05:07	05:07	05:08	05:08	05:08
231	05:08	05:08	05:08	05:08	05:09	05:09	05:09	05:09	05:09	05:09
232	05:09	05:09	05:10	05:10	05:10	05:10	05:10	05:10	05:10	05:11
233	05:11	05:11	05:11	05:11	05:11	05:11	05:11	05:12	05:12	05:12
234	05:12	05:12	05:12	05:12	05:13	05:13	05:13	05:13	05:13	05:13
235	05:13	05:13	05:14	05:14	05:14	05:14	05:14	05:14	05:14	05:15
236	05:15	05:15	05:15	05:15	05:15	05:15	05:15	05:16	05:16	05:16
237	05:16	05:16	05:16	05:16	05:17	05:17	05:17	05:17	05:17	05:17
238	05:17	05:17	05:18	05:18	05:18	05:18	05:18	05:18	05:18	05:19
239	05:19	05:19	05:19	05:19	05:19	05:19	05:19	05:20	05:20	05:20
240	05:20	05:20	05:20	05:20	05:21	05:21	05:21	05:21	05:21	05:21
241	05:21	05:21	05:22	05:22	05:22	05:22	05:22	05:22	05:22	05:23
242	05:23	05:23	05:23	05:23	05:23	05:23	05:23	05:24	05:24	05:24
243	05:24	05:24	05:24	05:24	05:25	05:25	05:25	05:25	05:25	05:25
244	05:25	05:25	05:26	05:26	05:26	05:26	05:26	05:26	05:26	05:27
245	05:27	05:27	05:27	05:27	05:27	05:27	05:27	05:28	05:28	05:28
246	05:28	05:28	05:28	05:28	05:29	05:29	05:29	05:29	05:29	05:29
247	05:29	05:29	05:30	05:30	05:30	05:30	05:30	05:30	05:30	05:31
248	05:31	05:31	05:31	05:31	05:31	05:31	05:31	05:32	05:32	05:32
249	05:32	05:32	05:32	05:32	05:33	05:33	05:33	05:33	05:33	05:33
250	05:33	05:33	05:34	05:34	05:34	05:34	05:34	05:34	05:34	05:35
251	05:35	05:35	05:35	05:35	05:35	05:35	05:35	05:36	05:36	05:36
252	05:36	05:36	05:36	05:36	05:37	05:37	05:37	05:37	05:37	05:37
253	05:37	05:37	05:38	05:38	05:38	05:38	05:38	05:38	05:38	05:39
254	05:39	05:39	05:39	05:39	05:39	05:39	05:39	05:40	05:40	05:40
255	05:40	05:40	05:40	05:40	05:41	05:41	05:41	05:41	05:41	05:41
256	05:41	05:41	05:42	05:42	05:42	05:42	05:42	05:42	05:42	05:43
257	05:43	05:43	05:43	05:43	05:43	05:43	05:43	05:44	05:44	05:44
258	05:44	05:44	05:44	05:44	05:45	05:45	05:45	05:45	05:45	05:45
259	05:45	05:45	05:46	05:46	05:46	05:46	05:46	05:46	05:46	05:47
260	05:47	05:47	05:47	05:47	05:47	05:47	05:47	05:48	05:48	05:48
261	05:48	05:48	05:48	05:48	05:49	05:49	05:49	05:49	05:49	05:49
262	05:49	05:49	05:50	05:50	05:50	05:50	05:50	05:50	05:50	05:51
263	05:51	05:51	05:51	05:51	05:51	05:51	05:51	05:52	05:52	05:52
264	05:52	05:52	05:52	05:52	05:53	05:53	05:53	05:53	05:53	05:53
265	05:53	05:53	05:54	05:54	05:54	05:54	05:54	05:54	05:54	05:55



## Nordic Combined

Time Difference for **Team Sprint / Mixed Team Sprint Competitions**

**45.0**

Pts/Min = 1.333333 Sec/Pts

Punkte	0.0	0.1	0.2	0.3	0.4	0.5	0.6	0.7	0.8	0.9
<b>266</b>	05:55	05:55	05:55	05:55	05:55	05:55	05:55	05:56	05:56	05:56
<b>267</b>	05:56	05:56	05:56	05:56	05:57	05:57	05:57	05:57	05:57	05:57
<b>268</b>	05:57	05:57	05:58	05:58	05:58	05:58	05:58	05:58	05:58	05:59
<b>269</b>	05:59	05:59	05:59	05:59	05:59	05:59	05:59	06:00	06:00	06:00
<b>270</b>	06:00	06:00	06:00	06:00	06:01	06:01	06:01	06:01	06:01	06:01

## Nordic Combined

Time Difference for **Team / Mixed Team Competitions**

60.0

Pts/Min = 1.000000 Sec/Pts

Punkte	0.0	0.1	0.2	0.3	0.4	0.5	0.6	0.7	0.8	0.9
<b>0</b>	00:00	00:00	00:00	00:00	00:00	00:01	00:01	00:01	00:01	00:01
<b>1</b>	00:01	00:01	00:01	00:01	00:01	00:02	00:02	00:02	00:02	00:02
<b>2</b>	00:02	00:02	00:02	00:02	00:02	00:03	00:03	00:03	00:03	00:03
<b>3</b>	00:03	00:03	00:03	00:03	00:03	00:04	00:04	00:04	00:04	00:04
<b>4</b>	00:04	00:04	00:04	00:04	00:04	00:05	00:05	00:05	00:05	00:05
<b>5</b>	00:05	00:05	00:05	00:05	00:05	00:06	00:06	00:06	00:06	00:06
<b>6</b>	00:06	00:06	00:06	00:06	00:06	00:07	00:07	00:07	00:07	00:07
<b>7</b>	00:07	00:07	00:07	00:07	00:07	00:08	00:08	00:08	00:08	00:08
<b>8</b>	00:08	00:08	00:08	00:08	00:08	00:09	00:09	00:09	00:09	00:09
<b>9</b>	00:09	00:09	00:09	00:09	00:09	00:10	00:10	00:10	00:10	00:10
<b>10</b>	00:10	00:10	00:10	00:10	00:10	00:11	00:11	00:11	00:11	00:11
<b>11</b>	00:11	00:11	00:11	00:11	00:11	00:12	00:12	00:12	00:12	00:12
<b>12</b>	00:12	00:12	00:12	00:12	00:12	00:13	00:13	00:13	00:13	00:13
<b>13</b>	00:13	00:13	00:13	00:13	00:13	00:14	00:14	00:14	00:14	00:14
<b>14</b>	00:14	00:14	00:14	00:14	00:14	00:15	00:15	00:15	00:15	00:15
<b>15</b>	00:15	00:15	00:15	00:15	00:15	00:16	00:16	00:16	00:16	00:16
<b>16</b>	00:16	00:16	00:16	00:16	00:16	00:17	00:17	00:17	00:17	00:17
<b>17</b>	00:17	00:17	00:17	00:17	00:17	00:18	00:18	00:18	00:18	00:18
<b>18</b>	00:18	00:18	00:18	00:18	00:18	00:19	00:19	00:19	00:19	00:19
<b>19</b>	00:19	00:19	00:19	00:19	00:19	00:20	00:20	00:20	00:20	00:20
<b>20</b>	00:20	00:20	00:20	00:20	00:20	00:21	00:21	00:21	00:21	00:21
<b>21</b>	00:21	00:21	00:21	00:21	00:21	00:22	00:22	00:22	00:22	00:22
<b>22</b>	00:22	00:22	00:22	00:22	00:22	00:23	00:23	00:23	00:23	00:23
<b>23</b>	00:23	00:23	00:23	00:23	00:23	00:24	00:24	00:24	00:24	00:24
<b>24</b>	00:24	00:24	00:24	00:24	00:24	00:25	00:25	00:25	00:25	00:25
<b>25</b>	00:25	00:25	00:25	00:25	00:25	00:26	00:26	00:26	00:26	00:26
<b>26</b>	00:26	00:26	00:26	00:26	00:26	00:27	00:27	00:27	00:27	00:27
<b>27</b>	00:27	00:27	00:27	00:27	00:27	00:28	00:28	00:28	00:28	00:28
<b>28</b>	00:28	00:28	00:28	00:28	00:28	00:29	00:29	00:29	00:29	00:29
<b>29</b>	00:29	00:29	00:29	00:29	00:29	00:30	00:30	00:30	00:30	00:30
<b>30</b>	00:30	00:30	00:30	00:30	00:30	00:31	00:31	00:31	00:31	00:31
<b>31</b>	00:31	00:31	00:31	00:31	00:31	00:32	00:32	00:32	00:32	00:32
<b>32</b>	00:32	00:32	00:32	00:32	00:32	00:33	00:33	00:33	00:33	00:33
<b>33</b>	00:33	00:33	00:33	00:33	00:33	00:34	00:34	00:34	00:34	00:34
<b>34</b>	00:34	00:34	00:34	00:34	00:34	00:35	00:35	00:35	00:35	00:35
<b>35</b>	00:35	00:35	00:35	00:35	00:35	00:36	00:36	00:36	00:36	00:36
<b>36</b>	00:36	00:36	00:36	00:36	00:36	00:37	00:37	00:37	00:37	00:37
<b>37</b>	00:37	00:37	00:37	00:37	00:37	00:38	00:38	00:38	00:38	00:38

## Nordic Combined

Time Difference for **Team / Mixed Team Competitions**

**60.0**

Pts/Min = 1.000000 Sec/Pts

Punkte	0.0	0.1	0.2	0.3	0.4	0.5	0.6	0.7	0.8	0.9
38	00:38	00:38	00:38	00:38	00:38	00:39	00:39	00:39	00:39	00:39
39	00:39	00:39	00:39	00:39	00:39	00:40	00:40	00:40	00:40	00:40
40	00:40	00:40	00:40	00:40	00:40	00:41	00:41	00:41	00:41	00:41
41	00:41	00:41	00:41	00:41	00:41	00:42	00:42	00:42	00:42	00:42
42	00:42	00:42	00:42	00:42	00:42	00:43	00:43	00:43	00:43	00:43
43	00:43	00:43	00:43	00:43	00:43	00:44	00:44	00:44	00:44	00:44
44	00:44	00:44	00:44	00:44	00:44	00:45	00:45	00:45	00:45	00:45
45	00:45	00:45	00:45	00:45	00:45	00:46	00:46	00:46	00:46	00:46
46	00:46	00:46	00:46	00:46	00:46	00:47	00:47	00:47	00:47	00:47
47	00:47	00:47	00:47	00:47	00:47	00:48	00:48	00:48	00:48	00:48
48	00:48	00:48	00:48	00:48	00:48	00:49	00:49	00:49	00:49	00:49
49	00:49	00:49	00:49	00:49	00:49	00:50	00:50	00:50	00:50	00:50
50	00:50	00:50	00:50	00:50	00:50	00:51	00:51	00:51	00:51	00:51
51	00:51	00:51	00:51	00:51	00:51	00:52	00:52	00:52	00:52	00:52
52	00:52	00:52	00:52	00:52	00:52	00:53	00:53	00:53	00:53	00:53
53	00:53	00:53	00:53	00:53	00:53	00:54	00:54	00:54	00:54	00:54
54	00:54	00:54	00:54	00:54	00:54	00:55	00:55	00:55	00:55	00:55
55	00:55	00:55	00:55	00:55	00:55	00:56	00:56	00:56	00:56	00:56
56	00:56	00:56	00:56	00:56	00:56	00:57	00:57	00:57	00:57	00:57
57	00:57	00:57	00:57	00:57	00:57	00:58	00:58	00:58	00:58	00:58
58	00:58	00:58	00:58	00:58	00:58	00:59	00:59	00:59	00:59	00:59
59	00:59	00:59	00:59	00:59	00:59	01:00	01:00	01:00	01:00	01:00
60	01:00	01:00	01:00	01:00	01:00	01:01	01:01	01:01	01:01	01:01
61	01:01	01:01	01:01	01:01	01:01	01:02	01:02	01:02	01:02	01:02
62	01:02	01:02	01:02	01:02	01:02	01:03	01:03	01:03	01:03	01:03
63	01:03	01:03	01:03	01:03	01:03	01:04	01:04	01:04	01:04	01:04
64	01:04	01:04	01:04	01:04	01:04	01:05	01:05	01:05	01:05	01:05
65	01:05	01:05	01:05	01:05	01:05	01:06	01:06	01:06	01:06	01:06
66	01:06	01:06	01:06	01:06	01:06	01:07	01:07	01:07	01:07	01:07
67	01:07	01:07	01:07	01:07	01:07	01:08	01:08	01:08	01:08	01:08
68	01:08	01:08	01:08	01:08	01:08	01:09	01:09	01:09	01:09	01:09
69	01:09	01:09	01:09	01:09	01:09	01:10	01:10	01:10	01:10	01:10
70	01:10	01:10	01:10	01:10	01:10	01:11	01:11	01:11	01:11	01:11
71	01:11	01:11	01:11	01:11	01:11	01:12	01:12	01:12	01:12	01:12
72	01:12	01:12	01:12	01:12	01:12	01:13	01:13	01:13	01:13	01:13
73	01:13	01:13	01:13	01:13	01:13	01:14	01:14	01:14	01:14	01:14
74	01:14	01:14	01:14	01:14	01:14	01:15	01:15	01:15	01:15	01:15
75	01:15	01:15	01:15	01:15	01:15	01:16	01:16	01:16	01:16	01:16

## Nordic Combined

Time Difference for **Team / Mixed Team Competitions**

**60.0**

Pts/Min = 1.000000 Sec/Pts

Punkte	0.0	0.1	0.2	0.3	0.4	0.5	0.6	0.7	0.8	0.9
76	01:16	01:16	01:16	01:16	01:16	01:17	01:17	01:17	01:17	01:17
77	01:17	01:17	01:17	01:17	01:17	01:18	01:18	01:18	01:18	01:18
78	01:18	01:18	01:18	01:18	01:18	01:19	01:19	01:19	01:19	01:19
79	01:19	01:19	01:19	01:19	01:19	01:20	01:20	01:20	01:20	01:20
80	01:20	01:20	01:20	01:20	01:20	01:21	01:21	01:21	01:21	01:21
81	01:21	01:21	01:21	01:21	01:21	01:22	01:22	01:22	01:22	01:22
82	01:22	01:22	01:22	01:22	01:22	01:23	01:23	01:23	01:23	01:23
83	01:23	01:23	01:23	01:23	01:23	01:24	01:24	01:24	01:24	01:24
84	01:24	01:24	01:24	01:24	01:24	01:25	01:25	01:25	01:25	01:25
85	01:25	01:25	01:25	01:25	01:25	01:26	01:26	01:26	01:26	01:26
86	01:26	01:26	01:26	01:26	01:26	01:27	01:27	01:27	01:27	01:27
87	01:27	01:27	01:27	01:27	01:27	01:28	01:28	01:28	01:28	01:28
88	01:28	01:28	01:28	01:28	01:28	01:29	01:29	01:29	01:29	01:29
89	01:29	01:29	01:29	01:29	01:29	01:30	01:30	01:30	01:30	01:30
90	01:30	01:30	01:30	01:30	01:30	01:31	01:31	01:31	01:31	01:31
91	01:31	01:31	01:31	01:31	01:31	01:32	01:32	01:32	01:32	01:32
92	01:32	01:32	01:32	01:32	01:32	01:33	01:33	01:33	01:33	01:33
93	01:33	01:33	01:33	01:33	01:33	01:34	01:34	01:34	01:34	01:34
94	01:34	01:34	01:34	01:34	01:34	01:35	01:35	01:35	01:35	01:35
95	01:35	01:35	01:35	01:35	01:35	01:36	01:36	01:36	01:36	01:36
96	01:36	01:36	01:36	01:36	01:36	01:37	01:37	01:37	01:37	01:37
97	01:37	01:37	01:37	01:37	01:37	01:38	01:38	01:38	01:38	01:38
98	01:38	01:38	01:38	01:38	01:38	01:39	01:39	01:39	01:39	01:39
99	01:39	01:39	01:39	01:39	01:39	01:40	01:40	01:40	01:40	01:40
100	01:40	01:40	01:40	01:40	01:40	01:41	01:41	01:41	01:41	01:41
101	01:41	01:41	01:41	01:41	01:41	01:42	01:42	01:42	01:42	01:42
102	01:42	01:42	01:42	01:42	01:42	01:43	01:43	01:43	01:43	01:43
103	01:43	01:43	01:43	01:43	01:43	01:44	01:44	01:44	01:44	01:44
104	01:44	01:44	01:44	01:44	01:44	01:45	01:45	01:45	01:45	01:45
105	01:45	01:45	01:45	01:45	01:45	01:46	01:46	01:46	01:46	01:46
106	01:46	01:46	01:46	01:46	01:46	01:47	01:47	01:47	01:47	01:47
107	01:47	01:47	01:47	01:47	01:47	01:48	01:48	01:48	01:48	01:48
108	01:48	01:48	01:48	01:48	01:48	01:49	01:49	01:49	01:49	01:49
109	01:49	01:49	01:49	01:49	01:49	01:50	01:50	01:50	01:50	01:50
110	01:50	01:50	01:50	01:50	01:50	01:51	01:51	01:51	01:51	01:51
111	01:51	01:51	01:51	01:51	01:51	01:52	01:52	01:52	01:52	01:52
112	01:52	01:52	01:52	01:52	01:52	01:53	01:53	01:53	01:53	01:53
113	01:53	01:53	01:53	01:53	01:53	01:54	01:54	01:54	01:54	01:54

## Nordic Combined

Time Difference for **Team / Mixed Team Competitions**

**60.0**

Pts/Min = 1.000000 Sec/Pts

Punkte	0.0	0.1	0.2	0.3	0.4	0.5	0.6	0.7	0.8	0.9
114	01:54	01:54	01:54	01:54	01:54	01:55	01:55	01:55	01:55	01:55
115	01:55	01:55	01:55	01:55	01:55	01:56	01:56	01:56	01:56	01:56
116	01:56	01:56	01:56	01:56	01:56	01:57	01:57	01:57	01:57	01:57
117	01:57	01:57	01:57	01:57	01:57	01:58	01:58	01:58	01:58	01:58
118	01:58	01:58	01:58	01:58	01:58	01:59	01:59	01:59	01:59	01:59
119	01:59	01:59	01:59	01:59	01:59	02:00	02:00	02:00	02:00	02:00
120	02:00	02:00	02:00	02:00	02:00	02:01	02:01	02:01	02:01	02:01
121	02:01	02:01	02:01	02:01	02:01	02:02	02:02	02:02	02:02	02:02
122	02:02	02:02	02:02	02:02	02:02	02:03	02:03	02:03	02:03	02:03
123	02:03	02:03	02:03	02:03	02:03	02:04	02:04	02:04	02:04	02:04
124	02:04	02:04	02:04	02:04	02:04	02:05	02:05	02:05	02:05	02:05
125	02:05	02:05	02:05	02:05	02:05	02:06	02:06	02:06	02:06	02:06
126	02:06	02:06	02:06	02:06	02:06	02:07	02:07	02:07	02:07	02:07
127	02:07	02:07	02:07	02:07	02:07	02:08	02:08	02:08	02:08	02:08
128	02:08	02:08	02:08	02:08	02:08	02:09	02:09	02:09	02:09	02:09
129	02:09	02:09	02:09	02:09	02:09	02:10	02:10	02:10	02:10	02:10
130	02:10	02:10	02:10	02:10	02:10	02:11	02:11	02:11	02:11	02:11
131	02:11	02:11	02:11	02:11	02:11	02:12	02:12	02:12	02:12	02:12
132	02:12	02:12	02:12	02:12	02:12	02:13	02:13	02:13	02:13	02:13
133	02:13	02:13	02:13	02:13	02:13	02:14	02:14	02:14	02:14	02:14
134	02:14	02:14	02:14	02:14	02:14	02:15	02:15	02:15	02:15	02:15
135	02:15	02:15	02:15	02:15	02:15	02:16	02:16	02:16	02:16	02:16
136	02:16	02:16	02:16	02:16	02:16	02:17	02:17	02:17	02:17	02:17
137	02:17	02:17	02:17	02:17	02:17	02:18	02:18	02:18	02:18	02:18
138	02:18	02:18	02:18	02:18	02:18	02:19	02:19	02:19	02:19	02:19
139	02:19	02:19	02:19	02:19	02:19	02:20	02:20	02:20	02:20	02:20
140	02:20	02:20	02:20	02:20	02:20	02:21	02:21	02:21	02:21	02:21
141	02:21	02:21	02:21	02:21	02:21	02:22	02:22	02:22	02:22	02:22
142	02:22	02:22	02:22	02:22	02:22	02:23	02:23	02:23	02:23	02:23
143	02:23	02:23	02:23	02:23	02:23	02:24	02:24	02:24	02:24	02:24
144	02:24	02:24	02:24	02:24	02:24	02:25	02:25	02:25	02:25	02:25
145	02:25	02:25	02:25	02:25	02:25	02:26	02:26	02:26	02:26	02:26
146	02:26	02:26	02:26	02:26	02:26	02:27	02:27	02:27	02:27	02:27
147	02:27	02:27	02:27	02:27	02:27	02:28	02:28	02:28	02:28	02:28
148	02:28	02:28	02:28	02:28	02:28	02:29	02:29	02:29	02:29	02:29
149	02:29	02:29	02:29	02:29	02:29	02:30	02:30	02:30	02:30	02:30
150	02:30	02:30	02:30	02:30	02:30	02:31	02:31	02:31	02:31	02:31
151	02:31	02:31	02:31	02:31	02:31	02:32	02:32	02:32	02:32	02:32

## Nordic Combined

Time Difference for **Team / Mixed Team Competitions**

<b>60.0</b>
-------------

Pts/Min = 1.000000 Sec/Pts

Punkte	0.0	0.1	0.2	0.3	0.4	0.5	0.6	0.7	0.8	0.9
<b>152</b>	02:32	02:32	02:32	02:32	02:32	02:33	02:33	02:33	02:33	02:33
<b>153</b>	02:33	02:33	02:33	02:33	02:33	02:34	02:34	02:34	02:34	02:34
<b>154</b>	02:34	02:34	02:34	02:34	02:34	02:35	02:35	02:35	02:35	02:35
<b>155</b>	02:35	02:35	02:35	02:35	02:35	02:36	02:36	02:36	02:36	02:36
<b>156</b>	02:36	02:36	02:36	02:36	02:36	02:37	02:37	02:37	02:37	02:37
<b>157</b>	02:37	02:37	02:37	02:37	02:37	02:38	02:38	02:38	02:38	02:38
<b>158</b>	02:38	02:38	02:38	02:38	02:38	02:39	02:39	02:39	02:39	02:39
<b>159</b>	02:39	02:39	02:39	02:39	02:39	02:40	02:40	02:40	02:40	02:40
<b>160</b>	02:40	02:40	02:40	02:40	02:40	02:41	02:41	02:41	02:41	02:41
<b>160</b>	02:41	02:41	02:41	02:41	02:41	02:42	02:42	02:42	02:42	02:42
<b>162</b>	02:42	02:42	02:42	02:42	02:42	02:43	02:43	02:43	02:43	02:43
<b>163</b>	02:43	02:43	02:43	02:43	02:43	02:44	02:44	02:44	02:44	02:44
<b>164</b>	02:44	02:44	02:44	02:44	02:44	02:45	02:45	02:45	02:45	02:45
<b>165</b>	02:45	02:45	02:45	02:45	02:45	02:46	02:46	02:46	02:46	02:46
<b>166</b>	02:46	02:46	02:46	02:46	02:46	02:47	02:47	02:47	02:47	02:47
<b>167</b>	02:47	02:47	02:47	02:47	02:47	02:48	02:48	02:48	02:48	02:48
<b>168</b>	02:48	02:48	02:48	02:48	02:48	02:49	02:49	02:49	02:49	02:49
<b>169</b>	02:49	02:49	02:49	02:49	02:49	02:50	02:50	02:50	02:50	02:50
<b>170</b>	02:50	02:50	02:50	02:50	02:50	02:51	02:51	02:51	02:51	02:51
<b>171</b>	02:51	02:51	02:51	02:51	02:51	02:52	02:52	02:52	02:52	02:52
<b>172</b>	02:52	02:52	02:52	02:52	02:52	02:53	02:53	02:53	02:53	02:53
<b>173</b>	02:53	02:53	02:53	02:53	02:53	02:54	02:54	02:54	02:54	02:54
<b>174</b>	02:54	02:54	02:54	02:54	02:54	02:55	02:55	02:55	02:55	02:55
<b>175</b>	02:55	02:55	02:55	02:55	02:55	02:56	02:56	02:56	02:56	02:56
<b>176</b>	02:56	02:56	02:56	02:56	02:56	02:57	02:57	02:57	02:57	02:57
<b>177</b>	02:57	02:57	02:57	02:57	02:57	02:58	02:58	02:58	02:58	02:58
<b>178</b>	02:58	02:58	02:58	02:58	02:58	02:59	02:59	02:59	02:59	02:59
<b>179</b>	02:59	02:59	02:59	02:59	02:59	03:00	03:00	03:00	03:00	03:00
<b>180</b>	03:00	03:00	03:00	03:00	03:00	03:01	03:01	03:01	03:01	03:01
<b>181</b>	03:01	03:01	03:01	03:01	03:01	03:02	03:02	03:02	03:02	03:02
<b>182</b>	03:02	03:02	03:02	03:02	03:02	03:03	03:03	03:03	03:03	03:03
<b>183</b>	03:03	03:03	03:03	03:03	03:03	03:04	03:04	03:04	03:04	03:04
<b>184</b>	03:04	03:04	03:04	03:04	03:04	03:05	03:05	03:05	03:05	03:05
<b>185</b>	03:05	03:05	03:05	03:05	03:05	03:06	03:06	03:06	03:06	03:06
<b>186</b>	03:06	03:06	03:06	03:06	03:06	03:07	03:07	03:07	03:07	03:07
<b>187</b>	03:07	03:07	03:07	03:07	03:07	03:08	03:08	03:08	03:08	03:08
<b>188</b>	03:08	03:08	03:08	03:08	03:08	03:09	03:09	03:09	03:09	03:09
<b>189</b>	03:09	03:09	03:09	03:09	03:09	03:10	03:10	03:10	03:10	03:10

## Nordic Combined

Time Difference for **Team / Mixed Team Competitions**

**60.0**

Pts/Min = 1.000000 Sec/Pts

Punkte	0.0	0.1	0.2	0.3	0.4	0.5	0.6	0.7	0.8	0.9
190	03:10	03:10	03:10	03:10	03:10	03:11	03:11	03:11	03:11	03:11
191	03:11	03:11	03:11	03:11	03:11	03:12	03:12	03:12	03:12	03:12
192	03:12	03:12	03:12	03:12	03:12	03:13	03:13	03:13	03:13	03:13
193	03:13	03:13	03:13	03:13	03:13	03:14	03:14	03:14	03:14	03:14
194	03:14	03:14	03:14	03:14	03:14	03:15	03:15	03:15	03:15	03:15
195	03:15	03:15	03:15	03:15	03:15	03:16	03:16	03:16	03:16	03:16
196	03:16	03:16	03:16	03:16	03:16	03:17	03:17	03:17	03:17	03:17
197	03:17	03:17	03:17	03:17	03:17	03:18	03:18	03:18	03:18	03:18
198	03:18	03:18	03:18	03:18	03:18	03:19	03:19	03:19	03:19	03:19
199	03:19	03:19	03:19	03:19	03:19	03:20	03:20	03:20	03:20	03:20
200	03:20	03:20	03:20	03:20	03:20	03:21	03:21	03:21	03:21	03:21
201	03:21	03:21	03:21	03:21	03:21	03:22	03:22	03:22	03:22	03:22
202	03:22	03:22	03:22	03:22	03:22	03:23	03:23	03:23	03:23	03:23
203	03:23	03:23	03:23	03:23	03:23	03:24	03:24	03:24	03:24	03:24
204	03:24	03:24	03:24	03:24	03:24	03:25	03:25	03:25	03:25	03:25
205	03:25	03:25	03:25	03:25	03:25	03:26	03:26	03:26	03:26	03:26
206	03:26	03:26	03:26	03:26	03:26	03:27	03:27	03:27	03:27	03:27
207	03:27	03:27	03:27	03:27	03:27	03:28	03:28	03:28	03:28	03:28
208	03:28	03:28	03:28	03:28	03:28	03:29	03:29	03:29	03:29	03:29
209	03:29	03:29	03:29	03:29	03:29	03:30	03:30	03:30	03:30	03:30
210	03:30	03:30	03:30	03:30	03:30	03:31	03:31	03:31	03:31	03:31
211	03:31	03:31	03:31	03:31	03:31	03:32	03:32	03:32	03:32	03:32
212	03:32	03:32	03:32	03:32	03:32	03:33	03:33	03:33	03:33	03:33
213	03:33	03:33	03:33	03:33	03:33	03:34	03:34	03:34	03:34	03:34
214	03:34	03:34	03:34	03:34	03:34	03:35	03:35	03:35	03:35	03:35
215	03:35	03:35	03:35	03:35	03:35	03:36	03:36	03:36	03:36	03:36
216	03:36	03:36	03:36	03:36	03:36	03:37	03:37	03:37	03:37	03:37
217	03:37	03:37	03:37	03:37	03:37	03:38	03:38	03:38	03:38	03:38
218	03:38	03:38	03:38	03:38	03:38	03:39	03:39	03:39	03:39	03:39
219	03:39	03:39	03:39	03:39	03:39	03:40	03:40	03:40	03:40	03:40
220	03:40	03:40	03:40	03:40	03:40	03:41	03:41	03:41	03:41	03:41
221	03:41	03:41	03:41	03:41	03:41	03:42	03:42	03:42	03:42	03:42
222	03:42	03:42	03:42	03:42	03:42	03:43	03:43	03:43	03:43	03:43
223	03:43	03:43	03:43	03:43	03:43	03:44	03:44	03:44	03:44	03:44
224	03:44	03:44	03:44	03:44	03:44	03:45	03:45	03:45	03:45	03:45
255	03:45	03:45	03:45	03:45	03:45	03:46	03:46	03:46	03:46	03:46
256	03:46	03:46	03:46	03:46	03:46	03:47	03:47	03:47	03:47	03:47
257	03:47	03:47	03:47	03:47	03:47	03:48	03:48	03:48	03:48	03:48

## Nordic Combined

Time Difference for **Team / Mixed Team Competitions**

**60.0**

Pts/Min = 1.000000 Sec/Pts

Punkte	0.0	0.1	0.2	0.3	0.4	0.5	0.6	0.7	0.8	0.9
258	03:48	03:48	03:48	03:48	03:48	03:49	03:49	03:49	03:49	03:49
259	03:49	03:49	03:49	03:49	03:49	03:50	03:50	03:50	03:50	03:50
260	03:50	03:50	03:50	03:50	03:50	03:51	03:51	03:51	03:51	03:51
261	03:51	03:51	03:51	03:51	03:51	03:52	03:52	03:52	03:52	03:52
262	03:52	03:52	03:52	03:52	03:52	03:53	03:53	03:53	03:53	03:53
263	03:53	03:53	03:53	03:53	03:53	03:54	03:54	03:54	03:54	03:54
264	03:54	03:54	03:54	03:54	03:54	03:55	03:55	03:55	03:55	03:55
265	03:55	03:55	03:55	03:55	03:55	03:56	03:56	03:56	03:56	03:56
266	03:56	03:56	03:56	03:56	03:56	03:57	03:57	03:57	03:57	03:57
267	03:57	03:57	03:57	03:57	03:57	03:58	03:58	03:58	03:58	03:58
268	03:58	03:58	03:58	03:58	03:58	03:59	03:59	03:59	03:59	03:59
269	03:59	03:59	03:59	03:59	03:59	04:00	04:00	04:00	04:00	04:00
270	04:00	04:00	04:00	04:00	04:00	04:01	04:01	04:01	04:01	04:01
271	04:01	04:01	04:01	04:01	04:01	04:02	04:02	04:02	04:02	04:02
272	04:02	04:02	04:02	04:02	04:02	04:03	04:03	04:03	04:03	04:03
273	04:03	04:03	04:03	04:03	04:03	04:04	04:04	04:04	04:04	04:04
274	04:04	04:04	04:04	04:04	04:04	04:05	04:05	04:05	04:05	04:05
275	04:05	04:05	04:05	04:05	04:05	04:06	04:06	04:06	04:06	04:06
276	04:06	04:06	04:06	04:06	04:06	04:07	04:07	04:07	04:07	04:07
277	04:07	04:07	04:07	04:07	04:07	04:08	04:08	04:08	04:08	04:08
278	04:08	04:08	04:08	04:08	04:08	04:09	04:09	04:09	04:09	04:09
279	04:09	04:09	04:09	04:09	04:09	04:10	04:10	04:10	04:10	04:10
280	04:10	04:10	04:10	04:10	04:10	04:11	04:11	04:11	04:11	04:11
281	04:11	04:11	04:11	04:11	04:11	04:12	04:12	04:12	04:12	04:12
282	04:12	04:12	04:12	04:12	04:12	04:13	04:13	04:13	04:13	04:13
283	04:13	04:13	04:13	04:13	04:13	04:14	04:14	04:14	04:14	04:14
284	04:14	04:14	04:14	04:14	04:14	04:15	04:15	04:15	04:15	04:15
285	04:15	04:15	04:15	04:15	04:15	04:16	04:16	04:16	04:16	04:16
286	04:16	04:16	04:16	04:16	04:16	04:17	04:17	04:17	04:17	04:17
287	04:17	04:17	04:17	04:17	04:17	04:18	04:18	04:18	04:18	04:18
288	04:18	04:18	04:18	04:18	04:18	04:19	04:19	04:19	04:19	04:19
289	04:19	04:19	04:19	04:19	04:19	04:20	04:20	04:20	04:20	04:20
290	04:20	04:20	04:20	04:20	04:20	04:21	04:21	04:21	04:21	04:21
291	04:21	04:21	04:21	04:21	04:21	04:22	04:22	04:22	04:22	04:22
292	04:22	04:22	04:22	04:22	04:22	04:23	04:23	04:23	04:23	04:23
293	04:23	04:23	04:23	04:23	04:23	04:24	04:24	04:24	04:24	04:24
294	04:24	04:24	04:24	04:24	04:24	04:25	04:25	04:25	04:25	04:25
295	04:25	04:25	04:25	04:25	04:25	04:26	04:26	04:26	04:26	04:26



## Nordic Combined

Time Difference for **Team / Mixed Team Competitions**

**60.0**

Pts/Min = 1.000000 Sec/Pts

Punkte	0.0	0.1	0.2	0.3	0.4	0.5	0.6	0.7	0.8	0.9
296	04:26	04:26	04:26	04:26	04:26	04:27	04:27	04:27	04:27	04:27
297	04:27	04:27	04:27	04:27	04:27	04:28	04:28	04:28	04:28	04:28
298	04:28	04:28	04:28	04:28	04:28	04:29	04:29	04:29	04:29	04:29
299	04:29	04:29	04:29	04:29	04:29	04:30	04:30	04:30	04:30	04:30
300	04:30	04:30	04:30	04:30	04:30	04:31	04:31	04:31	04:31	04:31
301	04:31	04:31	04:31	04:31	04:31	04:32	04:32	04:32	04:32	04:32
302	04:32	04:32	04:32	04:32	04:32	04:33	04:33	04:33	04:33	04:33
303	04:33	04:33	04:33	04:33	04:33	04:34	04:34	04:34	04:34	04:34
304	04:34	04:34	04:34	04:34	04:34	04:35	04:35	04:35	04:35	04:35
305	04:35	04:35	04:35	04:35	04:35	04:36	04:36	04:36	04:36	04:36
306	04:36	04:36	04:36	04:36	04:36	04:37	04:37	04:37	04:37	04:37
307	04:37	04:37	04:37	04:37	04:37	04:38	04:38	04:38	04:38	04:38
308	04:38	04:38	04:38	04:38	04:38	04:39	04:39	04:39	04:39	04:39
309	04:39	04:39	04:39	04:39	04:39	04:40	04:40	04:40	04:40	04:40
310	04:40	04:40	04:40	04:40	04:40	04:41	04:41	04:41	04:41	04:41
311	04:41	04:41	04:41	04:41	04:41	04:42	04:42	04:42	04:42	04:42
312	04:42	04:42	04:42	04:42	04:42	04:43	04:43	04:43	04:43	04:43
313	04:43	04:43	04:43	04:43	04:43	04:44	04:44	04:44	04:44	04:44
314	04:44	04:44	04:44	04:44	04:44	04:45	04:45	04:45	04:45	04:45
315	04:45	04:45	04:45	04:45	04:45	04:46	04:46	04:46	04:46	04:46
316	04:46	04:46	04:46	04:46	04:46	04:47	04:47	04:47	04:47	04:47
317	04:47	04:47	04:47	04:47	04:47	04:48	04:48	04:48	04:48	04:48
318	04:48	04:48	04:48	04:48	04:48	04:49	04:49	04:49	04:49	04:49
319	04:49	04:49	04:49	04:49	04:49	04:50	04:50	04:50	04:50	04:50
320	04:50	04:50	04:50	04:50	04:50	04:51	04:51	04:51	04:51	04:51
321	04:51	04:51	04:51	04:51	04:51	04:52	04:52	04:52	04:52	04:52
322	04:52	04:52	04:52	04:52	04:52	04:53	04:53	04:53	04:53	04:53
323	04:53	04:53	04:53	04:53	04:53	04:54	04:54	04:54	04:54	04:54
324	04:54	04:54	04:54	04:54	04:54	04:55	04:55	04:55	04:55	04:55
325	04:55	04:55	04:55	04:55	04:55	04:56	04:56	04:56	04:56	04:56
326	04:56	04:56	04:56	04:56	04:56	04:57	04:57	04:57	04:57	04:57
327	04:57	04:57	04:57	04:57	04:57	04:58	04:58	04:58	04:58	04:58
328	04:58	04:58	04:58	04:58	04:58	04:59	04:59	04:59	04:59	04:59
329	04:59	04:59	04:59	04:59	04:59	05:00	05:00	05:00	05:00	05:00
400	05:00	05:00	05:00	05:00	05:00	05:01	05:01	05:01	05:01	05:01
401	05:01	05:01	05:01	05:01	05:01	05:02	05:02	05:02	05:02	05:02
402	05:02	05:02	05:02	05:02	05:02	05:03	05:03	05:03	05:03	05:03
403	05:03	05:03	05:03	05:03	05:03	05:04	05:04	05:04	05:04	05:04

## Nordic Combined

Time Difference for **Team / Mixed Team Competitions**

**60.0**

Pts/Min = 1.000000 Sec/Pts

Punkte	0.0	0.1	0.2	0.3	0.4	0.5	0.6	0.7	0.8	0.9
404	05:04	05:04	05:04	05:04	05:04	05:05	05:05	05:05	05:05	05:05
405	05:05	05:05	05:05	05:05	05:05	05:06	05:06	05:06	05:06	05:06
406	05:06	05:06	05:06	05:06	05:06	05:07	05:07	05:07	05:07	05:07
407	05:07	05:07	05:07	05:07	05:07	05:08	05:08	05:08	05:08	05:08
408	05:08	05:08	05:08	05:08	05:08	05:09	05:09	05:09	05:09	05:09
409	05:09	05:09	05:09	05:09	05:09	05:10	05:10	05:10	05:10	05:10
410	05:10	05:10	05:10	05:10	05:10	05:11	05:11	05:11	05:11	05:11
411	05:11	05:11	05:11	05:11	05:11	05:12	05:12	05:12	05:12	05:12
412	05:12	05:12	05:12	05:12	05:12	05:13	05:13	05:13	05:13	05:13
413	05:13	05:13	05:13	05:13	05:13	05:14	05:14	05:14	05:14	05:14
414	05:14	05:14	05:14	05:14	05:14	05:15	05:15	05:15	05:15	05:15
415	05:15	05:15	05:15	05:15	05:15	05:16	05:16	05:16	05:16	05:16
416	05:16	05:16	05:16	05:16	05:16	05:17	05:17	05:17	05:17	05:17
417	05:17	05:17	05:17	05:17	05:17	05:18	05:18	05:18	05:18	05:18
418	05:18	05:18	05:18	05:18	05:18	05:19	05:19	05:19	05:19	05:19
419	05:19	05:19	05:19	05:19	05:19	05:20	05:20	05:20	05:20	05:20
420	05:20	05:20	05:20	05:20	05:20	05:21	05:21	05:21	05:21	05:21
421	05:21	05:21	05:21	05:21	05:21	05:22	05:22	05:22	05:22	05:22
422	05:22	05:22	05:22	05:22	05:22	05:23	05:23	05:23	05:23	05:23
423	05:23	05:23	05:23	05:23	05:23	05:24	05:24	05:24	05:24	05:24
424	05:24	05:24	05:24	05:24	05:24	05:25	05:25	05:25	05:25	05:25
425	05:25	05:25	05:25	05:25	05:25	05:26	05:26	05:26	05:26	05:26
426	05:26	05:26	05:26	05:26	05:26	05:27	05:27	05:27	05:27	05:27
427	05:27	05:27	05:27	05:27	05:27	05:28	05:28	05:28	05:28	05:28
428	05:28	05:28	05:28	05:28	05:28	05:29	05:29	05:29	05:29	05:29
429	05:29	05:29	05:29	05:29	05:29	05:30	05:30	05:30	05:30	05:30
430	05:30	05:30	05:30	05:30	05:30	05:31	05:31	05:31	05:31	05:31
431	05:31	05:31	05:31	05:31	05:31	05:32	05:32	05:32	05:32	05:32
432	05:32	05:32	05:32	05:32	05:32	05:33	05:33	05:33	05:33	05:33
433	05:33	05:33	05:33	05:33	05:33	05:34	05:34	05:34	05:34	05:34
434	05:34	05:34	05:34	05:34	05:34	05:35	05:35	05:35	05:35	05:35
435	05:35	05:35	05:35	05:35	05:35	05:36	05:36	05:36	05:36	05:36
436	05:36	05:36	05:36	05:36	05:36	05:37	05:37	05:37	05:37	05:37
437	05:37	05:37	05:37	05:37	05:37	05:38	05:38	05:38	05:38	05:38
438	05:38	05:38	05:38	05:38	05:38	05:39	05:39	05:39	05:39	05:39
439	05:39	05:39	05:39	05:39	05:39	05:40	05:40	05:40	05:40	05:40
440	05:40	05:40	05:40	05:40	05:40	05:41	05:41	05:41	05:41	05:41
441	05:41	05:41	05:41	05:41	05:41	05:42	05:42	05:42	05:42	05:42

## Nordic Combined

Time Difference for **Team / Mixed Team Competitions**

**60.0**

Pts/Min = 1.000000 Sec/Pts

Punkte	0.0	0.1	0.2	0.3	0.4	0.5	0.6	0.7	0.8	0.9
442	05:42	05:42	05:42	05:42	05:42	05:43	05:43	05:43	05:43	05:43
443	05:43	05:43	05:43	05:43	05:43	05:44	05:44	05:44	05:44	05:44
444	05:44	05:44	05:44	05:44	05:44	05:45	05:45	05:45	05:45	05:45
445	05:45	05:45	05:45	05:45	05:45	05:46	05:46	05:46	05:46	05:46
446	05:46	05:46	05:46	05:46	05:46	05:47	05:47	05:47	05:47	05:47
447	05:47	05:47	05:47	05:47	05:47	05:48	05:48	05:48	05:48	05:48
448	05:48	05:48	05:48	05:48	05:48	05:49	05:49	05:49	05:49	05:49
449	05:49	05:49	05:49	05:49	05:49	05:50	05:50	05:50	05:50	05:50
450	05:50	05:50	05:50	05:50	05:50	05:51	05:51	05:51	05:51	05:51
451	05:51	05:51	05:51	05:51	05:51	05:52	05:52	05:52	05:52	05:52
452	05:52	05:52	05:52	05:52	05:52	05:53	05:53	05:53	05:53	05:53
453	05:53	05:53	05:53	05:53	05:53	05:54	05:54	05:54	05:54	05:54
454	05:54	05:54	05:54	05:54	05:54	05:55	05:55	05:55	05:55	05:55
455	05:55	05:55	05:55	05:55	05:55	05:56	05:56	05:56	05:56	05:56
456	05:56	05:56	05:56	05:56	05:56	05:57	05:57	05:57	05:57	05:57
457	05:57	05:57	05:57	05:57	05:57	05:58	05:58	05:58	05:58	05:58
458	05:58	05:58	05:58	05:58	05:58	05:59	05:59	05:59	05:59	05:59
459	05:59	05:59	05:59	05:59	05:59	06:00	06:00	06:00	06:00	06:00
460	06:00	06:00	06:00	06:00	06:00	06:01	06:01	06:01	06:01	06:01