

Coop FIS Cross-Country World Cup

Marketing Guide
2024/2025



Table of contents

1. Contacts

2. General marketing information

2.1 FIS Cross-Country World Cup Sponsors

2.2 Responsibilities FIS

2.3 Responsibilities FIS Media + Marketing

2.4 Responsibilities National Ski Associations (NSAs)

3. FIS Cross-Country World Cup venue

3.1 Start and finish area

3.1.1 Start

3.1.2 Finish

3.2 Advertising in stadium

3.3 Advertising on course

3.4 Event dressing

3.5 Ceremony wall

3.6 Leaderboard / interview backdrop

3.7 Leader Chair

3.8 Press conference backdrop

3.9 Video wall

4. Bib numbers

4.1 General information

4.2 Starting bibs

4.3 Leader bibs

4.4 Leg bibs

4.5 Athletes' training, Warm-up & Forerunner bibs

4.6 Service bibs

5. TV, Web and print material

5.1 Use of FIS Cross-Country World Cup logo

5.1.1 General guidelines for use of logo

5.1.2 Official FIS World Cup titles

5.2 FIS Cross-Country World Cup promotional material

5.2.1 Design guidelines

5.3 TV and Web

6. Hospitality

6.1 Accreditation

6.2 VIP tickets

7. Organizers checklist

7.1 Marketing material for NSA and FIS Sponsors

7.2 Requirements of FIS and FIS Media + Marketing

7.3 Technical infrastructure and power supply

7.4 Ideas for LOC websites

8. Application instructions

9. FIS Cross-Country World Cup production checklist

1. Contacts



FIS International Ski & Snowboard Federation

Blochstrasse 2
CH- 3653 Oberhofen
Tel.: + 41 33 244 61 61

Michal Lamplot

Race Director Cross-Country
Mob.: + 41 79 260 7573
@: lamplot@fis-ski.com

Simon Caprini

Assistant Race Director Cross-Country
Mob.: +33 659 435 694
@: simon.caprini@fis-ski.com

Doris Kallen

Cross-Country World Cup Coordinator
Mob.: + 41 79 425 21 02
@: kallen@fis-ski.com

Synne Dyrhaug

Media Coordinator Cross-Country
Mob.: +47 452 89 001
@: dyrhaug@fis-ski.com

Nordic Office

Office: +41 33 244 61 05
@: nordics@fis-ski.com

FIS Media + Marketing (FIS M+M)

Anna Stehl

Partnership Relations Manager Cross Country
Mob: + 49 176 6258 9541
@: stehl@fis-ski.com

Even Bjerck

FIS M+M Intern
Mob: +41 78 266 78 29
@: even.bjerck@fis-ski.com

Johannes Prein

Implementation Head Cross-Country
Mob.: + 43 664 356 1783

Andi Marugg

Senior Partnership Relations Manager
Mob.: +41 78 692 88 11
@: marugg@fis-ski.com



2. General marketing information

This Marketing Guide is in accordance with and a visualization of the existing advertising rules and is meant as a guideline to work with for the World Cup organizers. For further detailed information please see the FIS Advertising Rules, which can be found on the [FIS Website](#).

2.1 FIS Cross-Country World Cup Sponsors

- **Coop** is the official **FIS Title Sponsor** of the FIS Cross-Country World Cup.
- **Le Gruyère AOP** is the official **FIS Presenting Sponsor** of the FIS Cross-Country World Cup.
- **Certina** is the official **FIS Data & Timing Sponsor** of the FIS Cross-Country World Cup.

Branch Exclusivity of FIS Sponsors

All FIS sponsors have branch exclusivity within the following product categories:

- **COOP:** Retail for food, sports and building materials
- **Le Gruyère AOP:** Cheese
- **CERTINA:** (i) manufacturer and/or distributor and/or a retailer of and/or any other person, company or entity whose business is focused entirely or partially on watches (including smartwatches and wrist wearable devices with time displaying function), clocks, timepieces, timing devices, sports timekeeping, countdowns or scoreboards (hereinafter the “Product Category”) and/or other equipment which is directly or indirectly related to the Product Category or (ii) a provider of timekeeping services and/or of data handling and/or scoring and on-venue results systems, display services, including commentary information system, television graphics directly related to the timing and result data, and/or virtual television graphics services, associated with timekeeping/scoring systems and/or motion sensors, positioning systems and associated services such as installation, integration, testing, maintenance and operation (where such motion sensors, positioning systems and associated services relate to the official timekeeping and data handling services) except from SWISS TIMING LTD. And ST Sportservice GmbH or any third party, company or entity whose company name, trading name and/or associated trademark or logo or product is causing, or susceptible to cause, confusion with any of the products and/or services listed under points (i) and (ii) of this paragraph.

All these branch exclusivities apply for the whole event area in TV and non-TV relevant areas.

The NSA assures that no competitors are present with their branding in any commercial or public area of the event (inside and outside the TV-range). In case of any questions or uncertainties regarding exclusivities, please contact FIS M+M project manager.

Frequent Updates

Frequent updates between NSA and FIS M+M project manager are important. Keep FIS M+M project manager informed about local sponsor activities, open advertisement space that could be acquired, arising issues etc. FIS M+M project manager will contact NSA if FIS sponsors are planning on doing sponsorship activation on-site.

2.2 Responsibilities FIS

To define the advertising rules and guidelines for marketing and implementation of sponsor rights, FIS has an overview of all marketing related issues whereas at the event the FIS Race Director is the contact person.

2.3 Responsibilities FIS Media & Marketing

FIS M+M project manager will be your primary contact for marketing related questions during the preparation and implementation of the FIS Cross-Country World Cup event. During the FIS Cross-Country World Cup, FIS M+M will be present with a professional implementation team at each venue to implement the FIS sponsor rights.

2.4 Responsibilities National Ski Associations

NSA has to provide the necessary preparation of the sponsor area inside the TV-range in prior consultation with the FIS M+M project manager (banner fences, frames, posts, electricity, etc.). In addition, NSA is responsible for a clean appearance of the sponsors outside the TV-range, in accordance with FIS project manager. NSA is asked to provide assistance for the set up and dismantling of all advertising material on site one to two days before and after the event. In some cases, NSAs are asked to provide FIS M+M implementation team with basic wooden constructions for the installations. All information required will be communicated by FIS M+M project manager in due time before the season starts.

All advertising material set ups by NSA inside the TV-range must be according to the guidelines set forth in the [FIS Advertising Rules and Marketing Guide](#). In the event that the advertising material does not conform to these, FIS M+M reserves the right to undertake all the necessary amendments.

From arrival day until departure, please provide hotel rooms for FIS M+M project manager and implementation team in the FIS hotel at the preferred FIS rate. The hotel rooms shall be single rooms and include full board. In consultation with the FIS M+M project manager beforehand, half board in the hotel and lunch at the venue can also be an option. The exact number of rooms needed will be communicated before via FIS Online Entry System.

3. FIS Cross-Country World Cup venue

3.1 Start and finish area

Installations

NSA must use the official installations provided and installed by FIS M+M implementation team. NSA is responsible for assisting with the organization, set up and handling of all installations.

3.1.1 Start

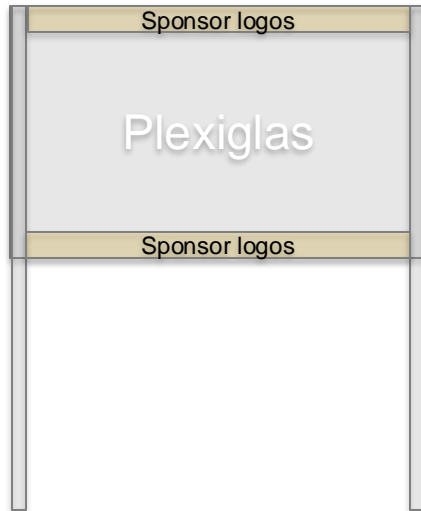

Sign-in Board (only for interval starts)

FIS M&M implementation team will provide the frame/installation for the sign-in boards for races with interval start. NSA shall provide the Plexiglas for the signatures. The Plexiglas with the signatures will be property of NSA. Additionally, sponsor bar stripes will be put on the sign-in boards with the sponsors on it.

Size of the Plexiglas needed: width 140cm x height 110cm x depth 1cm (1 per race, 2 in total for one interval race)

Please include FIS Sponsors on the sponsor bar stripes.

Size of sponsor bar stripes (stickers): width 140cm x height 10cm.



Please send the layout of the sponsor bar stripe to FIS for approval at least 10 days before production. Such approval is not to be unreasonably withheld.

FIS M+M Project Manager

Anna Stehl

Mob.: +49 176 6258 9541

@: stehl@fis-ski.com

INTERVAL START



The advertising space on the interval start installation is allocated as follows:

Start installation for interval start:

FIS Title Sponsor:	6 positions: 2 front, 2 back, 4 inside (69cm x 19.6 cm)
	2 positions: 1 front, 1 back (100cm x 28.5cm)
FIS Presenting Sponsor:	4 positions: 2 front, 2 back side (50cm x 25cm)
FIS Data/Timing Sponsor:	4 positions: 2 front, 2 back side (50cm x 10cm)
NSA Sponsor:	4 positions: 2 front, 2 back side (50cm x 25cm)
Resort logo:	4 positions: 2 front, 2 back side (75cm x 13.6cm)

Start installation for interval start

Start installations

All start installations will be provided and installed by FIS M+M implementation team.

The position at which this start installation shall be placed, will be determined by FIS M+M implementation team in consultation with the FIS Race Director.

Technical instructions and conditions

NSA is responsible for the production and provision of the stickers for the NSA Sponsor and the Resort logo. The costs for production are to be borne by NSA.

FIS M+M implementation team will inform you in due time, if electricity will be needed.

NSA Sponsor logo

Identification of the NSA sponsor, on both left and right sides

Recommended material:	Hard plates (e.g. forex)
Fixation:	Velcro (hook/scratchy side)
Dimension:	50cm x 25cm
Amount:	4 stickers

Resort logo

Recommended material:	Hard plates (e.g. forex)
Fixation:	Velcro (hook/scratchy side)
Dimension:	75cm x 13.6cm
Amount:	4 stickers

SPRINT START



front view (7 towers in a row)

The advertising space on the sprint start installations is allocated as follows:

Sprint starts: 7 towers, each three-sided

FIS Title Sponsor:	3 x 7 positions: 70cm x 20cm
FIS Presenting Sponsor:	3 x 7 positions: 42cm x 21cm
FIS Data/Timing Sponsor:	3 x 7 positions: 42cm x 10.5cm
NSA Sponsor:	3 x 7 positions: 42cm x 21cm
Resort logo:	3 x 7 positions: 75cm x 13.6cm



Start installations

All start installations will be provided and installed by FIS M+M implementation team.

The position at which this start installation shall be placed, will be determined by FIS M+M implementation team in consultation with the FIS Race Director.

Start installations for sprint start

Technical instructions and conditions

NSA is responsible for the production and provision of the stickers for the NSA Sponsor and the Resort logo. The costs for production are to be borne by NSA.

FIS M+M implementation team will inform you in due time, if electricity will be needed.

NSA Sponsor logo

Identification of the NSA sponsor, on both left and right sides

Recommended material:	Hard plates (e.g. forex)
Fixation:	Velcro (hook/scratchy side)
Dimension:	42cm x 21cm
Amount:	21 stickers

Resort logo

Recommended material:	Hard plates (e.g. forex)
Fixation:	Velcro (hook/scratchy side)
Dimension:	75cm x 13.6cm
Amount:	21 stickers

MASS START and PURSUIT START

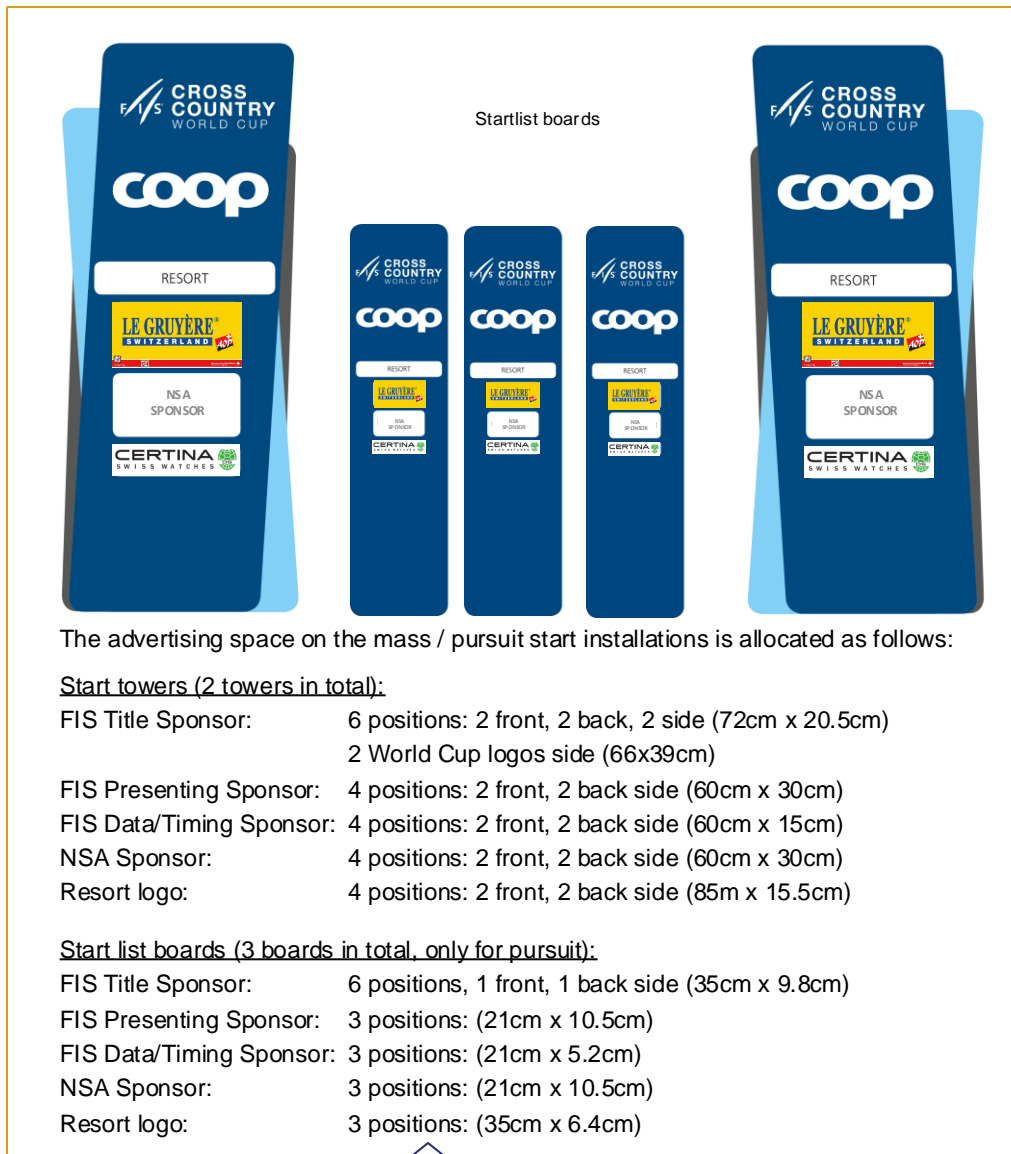

Start installation for mass start/pursuit
(start list boards for pursuit races only)

Start installations

All start installations will be provided and installed by FIS M+M implementation team.

The position at which this start installation shall be placed, will be determined by FIS M+M implementation team in consultation with the FIS Race Director.

Technical instructions and conditions

NSA is responsible for the production and provision of the stickers for the NSA Sponsor and the Resort logo. The costs for production are to be borne by the NSA.

FIS M+M implementation team will inform you in due time, if electricity will be needed.

NSA Sponsor logo

Identification of the NSA sponsor, on both left and right sides

Recommended material: Hard plates (e.g. forex)

Fixation: Velcro (hook/scratchy side)

Dimension: 60cm x 30cm

Amount: 4 stickers

Resort logo

Recommended material: Hard plates (e.g. forex)

Fixation: Velcro (hook/scratchy side)

Dimension: 85cm x 15.5cm

Amount: 4 stickers

Start List Boards

NSA Sponsor logo

Material: magnet foil

Fixation: magnetic

Dimension: 21cm x 10.5cm

Amount: 3 stickers

Resort logo

Material: magnet foil

Fixation: magnetic

Dimension: 35cm x 6.4cm

Amount: 3 stickers

Identification of the NSA sponsor, on both left and right sides

3.1.2 Finish

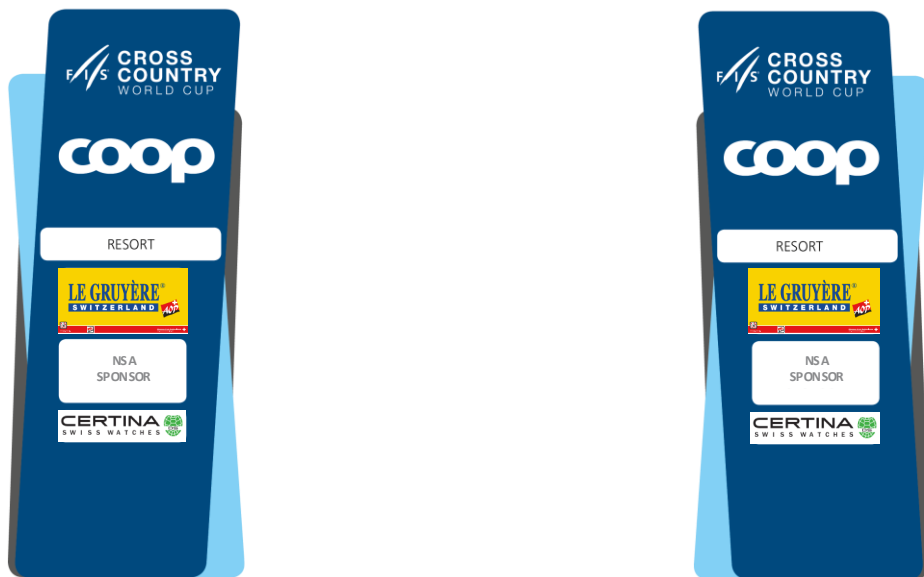

front view

The advertising space on the finish installations is allocated as follows:

Finish towers (2 towers in total):

- FIS Title Sponsor: 6 positions: 2 front, 2 back, 2 side (72cm x 20.5cm)
2 World Cup logos side (66 x 39cm)
- FIS Presenting Sponsor: 4 positions: 2 front, 2 back side (60cm x 30cm)
- FIS Data/Timing Sponsor: 4 positions: 2 front, 2 back side (60cm x 15cm)
- NSA Sponsor: 4 positions: 2 front, 2 back side (60cm x 30cm)
- Resort logo: 4 positions: 2 front, 2 back side (85m x 15.5cm)

Finish installations

Finish installation

The finish installation will be provided and installed by FIS M+M implementation team.

The position at which this finish installation shall be placed, will be determined by FIS M+M implementation team in consultation with the FIS Race Director.

Technical instructions and conditions

NSA is responsible for the production and provision of the stickers for the NSA Sponsor and the Resort logo. The costs for production are to be borne by the NSA.

FIS M+M implementation team will inform you in due time, if electricity will be needed.

NSA Sponsor logo

Identification of the NSA sponsor, on both left and right sides

- Recommended material: Hard plates (e.g. forex)
- Fixation: Velcro (hook/scratchy side)
- Dimension: 60cm x 30cm
- Amount: 4 stickers

Resort logo

- Recommended material: Hard plates (e.g. forex)
- Fixation: Velcro (hook/scratchy side)
- Dimension: 85cm x 15.5cm
- Amount: 4 stickers

3.1.2 Finish

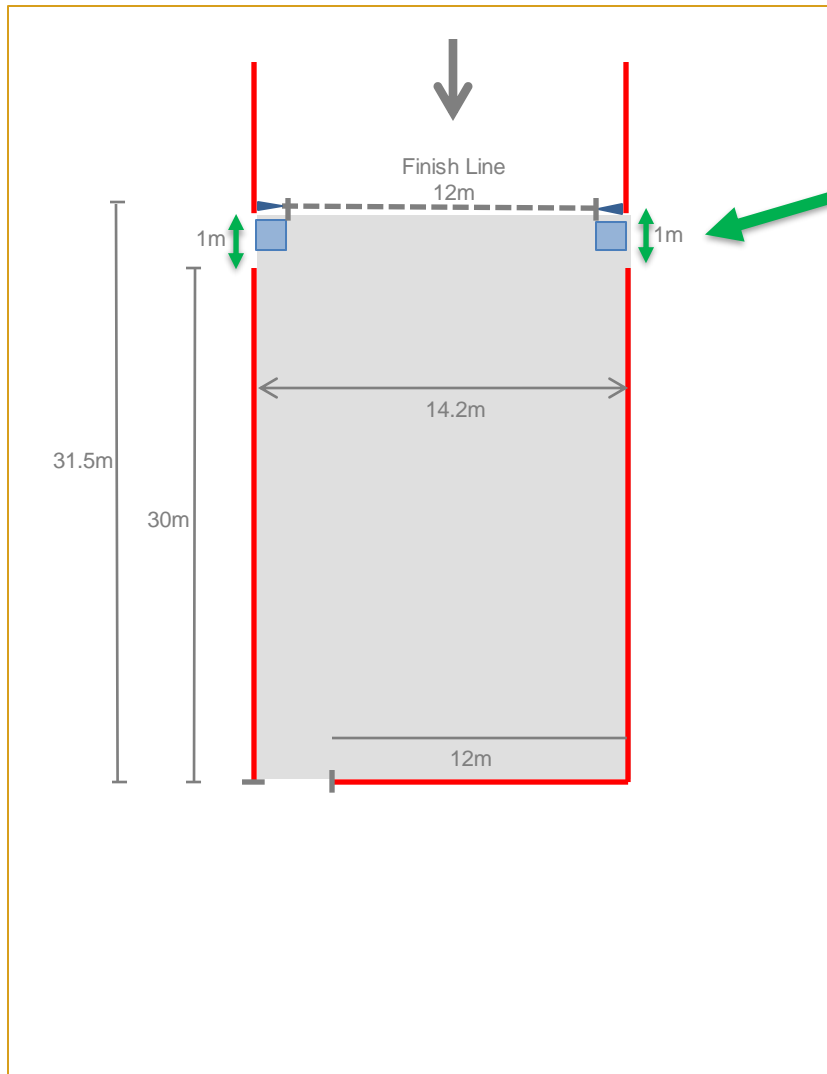

NEW: Please leave a 1m gap in the fence behind the finish installation. As we have new finish installations with the timing equipment integrated in the tower, the timing crew needs access to their devices from behind the towers. (see green arrows)

— Fence incl. platinum circle

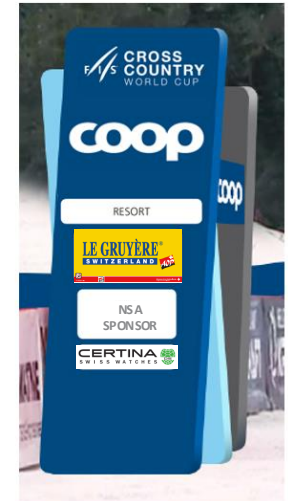

2.7m

1.10m

3.2 Advertising in stadium



Platinum Circle
(200cm x 25cm)

The banner positions in the stadium are allocated as follows:

FIS Title Sponsor: Platinum circle

NSA: All banners

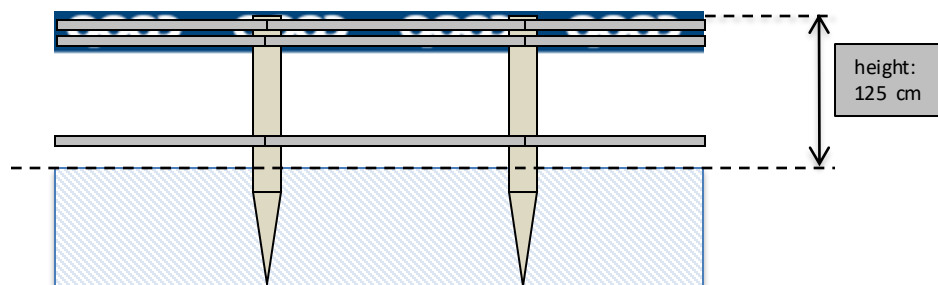

Platinum Circle

The platinum circle will be provided and installed by FIS M+M implementation team.

Please coordinate with FIS M+M project manager the areas where the platinum circle shall be installed.

Technical instructions and conditions

NSA is responsible for setting up a firm banner fence in the cross-country stadium. A full length firm wooden panel has to be installed on top of the stadium banners in order to affix the platinum circle.

The height of the platinum circle is 25cm. The banner fence therefore should have a minimum height of 125cm above snow level.

3.2 Advertising in stadium

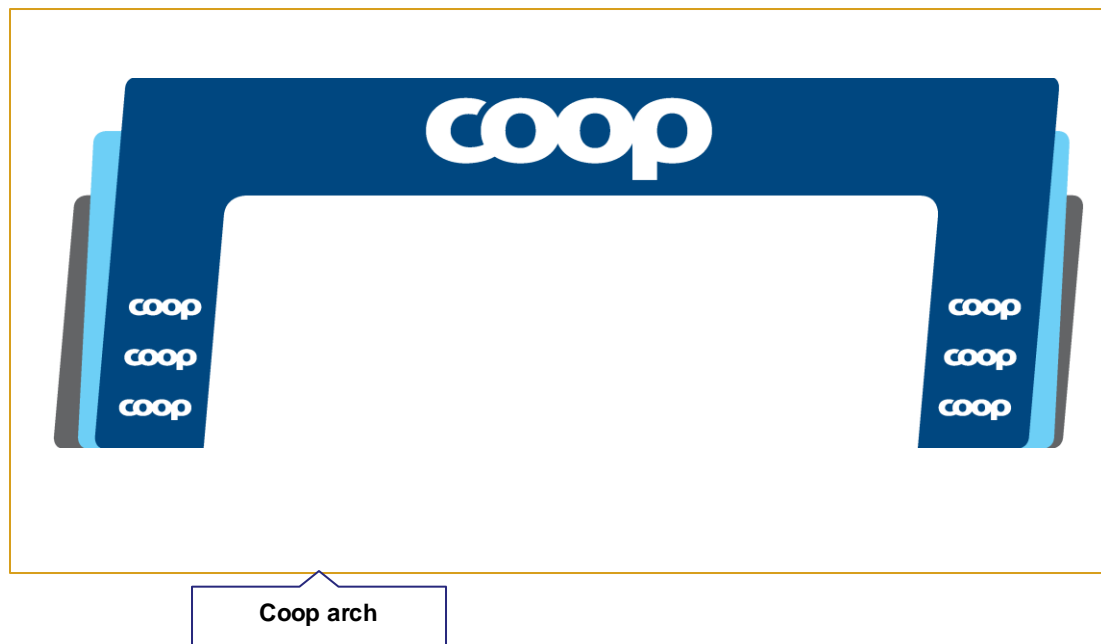

Coop arch big

Overall dimension: 16.8 x 5.2m

Internal dimension: 12 x 3.2m

Coop arch small

Overall dimension: 13 x 4.7m

Internal dimension: 9 x 3.2m

Usually, the big arch will be used.

The exact placement will be determined by NSA and FIS M+M project manager prior to the event.

The preferred position of the Coop arch shall be in the stadium (close to finish / home stretch), depending on available space and TV cameras.

The position of the Coop arch must be exclusive and cannot be shared with another sponsor.

Technical instructions and conditions

NSA shall have an electrical socket (220V) and a 5-meter extension cord ready at the arrival of the FIS M+M implementation team.

3.2 Advertising in stadium

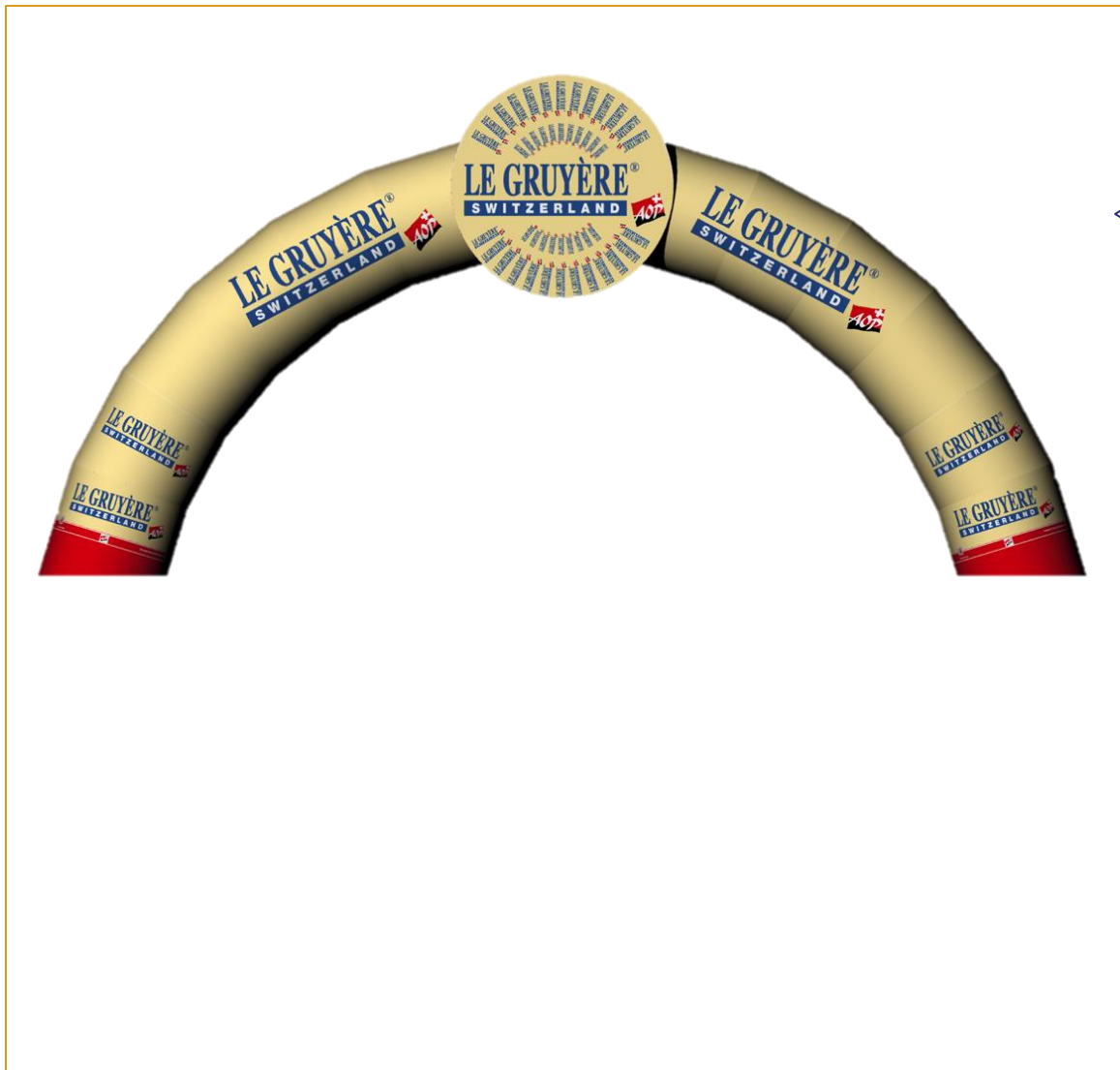

Le Gruyère AOP arch

Overall dimension: 15.6 x 4.6m

Internal dimension: 9 x 3.2m

Le Gruyère AOP arch

The FIS Presenting Sponsor has the right to place an inflatable arch.

The exact placement will be determined by NSA and FIS M+M project manager prior to the event, depending on available space and TV cameras.

The position of the Le Gruyère AOP arch must be exclusive and cannot be shared with another sponsor.

Technical instructions and conditions

NSA shall have an electrical socket (220V) and a 5-meter extension cord ready at the arrival of the FIS M+M implementation team.

3.2 Advertising in stadium



Ground markers

Ground markers in the design of the two FIS sponsors will be placed in the stadium to mark the cross-country slope. To mark the cross-country track on course, only neutral or NSA resort branded ground markers are allowed.

Distance markers

Coop or Le Gruyère AOP branded distance markers will be placed in the stadium to mark the distance to the finish line. Coop branded distance marker will be used on course to mark the distance to the intermediate timing position and Le Gruyère AOP branded distance marker will be used on course to mark the distance to the bonus position during mass start races.

Pit Stop boxes for Skiathlon and long-distance races:

NSA has to provide approximately 100 pit-stop boxes incl. numbers for Skiathlon and long-distance races. The branding right of the boxes belongs to NSA.

3.3 Advertising on course

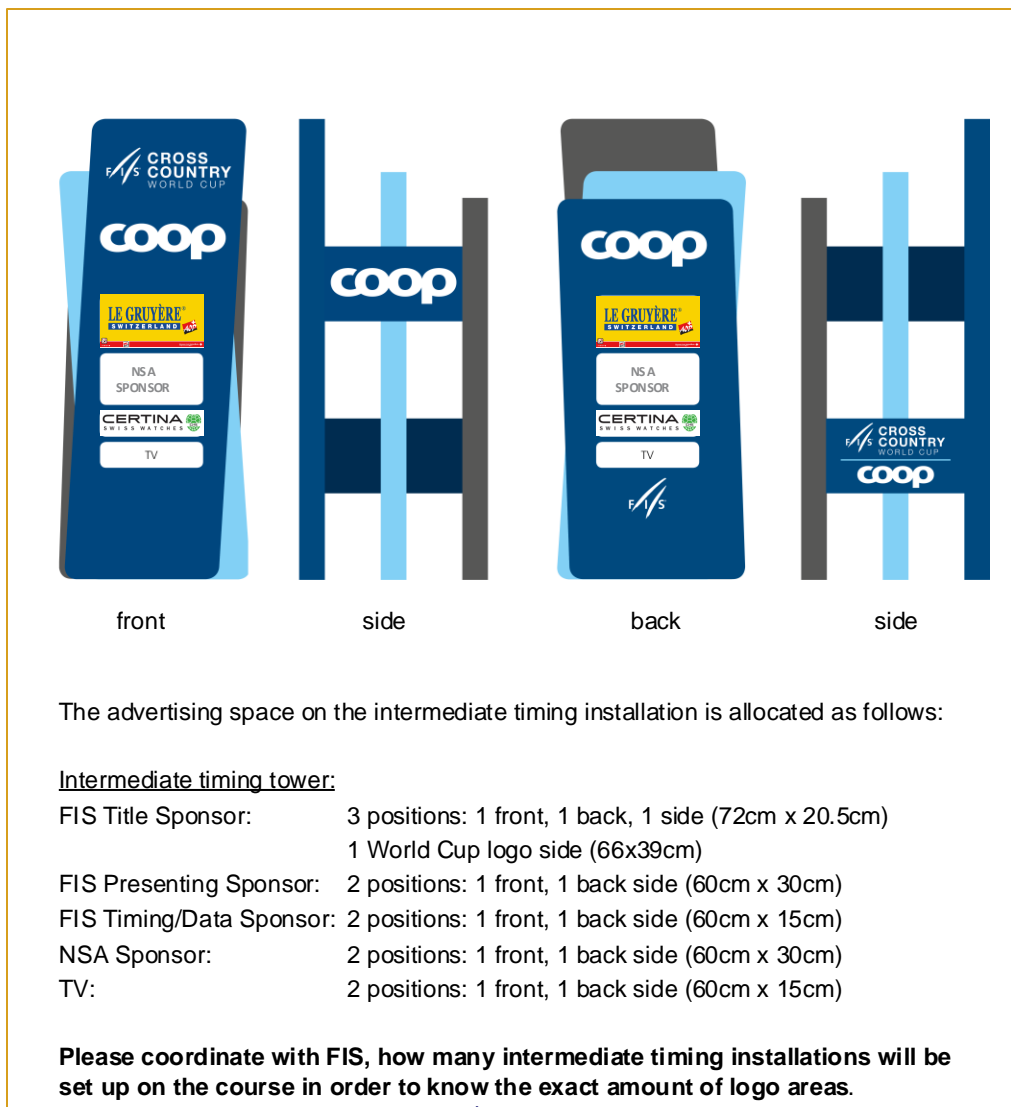

front

side

back

side

The advertising space on the intermediate timing installation is allocated as follows:

Intermediate timing tower:

- FIS Title Sponsor: 3 positions: 1 front, 1 back, 1 side (72cm x 20.5cm)
1 World Cup logo side (66x39cm)
- FIS Presenting Sponsor: 2 positions: 1 front, 1 back side (60cm x 30cm)
- FIS Timing/Data Sponsor: 2 positions: 1 front, 1 back side (60cm x 15cm)
- NSA Sponsor: 2 positions: 1 front, 1 back side (60cm x 30cm)
- TV: 2 positions: 1 front, 1 back side (60cm x 15cm)

Please coordinate with FIS, how many intermediate timing installations will be set up on the course in order to know the exact amount of logo areas.

Intermediate timing installation

Intermediate time installations

All intermediate time installations will be provided and installed by FIS M+M implementation team.

The position at which these intermediate timing installations shall be placed, will be determined by FIS M+M implementation team in consultation with the FIS Race Director.

Technical instructions and conditions

NSA is responsible for the production and provision of the stickers for the NSA Sponsor and the TV / Host broadcaster logo. The costs for production are to be borne by NSA.

FIS M+M implementation team will inform you in due time, if electricity will be needed.

NSA Sponsor logo

- Recommended material: Hard plates (e.g. forex)
- Fixation: Velcro (hook/scratchy side)
- Dimension: 60cm x 30cm
- Amount: 2 stickers per tower

TV/Host broadcaster logo

- Recommended material: Hard plates (e.g. forex)
- Fixation: Velcro (hook/scratchy side)
- Dimension: 60cm x 15cm
- Amount: 2 stickers per tower

3.3 Advertising on course

Advertising at intermediate timing points

Depending on the possible amount of banner positions due to space reasons, at intermediate timing points, the banner positions shall be split up based on the following rules:

- with 1 intermediate timing point on course: all possible banner positions are split up between FIS and NSA in good faith. If there is only 1 banner position available, the position will belong to FIS exclusively.
- with 2, 3 or more intermediate timing points on course: each intermediate timing point will be split up according to this rule:
 - 2 banner positions = 1x FIS, 1x NSA
 - 3 banner positions = 2x FIS, 1x NSA
 - 4 banner positions = 2x FIS, 2x NSA
 - 5 banner positions = 3x FIS, 2x NSA
 - etc.

The FIS Title Sponsor is always linked to the installation and placed closest of all sponsors to the installation. It is necessary, to have enough space between two different sponsor banners, from the cameras' point of view.

The NSA sponsor on the intermediate time installation must be the same sponsor as on the banners.

These rules shall not apply for intermediate timing positions in the stadium, as there are no specific banners around the installation.

All possible banner positions must be reflected from the camera shot and discussed in good faith between FIS M+M project manager and NSA prior to the event.

3.3 Advertising on course



Banners Coop



Banners Le Gruyère AOP

layouts may vary

The banner positions along the cross-country course are allocated as follows:

- FIS Title Sponsor: 2 (or 25% of) positions in TV relevant area
- FIS Presenting Sponsor: 1 (or 12.5% of) positions in TV relevant area
- NSA: 5 (or 62.5% of) positions in TV relevant area

sketch: wooden frame

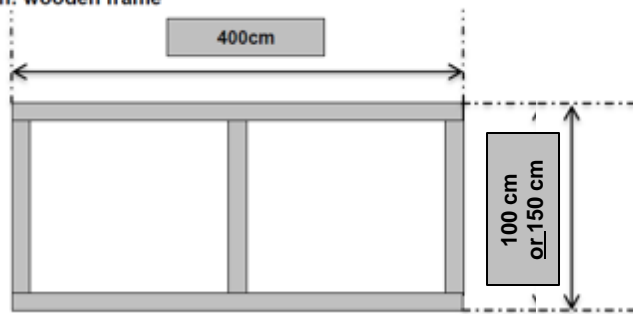

FIS M+M implementation team will provide and install all banners of the FIS Title Sponsor as well as the FIS Presenting Sponsor along the cross-country course.

In general, a “one shot policy” shall apply, meaning one sponsor per camera shot. For the advertising rules at intermediate timing points, please see page 21.

NSA has to provide FIS M+M project manager with a banner plan with detailed maps of all tracks incl. exact camera positions at least **1 month prior to the event**.

Technical instructions and conditions

NSA shall produce wooden banner frames for the banners on course before the FIS M+M implementation team arrives. Please put all needed wooden frames and posts on the agreed position on course.

The required number of wooden frames depends on the length of the course. Please contact FIS M+M project manager prior to the event.

Please also have enough extra wood (posts and latches) available and make sure that all posts are sharpened at one end.

3.3 Advertising on course

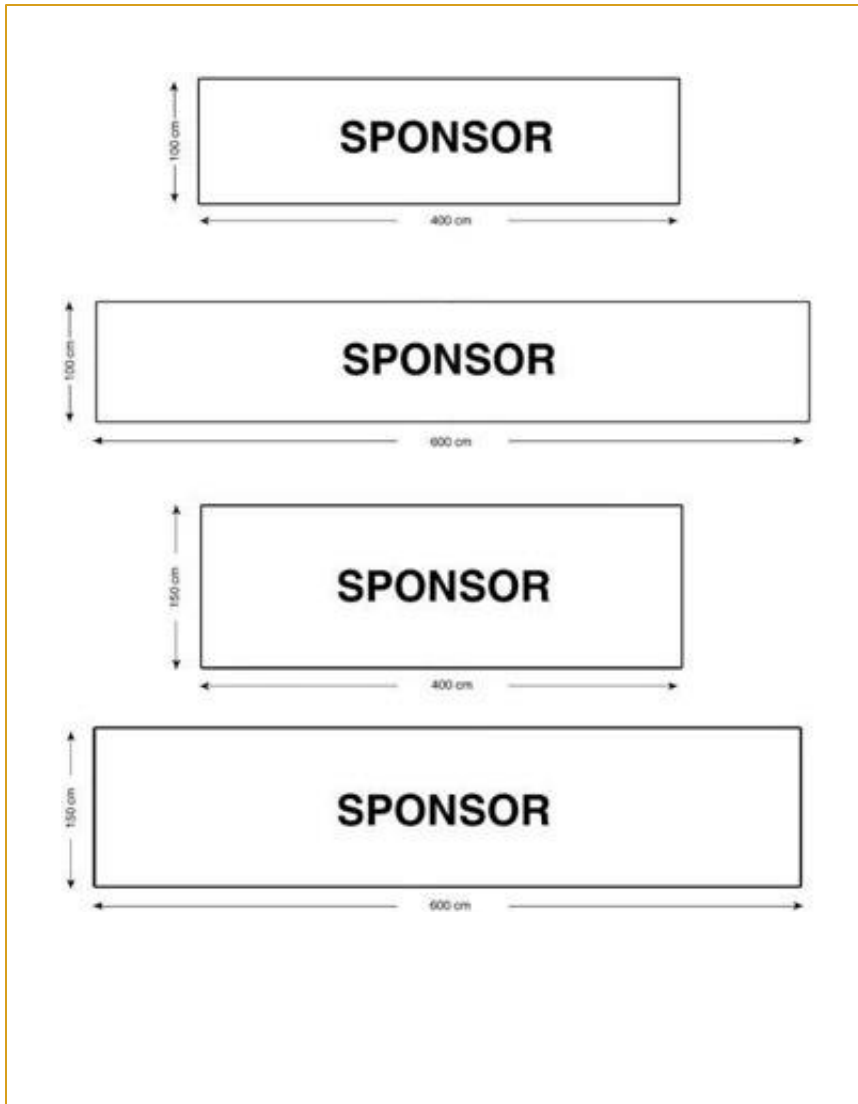

Banners on Course

The following banner sizes are allowed to use on course (depending on the position, individual solutions may be necessary). Please use only soft banners due to safety reasons. NSA is responsible for the production and implementation of NSA sponsor banners. The costs for production are to be borne by NSA.

- 400 x 100cm
- 600 x 100cm
- 400 x 150cm
- 600 x 150cm

3.3 Advertising on course



Bonus installation during mass start races

The bonus installation will be provided and installed by FIS M+M implementation team. NSA must use the official installation and distance markers.

The position at which this bonus installation shall be placed, will be determined by FIS M+M project manager in consultation with the FIS Race Director.

Advertising

Le Gruyère AOP has the right to place banners and distance markers at / around the bonus installation on course.

**Bonus installation (300 x 300 cm)
during mass start races,
incl. distance marker**

3.4 Event dressing

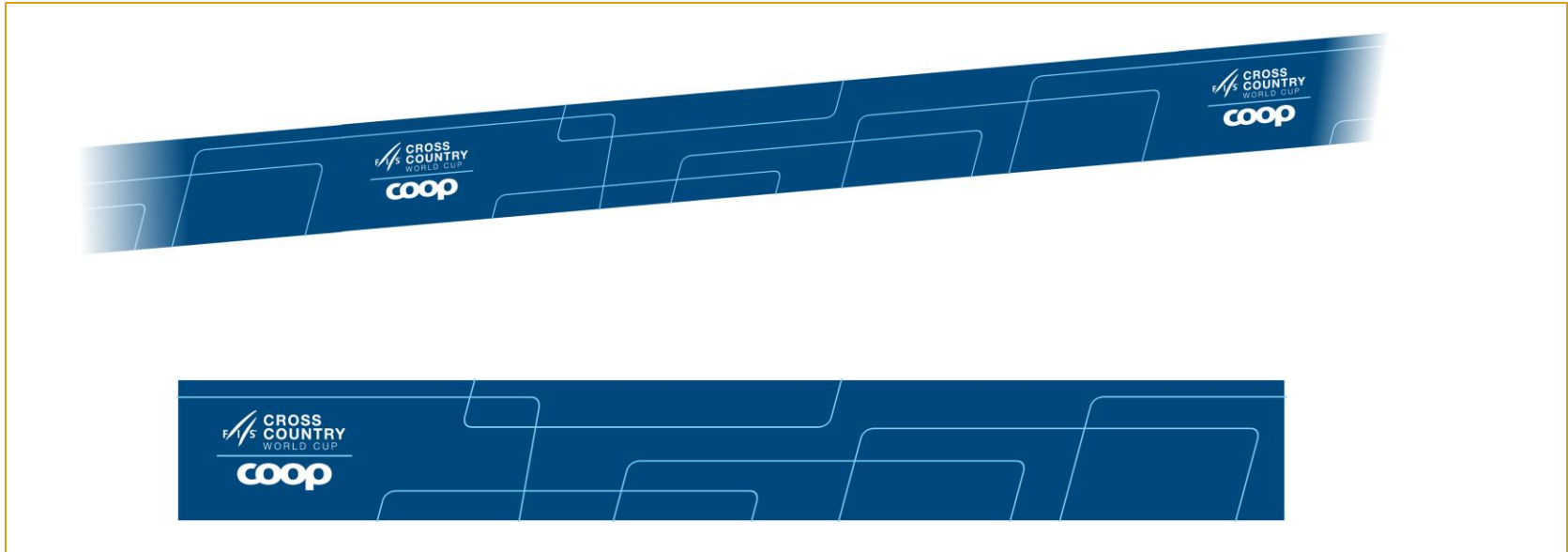

Endless banners

Event Dressing

FIS M+M will produce endless banners with the FIS Cross-Country World Cup logo and design. FIS M+M implementation team can provide NSA with a limited number of endless banners, to cover the mixed zone, the media and press conference centre, scaffolds (for TV cameras, seating etc.) and to cover up construction areas.

Please coordinate with FIS M+M project manager before the event, if you wish to use the endless banners at no extra cost.

3.5 Ceremony wall

Ceremony wall / podium

The wall and the podium for the award ceremony will be provided and installed by FIS M+M implementation team.

Placement

The placement of the wall and the podium shall be determined by the FIS Cross-Country World Cup Media Coordinator, the host broadcaster, FIS M+M implementation team and NSA based on the best possible TV exposure.

3.5 Ceremony wall



The advertising space on ceremony wall is allocated as follows:

Ceremony wall:

FIS Title Sponsor:	1 position: (100cm x 29cm) & 9 positions: (40cm x 20cm)
FIS Presenting Sponsor:	9 positions: (40cm x 20cm)
NSA Sponsor:	27 positions: (40cm x 20cm)
Resort logo:	1 position: (85cm x 15.5cm)

NSA can allocate the remaining 27 sponsor spaces according to their needs. Max. 6 different NSA sponsors can be shown on the wall.

**Ceremony wall
500x300cm**

Ceremony wall

The ceremony wall will be provided and installed by FIS M+M implementation team.

The placement of the wall and the podium shall be determined by the FIS Cross-Country World Cup Media Coordinator, the host broadcaster, FIS M+M implementation team and NSA based on the best possible TV exposure.

Technical instructions and conditions

NSA is responsible for the production and provision of the stickers for the NSA sponsors and the resort logo. The costs for production are to be borne by NSA.

Please coordinate with FIS M+M implementation team prior to the event, if an electrical socket (220V) will be needed at these positions.

NSA Sponsor logo

Recommended material:	Hard plates (e.g. forex)
Fixation:	Velcro (hook/scratchy side)
Dimension:	40cm x 20cm
Amount:	27 stickers

Resort logo

Recommended material:	Hard plates (e.g. forex)
Fixation:	Velcro (hook/scratchy side)
Dimension:	85cm x 15.5cm
Amount:	1 sticker

3.5 Ceremony wall



front view



Podium

The Podium will be produced and installed by FIS M+M implementation team.

3.6 Leaderboard / interview backdrop

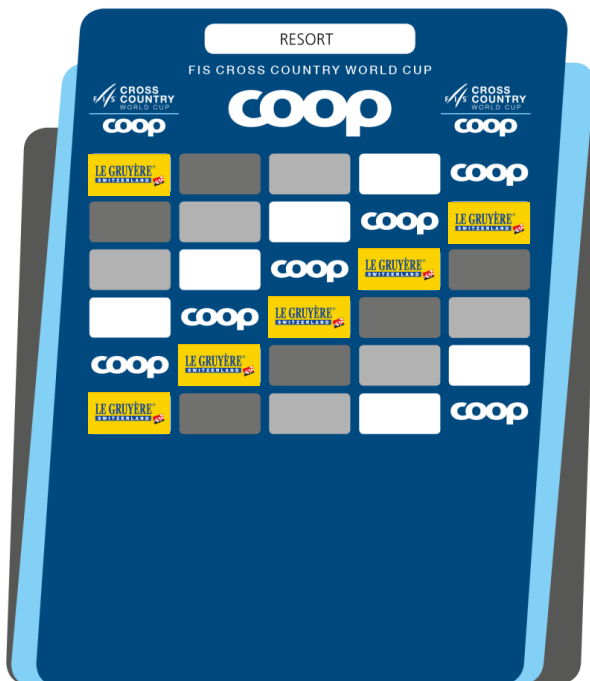

The advertising space on leaderboard / interview backdrop is allocated as follows:

Leaderboard / interview backdrop

FIS Title Sponsor:	1 position: (54cm x 15.5cm) & 6 positions: (27.2cm x 13.5cm)
FIS Presenting Sponsor:	6 positions: (27.2cm x 13.5cm)
NSA Sponsor:	18 positions: (27.2cm x 13.5cm)
Resort logo:	1 position: (70cm x 10cm)

NSA can allocate the remaining 18 sponsor spaces according to their needs. Max. 6 different NSA sponsors can be shown on the backdrop.

**Leaderboard / interview backdrop
198x225cm**

Leaderboard / interview backdrop

The leaderboard / interview backdrop will be provided and installed by FIS M+M implementation team.

This leaderboard / interview backdrop is used for the international flash interviews. It is placed in accordance with the FIS Cross-Country World Cup Media Coordinator, the host broadcaster and FIS M+M implementation team.

For interval starts, NSA must install a small stage in front of the backdrop, on which FIS M+M implementation team can set up the leaderboard / interview backdrop behind the leader chair.

Technical instructions and conditions

NSA is responsible for the production and provision of the stickers for the NSA sponsors and the resort logo. The costs for production are to be borne by NSA.

FIS M+M implementation team will inform you in due time, if electricity will be needed.

NSA Sponsor logo

Recommended material:	Hard plates (e.g. forex)
Fixation:	Velcro (hook/scratchy side)
Dimension:	27.2cm x 13.5cm
Amount:	18 stickers

Resort logo

Recommended material:	Hard plates (e.g. forex)
Fixation:	Velcro (hook/scratchy side)
Dimension:	70cm x 10cm
Amount:	1 sticker

3.7 Leader Chair

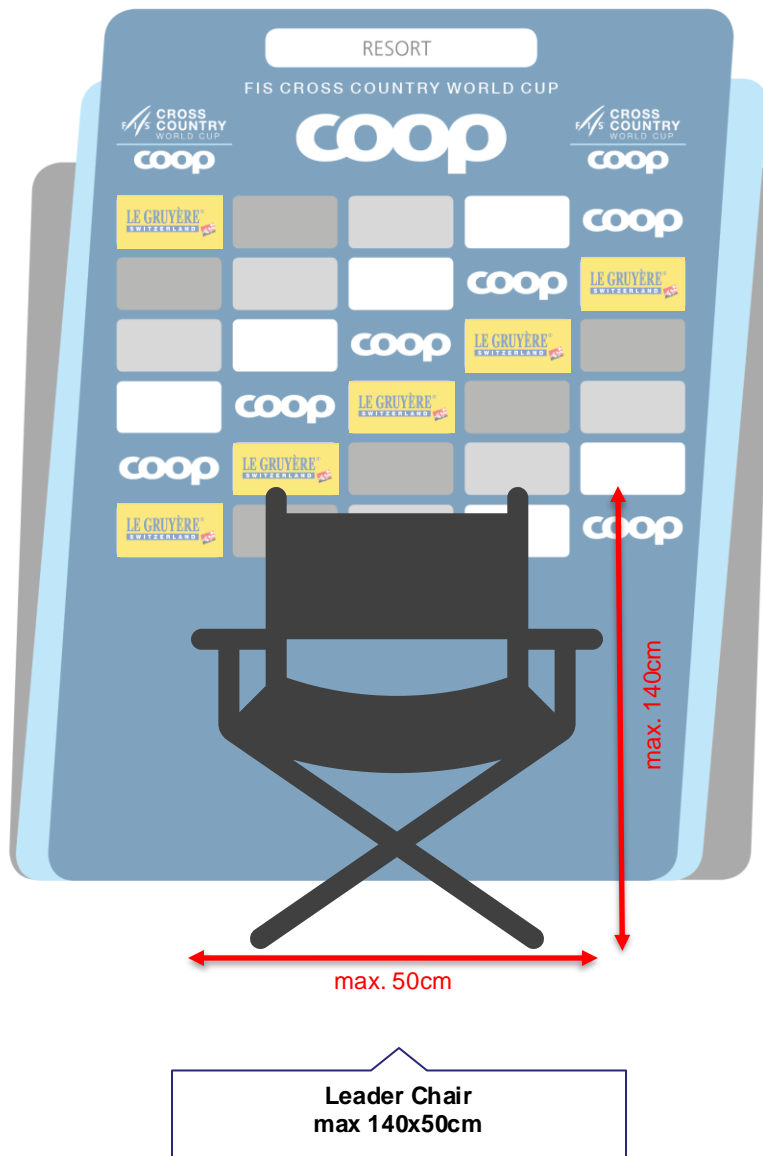

Leader Chair

The leader chair is positioned in front of the leader board (see previous slide).

Technical instructions and conditions

NSA is responsible for the production and provision of the leader chair. The costs for production are to be borne by NSA.

Dimensions and advertising space

Leader Chair

Dimensions: max. 140cm height x 50cm width

Logo/Brand Identification: max. 15cm height

It is granted to display one (1) logo and/or brand identification of an NSA / Event sponsor or the FIS Cup Series title / presenter on the leader chair.

3.7 Winner Presentation Banner

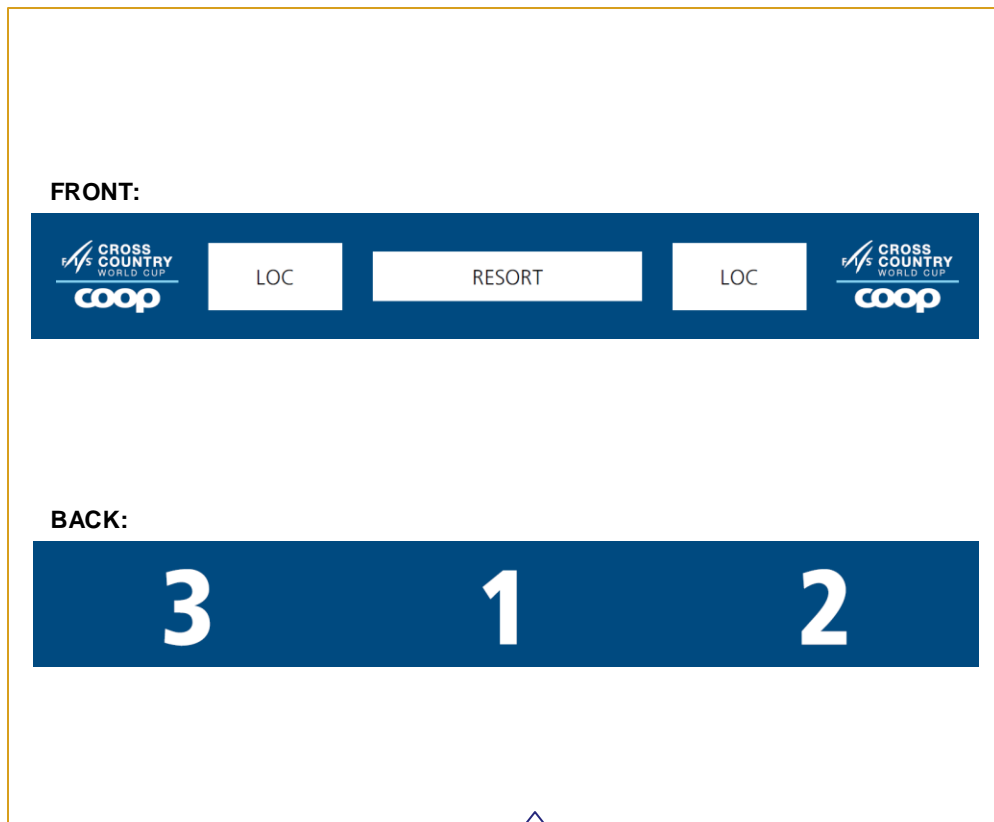

**Winner Presentation Banner
40 x 300cm (HxW)**

Winner Presentation Banner

The winner presentation banner will be provided and installed by FIS M+M implementation team.

This winner presentation banner may be used for the presentation of the top three athletes in the finish area before the official winner's presentation. It is placed in accordance with the FIS Cross-Country World Cup Media Coordinator, the host broadcaster and FIS M+M implementation team.

Technical instructions and conditions

NSA is responsible for the production and provision of the stickers for the NSA sponsors and the resort logo. The costs for production are to be borne by NSA.

NSA Sponsor logo

Recommended material: Hard plates (e.g. forex)
Fixation: Velcro (hook/scratchy side)
Dimension: 40 x 20cm (WxH)
Amount: 2 sticker
Logo Size: max. height of logo 15cm

Resort logo

Recommended material: Hard plates (e.g. forex)
Fixation: Velcro (hook/scratchy side)
Dimension: 85 x 15.5cm (WxH)
Amount: 1 sticker
Logo Size: max. height of logo 15cm

3.8 Press conference backdrop

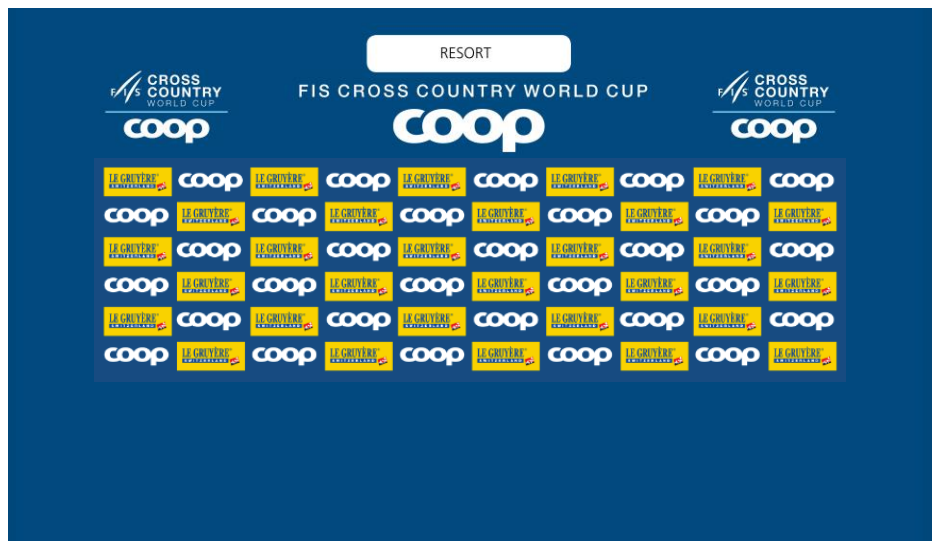

If NSA does not have its own backdrop, FIS M+M implementation team will provide one free of charge. On this backdrop the advertising spaces are divided between the FIS Title and Presenting Sponsor as shown in the graphic above.

FIS Title Sponsor: 1 position: (63cm x 18cm) &
 30 positions: (28cm x 12cm)
 FIS Presenting Sponsor: 30 positions: (28cm x 12cm)
 Resort Logo: 1 position: (85cm x 15.5cm)

If NSA uses the backdrop provided by FIS M+M, please make sure to provide a resort logo.

Press conference backdrop

NSA is allowed to use its own press backdrop as long as the FIS partners are correctly included. FIS M+M project manager needs to approve the layout of the backdrop in advance of the event. Otherwise, FIS M+M reserves the right to undertake the necessary amendments. The advertising space has to be allocated as follows:

FIS Title Sponsor: 20% of advertising space
 FIS Presenting Sponsor: 20% of advertising space
 NSA Sponsors: 40% of advertising space
 Resort: 20% of advertising space

NSA can allocate sponsor spaces according to their needs. Max. 6 different NSA sponsors can be shown on the backdrop.

Placement

The placement of the backdrop shall be determined by the FIS Media Coordinator.

Technical instructions and conditions

NSA is responsible for the production and provision of the Resort logo. The costs for production are to be borne by NSA.

Resort logo

Recommended material: Hard plates (e.g. forex)
 Fixation: Velcro (hook/scratchy side)
 Dimension: 85cm x 15.5cm
 Amount: 1 sticker

**Press conference backdrop
 370x224cm**

3.9 Video wall



Video wall

Advertising Spot on video wall

The FIS Title Sponsor (Coop), the FIS Presenting Sponsor (Le Gruyère AOP) and the FIS Data & Timing sponsor (CERTINA) each shall have the possibility to show a **30 second advertisement spot** on the video wall at the FIS Cross-Country World Cup event. Furthermore, FIS may provide promotional trailers for (non-commercial) FIS projects.

The advertisement spots of the sponsors shall be shown several times before, in between and after the races aired at least 3 times per event day.

Please communicate specifics about the necessary video spot format to FIS M+M project manager **30 days** prior to the event. FIS M+M will provide all spots.

FIS M+M Project Manager

Anna Stehl
Mob.: +49 176 6258 9541
@: stehl@fis-ski.com

4. Bib numbers

4.1 General information

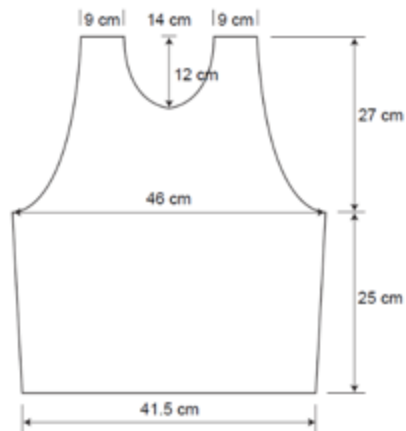

Cross-Country - Men

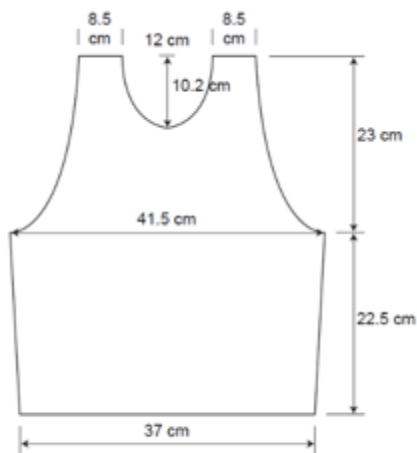

Cross-Country - Women

Advertising & Numbers

According to the [FIS Advertising Rules](#).

Assignment

According to the [FIS Specifications for CC SJ and NC Competiton Equipment](#).

Starting bibs must be assigned as follows and must be cut in such a way that the skier's shoulders are allowed free movement:

Women's size: without elastic band

Men's size: without elastic band

Fabric, material

T-shirt starting bibs in smooth material quality 100% Polyester / Interlock or 100% polyester knitwear (meshed or non – meshed)

Elasticity (stretch)

Meshed starting bibs: measured on a piece of fabric 10 cm wide:

Stretch ability in the width 18,5 cm

None meshed starting bibs: measured on a piece of fabric 10 cm wide:

Stretch ability in the width 24 cm

4.2 Starting bibs

Starting bibs

NSA is responsible for the production of all starting bibs for all cross-country competitions.

All bibs must be in conformity with the [FIS Advertising Rules](#) and colours and sizes as shown in the Marketing Guide. **Should this not be the case, neutral bibs without NSA sponsor provided by FIS M+M implementation team will be used without exception.**

Please send the layout of all bibs to FIS M+M project manager for approval at least **10 days before** production. Such approval is not to be unreasonably withheld.

Please find all templates here: [LINK](#)

FIS M+M project manager

Anna Stehl

Mob.: +49 176 6258 9541

@: stehl@fis-ski.com

4.2 Starting bibs

Please use the FIS100 logo on the left shoulder for all race bibs **until 31.12.2024**.
From 01.01.2025 on, please use the Mini World Cup logo on the shoulder for all race bibs as shown on the next page.

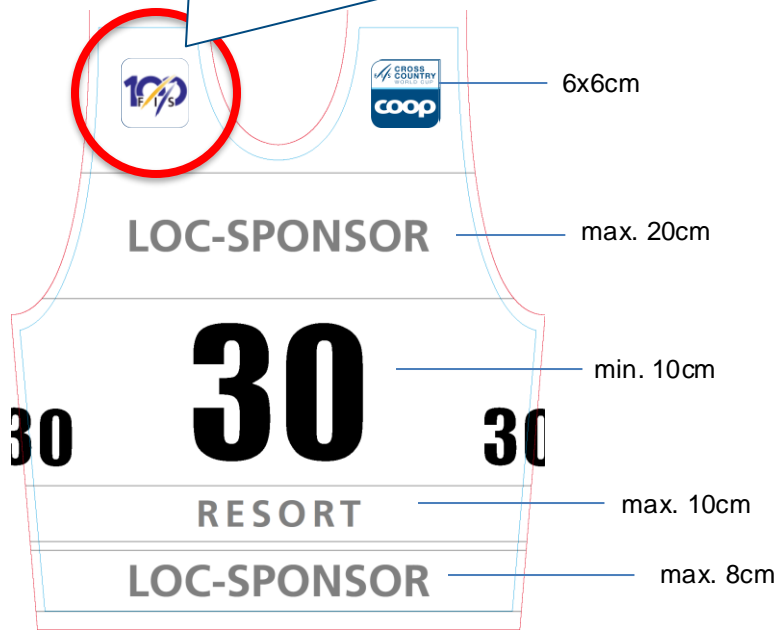

Starting bib Individual

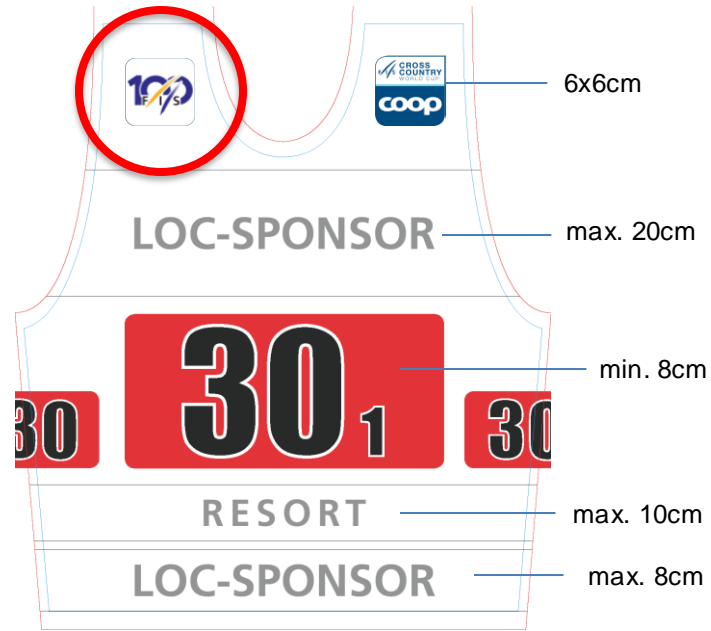

Starting bib Team

GPS Modules

If applicable, the costs for GPS module pockets in the race bibs are to be borne by the ordering party.

4.2 Starting bibs

Please use the FIS100 logo on the left shoulder for all race bibs **until 31.12.2024** as shown on the last page.

From 01.01.2025 on, please use the Mini World Cup logo on the left shoulder for all race bibs.

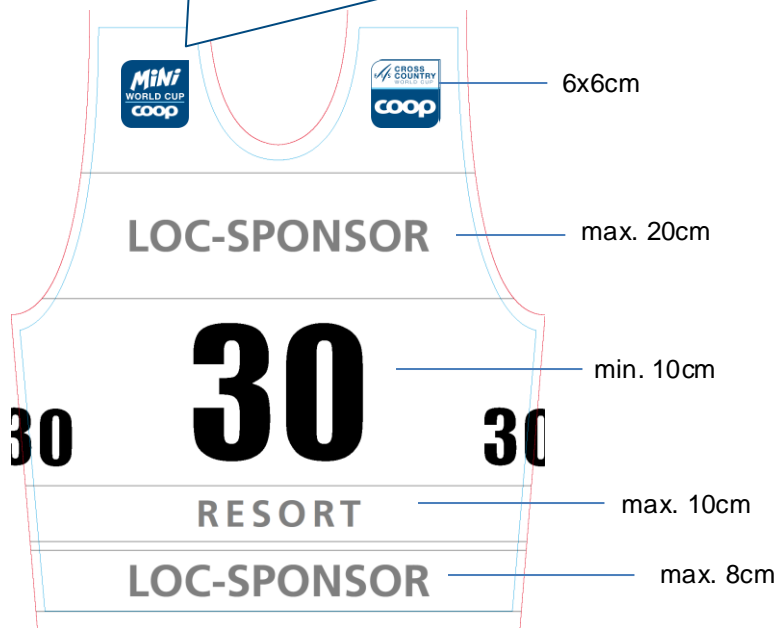

Starting bib Individual

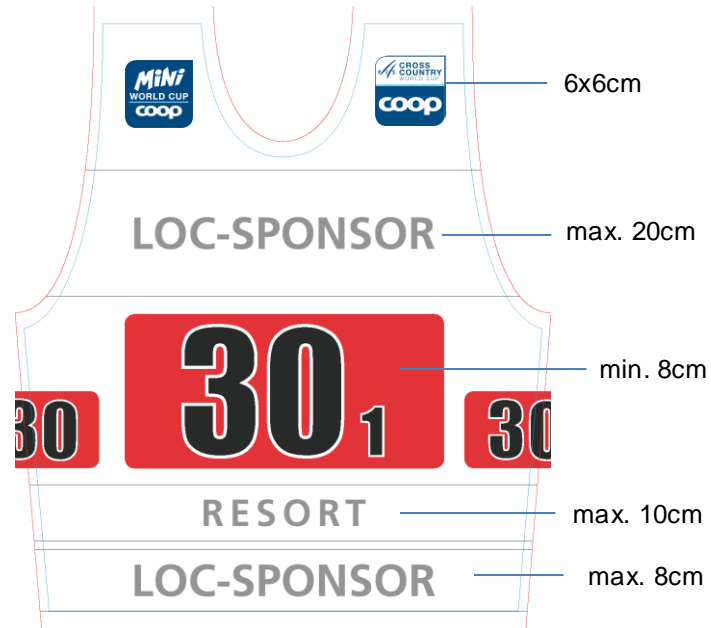

Starting bib Team

GPS Modules

If applicable, the costs for GPS module pockets in the race bibs are to be borne by the ordering party.

4.3 Leader bibs

LEADER BIBS TO BE PRODUCED (per race)

	Sprint Races	Distance Races	Team competitions (Team Sprint & Relay)
Yellow	2x (1x Quali + 1x Finals)	1x	-
Red	2x (1x Quali + 1x Finals)	1x	1 set for leading Nat. (Sprint 2 sets)
Green	2x (1x Quali + 1x Finals)	1x	-

VELCRO BIBS TO BE PRODUCED (per race)

	All individual competitions	Team competitions (Team Sprint & Relay)
Yellow	1x	-
Red	1x	1 set for leading Nation
Green	1x	-

Leader bibs

NSA is responsible for the production of the leader bibs for all cross-country competitions.

FIS M+M will provide the leader bib templates as shown on the next page.

All leader bibs must be in conformity with the [FIS Advertising Rules](#) and colours and sizes as shown in the Marketing Guide.

Should this not be the case, neutral leader bibs without NSA sponsor, provided by FIS M+M Implementation Team will be used without exception.

All leader bibs must be worn by the respective FIS World Cup leaders during the FIS World Cup event, as well as at the prize giving ceremony.

The leader of the overall FIS Cross-Country World Cup will wear a yellow leader bib and the leader per discipline will wear a red leader bib. Note, that the overall FIS Cross-Country World Cup leader has priority, which means, if the leader of a discipline is at the same time the overall FIS Cross-Country World Cup leader, he / she will wear the yellow leader bib for the overall FIS Cross-Country World Cup.

Velcro bib

For the prize giving ceremony, a special version of the leader bib with a velcro on the back must be produced by NSA. The velcro bib has to be handed out by NSA to the FIS Media Coordinator.

It has to be absolutely guaranteed that the correct velcro bib with the right sponsor logo is used for the respective ceremony.

Please send the layout of the leader bibs to FIS M+M project manager for approval at least **10 days before production**.

Such approval is not to be unreasonably withheld.

FIS M+M Project Manager

Anna Stehl

Mob.: +49 176 6258 9541

@: stehl@fis-ski.com

4.3 Leader bibs

Please use the FIS100 logo on the left shoulder for all race bibs **until 31.12.2024**.

From 01.01.2025 on, please use the Mini World Cup logo on the shoulder an all race bibs as shown on the next page.

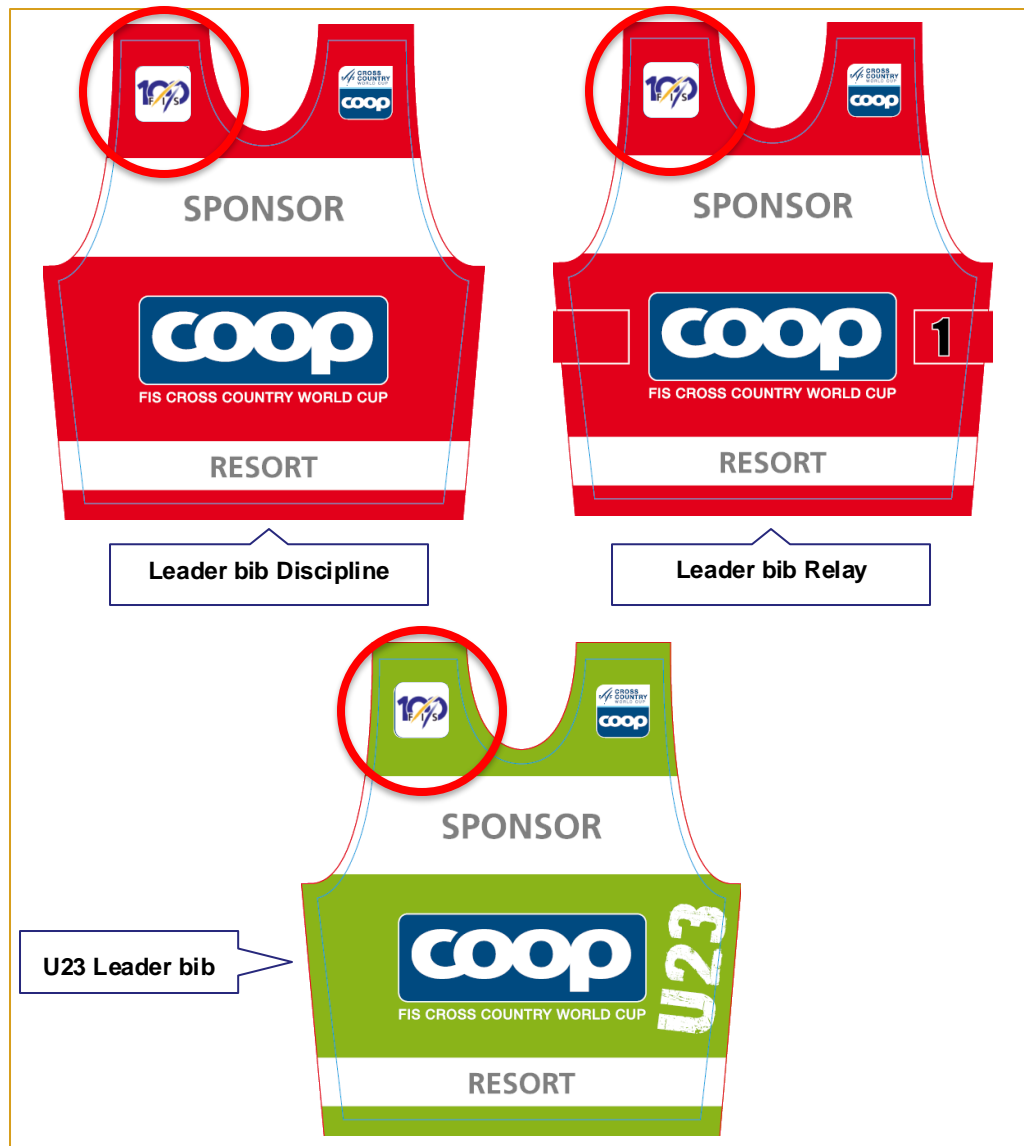
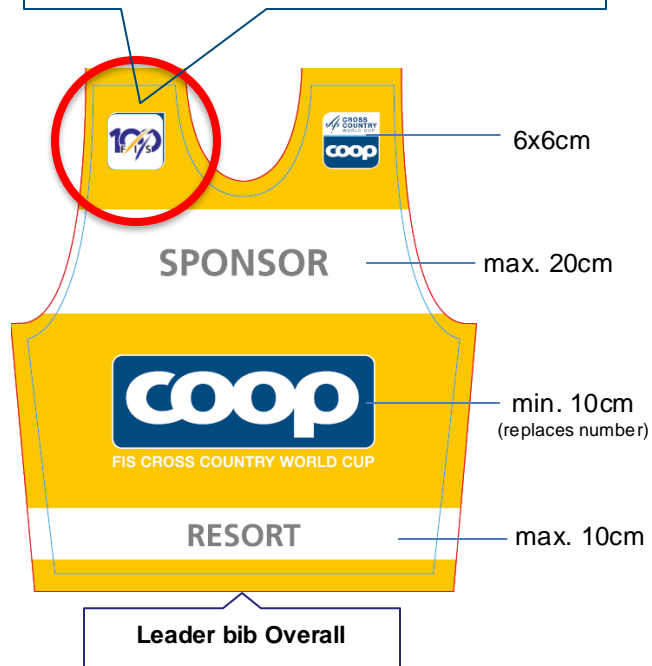

4.3 Leader bibs

Please use the FIS100 logo on the left shoulder for all race bibs **until 31.12.2024** as shown on the last page.

From 01.01.2025 on, please use the Mini World Cup logo on the left shoulder for all race bibs.

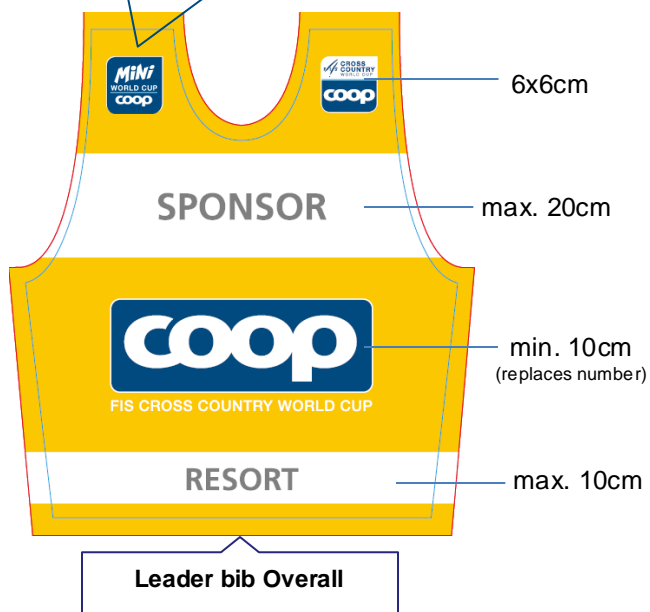

4.4 Leg bibs

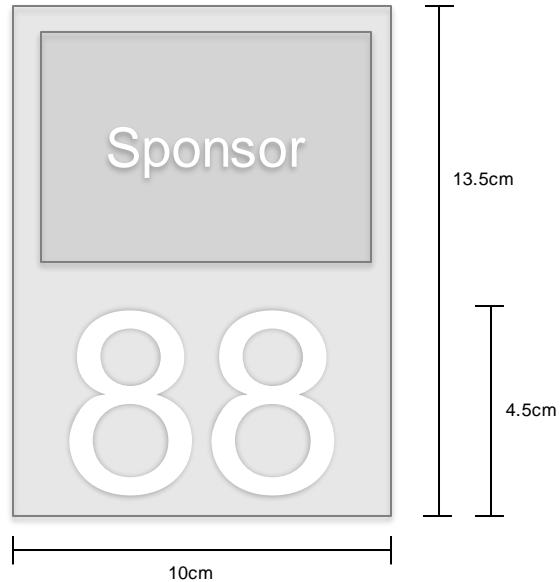

Example: Leg Bib



Leg bibs

Leg bibs need to be used during

- Mass starts
- Skiathlon
- Sprint Finals
- Pursuits
- Team Sprints (only 2nd athlete; the one that crosses the finish line)
- Relays (only 4th athlete; the one that crosses the finish line)

Each athlete has to wear a leg bib on the outside of each leg (2 leg bibs per athlete). The number on the leg bib has to match with the starting bib number.

Leg bibs must be self-sticking badges.

We recommend a size of 13.5x10cm. Whereas, the height of the number shall be minimum 4.5cm. Visibility will be lost, if a bigger badge will be used.

NSA is responsible for the production and provision of the leg bibs. The costs for production are to be borne by NSA.

4.5 Athletes' training & Forerunner bibs



Athlete Training bib
With or without NSA logos

Athletes' training bibs

Will be organized by FIS M+M.

If desired, a maximum of 4 different NSA sponsor logos can be allocated on 8 logo areas. One sponsor can be shown several times. The costs per bib will be split 50:50 between FIS title sponsor and NSA.

Forerunner bibs

NSA has to produce them on their own. Only event sponsors and / or the resort name / logo are allowed on it.

4.6 Service bibs



Course, Start/Finish, Staff bibs
With or without NSA logos

Course, Start/Finish, Staff

Will be organized by FIS M+M.

If desired, a maximum of 4 different NSA sponsor logos can be allocated on 8 logo areas. One sponsor can be shown several times. The costs per bib will be split 50:50 between FIS title sponsor and NSA.

4.6 Service bibs



Former **ENG & PHOTO** Bibs
until season 2022/23



Since 2023/24, the **ENG and PHOTO** Bibs have
been replaced by arm loops

“HBC”
= Host Broadcaster



“VIDEO”
= ex. ENG Bib



“PHOTO”
= ex. PHOTO Bib



HB, VIDEO & PHOTO arm loops

Coordinated and distributed by FIS Media Coordinator and NSA Media Coordinator. Please hand them back again to FIS M+M Implementation Team right after the event, ordered by number.

4.6 Service bibs

Jury, FIS, Course SRS, FIS Implementation Team, FIS Service, Sponsor

No further action needed with these bibs. Bibs will be distributed by FIS and FIS M+M Implementation Team.

LOC Service

LOC / NSA service persons at the cross-country course and in the start / finish area have to wear official bibs. If the NSA does not provide them on their own, FIS M+M Implementation Team can provide NSA with LOC Service bibs at no extra cost. Please contact FIS M+M project manager. Only event sponsors and / or the resort name / logo are allowed on it.

NSA is asked to make sure that all staff on site knows about the various bib categories as well as the respective access areas.

Bib Washing

Out of hygiene reasons, we recommend to wash the LOC Service bibs before handing them out to your volunteers. Please provide a responsible person that the FIS M+M Implementation team will call upon their arrival to hand over the LOC service bibs. The hand over of the bibs will take place against a deposit (see below).

The LOC Service bib shall be returned to the FIS M+M Implementation team as soon as possible after the last race. Once all bibs are back, the deposit will be returned.

Deposit System

Similar to the last seasons the deposit system will be continued.

The various boxes of bibs can be picked up at the FIS M+M Implementation Team storage and a deposit for every box needs to be paid.

To make things easier, we will charge the following amounts in each currency – please see in the table on the right.

Please inform your staff about this system and make sure they bring the deposit, when picking up the bibs. Please instruct them, that the bibs have to be returned to FIS M+M implementation team storage (and not stored in an office, placed somewhere else) and they will get back the deposit.

Please note: If not all bibs are returned to the FIS M+M Implementation Team, the whole amount of deposit will be kept by the FIS M+M Implementation Team for replacing the missing bib.

Deposit System - CC Bibs

1 box	PHOTO / VIDEO / HBC arm loops (each 1-50)
1 box	LOC Service bibs (1-80)

	per box		TOTAL*	
Estonia				
Finland				
France	50	EUR	100	EUR
Italy				
Norway	500	NOK	1000	NOK
Switzerland	50	CHF	100	CHF
Sweden	500	SEK	1000	SEK

5. TV, Web and print material

5.1 Use of FIS Cross-Country World Cup logo

a)



b)



The use of the official FIS Cross-Country World Cup logo is subject to a set of guidelines as outlined below. This logo is part of the corporate identity of the International Ski & Snowboard Federation (FIS). The FIS logo that it contains, as well as the abbreviation FIS and FIS Cross-Country World Cup are registered trademarks of FIS.

NSAs are not allowed to bring the official World Cup logo in connection with another sponsor than the FIS World Cup title sponsor, in any manner.

- a) **Positive logo (blue outline)**
- b) **Negative logo (white outline)**

There are two different versions of the FIS Cross-Country World Cup logo. The primary logo to be used is the positive logo. If the background is colored for some other graphical issues, the negative logo may be used.

The official FIS Cross-Country World Cup logo must be included in all tools designed for promotional purposes (posters, flyers, tickets, the internet etc.).

5.1.1 General guidelines for use of logo

Size

As a rule of thumb, the official FIS Cross-Country World Cup logo must cover 5% of the overall surface of any promotional tool it is placed on. In any case, the size of the logo may not be smaller than 30 mm (width for the portrait).

Logo Context, Frame, Position, Dimension







As a general rule, the official name and logo of the World Cup including the name of the FIS title sponsor and the name and logo of FIS shall appear at the top of the publication, with the other sponsors' and suppliers' names and logos appearing underneath or otherwise separated. The integrity of the official logo must be secured through appropriate context. The official logo may not be overshadowed by other word marks or logos. Similar but unrelated marks may not be used in the same context to avoid establishing an inappropriate relationship. In general use, the logo is with a frame and should be positioned horizontally. As a rule, the logo is two-dimensional.

Colors

As a principle, the logo should always be printed in color.

For one-color use, the black and white versions are available on request.

The colors are defined as follows

	COLOUR NAME	CMYK - PROCESS	RGB - SCREEN	SPOT OR SPECIAL COLOURS
	FIS YELLOW	C000 M035 Y100 K000	R240 G171 B000	Pantone 130C
	FIS BLUE	C100 M089 Y000 K000	R000 G035 B149	Pantone Reflex Blue
	COOP DARK BLUE	C100 M050 Y000 K040	R000 G073 B126	#00497E
	COOP LIGHT BLUE	C050 M000 Y000 K000	R130 G208 B245	#82D0F5
	COOP GREY	C000 M000 Y000 K075	R100 G100 B100	#646464
	BLACK	C000 M000 Y000 K100	R000 G000 B000	-

Typeface

FIS uses the typeface Frutiger in all printed matter. In corporate applications, the official FIS typeface is Arial.

5.1.2 Official FIS World Cup titles

English: Coop FIS Cross-Country World Cup

German: Coop FIS Langlauf Weltcup

French: Coop Coupe du Monde FIS de Ski de Fond

5.2 FIS Cross-Country World Cup promotional material

FIS M+M will provide NSA with templates for the FIS Cross-Country World Cup promotional material.

All event related promotional materials have to include the official FIS World Cup logo, the logos of the FIS Title Sponsor, the Presenting Sponsor and Data and Timing Sponsor and the name of the FIS website www.fis-ski.com. Event related promotional materials include, but are not limited to, posters, programs, start and result lists etc.

Please find all logos and templates here: [LINK](#)

Advertisement in Official Program

The FIS sponsors have the right to place a one-page advertisement DIN A 4, 4-color (or B/W in case of B/W program / result journal) in the official program / result journal for advertising purposes. Please communicate the size of the advertisement page in the official program to FIS M+M project manager **2 months before** the event.

Event Advertisement Material and Roll-Ups

If NSA is producing any event advertisement material or an event roll-up, the official FIS World Cup logo as well as the FIS Cross-Country World Cup sponsors have to be included.

Approval

All event related print materials must be sent to FIS M+M project manager a minimum of **10 days before production** for approval.

FIS M+M Project Manager

Anna Stehl
Mob.: +49 176 6258 9541
@: stehl@fis-ski.com

5.2.1 Design guidelines

Official poster

To provide a consistent appearance for the FIS Cross-Country World Cup in the promotional efforts world-wide, NSAs are required to use the official poster design. However, to cater for local needs, the design can be adjusted.

An example of the official poster can be found on the next page.

5.2.1 Design guidelines



Example of official World Cup poster

Cover pages for the official program and media / team guides

For reasons of consistency, FIS M+M also provides NSAs with templates for the design of the cover pages for the official program. As in the case of the official poster they can be customized.

Start and result lists

The top and bottom banners for the start and result lists will be delivered directly to the Timing and Data Service provider by FIS M+M.

Additional templates for further promotional materials can be made available on request.

5.2.1 Design guidelines

Accreditation card

The accreditation card is a personalized card which confers on its holder the right to take part in a World Cup Event. It establishes the identity of the card holder and specifies the access rights and other privileges of the card holder for a particular World Cup Event.

Since season 2010/2011, a FIS season accreditation card has been developed and will be issued to a selected group of individuals. This card will be valid at all FIS Cross-Country World Cup Events. All other individuals will need to apply for a local accreditation.

To ensure branding consistency across the FIS season accreditation card and the local accreditation card, each NSA will be provided with a template that is to be used to produce the local accreditation card. The design is similar to the FIS season accreditation card but with slight modifications to allow for needs of the NSA.

Specifications of the accreditation card

The dimensions of the accreditation card should be approximately: 12.5 x 9 cm. The card can be printed on cardboard / paper and laminated or produced directly as a plastic card.

The principal elements to be visible on the card are:

- The official FIS Cross-Country World Cup logo
- The official event logo
- The name of the event host and the date of the event
- A recent color photograph of the card holder (optional)
- Personal information about the card holder (name, function, responsible organization)
- Numerical codes (1 - 9) determining the zones to which the card holder is entitled to access. If NSA has access to additional areas, those can be added in this section
- Sponsor recognition through logos at the bottom of the card (front and back)
- Disclaimer

5.2.1 Design guidelines



FIS Season Accreditation Card

Process for design and approval of accreditation cards

Each NSA has to use the template provided by FIS M+M as basis for the design of the local accreditation card.

Where it is not possible to use the exact template provided by FIS M+M, NSA can develop their own layout but must work within the FIS guidelines. The photo on the card is optional.

Each NSA must present their accreditation card design to FIS M+M project manager for approval before the card is produced.

Local Accreditation Card

5.2.1 Design guidelines

Templates to be updated



- Team 1 (color: yellow)
- Limitation: according to size of the team
- Premium Parking - close to Team Service Village
- Free of charge



- Team 2 (color: red)
- Limitation: remaining team-related cars
- Parking close to Team and stadium
- Free of charge



- FIS Service (color: purple)
- FIS, STS; FIS Implementation Team
- Limitation: max. 15 Stickers
- Parking everywhere
- Free of charge



- TV compound (color: grey)
- Limitation: according to site inspection / space requirements
- Parking free of charge



- Media (color: green)
- Limitation: Parking Media
- Parking close to the Media Center
- Free of charge

Parking cards

FIS will print Cards for Team 1, Team 2 and FIS Service. NSAs are responsible for printing their own parking cards, using the templates from FIS M+M as well as the cards for Media and TV.

Each NSA has the right to print their resort name / logo on the designated white space (Arial, color: black, size: 30 pt).

In total, there are 5 different groups: Team 1, Team 2, FIS Service, TV, Media.

Please send your layouts to FIS M+M project manager a minimum of **10 days before printing** for approval.

Parking cards

5.3 TV and Web

TV Production and Organization

FIS, the respective NSA and its LOCs will undertake all possible steps together with the Host Broadcaster, respectively the TV rights holder, in order to reach a TV presence which will be as large as possible and to ensure top-quality production.

The NSA / LOC must contact FIS and the Host Broadcaster in due time, primarily about the camera positions and the places for advertising, as well as in regard to the program, the timing and the starting times.

The NSA, respectively the TV rights holder, is obliged to ensure that there is a live TV transmission in the country where the event takes places and that an international TV signal is made available.

5.3 TV and Web

FIS Title Sponsor



FIS Presenting Sponsor



Official Timekeeper



Event Sponsors



Local Organizer's Website

All FIS Cross-Country World Cup organizers are obliged to include the FIS Cross-Country World Cup logo on their website, as well as the FIS Sponsors' logos (Coop, Le Gruyère AOP, CERTINA).

To update your event site on the FIS Cross-Country website please contact Synne Dyrhaug at dyrhaug@fis-ski.com.

Logo Presentation

All logos (official World Cup logo and sponsors logos) have to be on a white background and must have the same size in relation to each other.

Please link the respective logos to the following website

- World Cup logo: www.fis-ski.com/cross-country
- Coop logo: www.coop.no
- Le Gruyère AOP logo: www.gruyere.com
- CERTINA logo: www.certina.com

6. Hospitality

6.1 Accreditation

Sponsors

If season accreditations are not valid, all sponsors shall receive LOC accreditations for their staff to access all necessary areas for fulfillment of their services, promotions and activities.

6.2 VIP tickets

FIS shall receive a total of 30 VIP tickets per event day to comply with the FIS Sponsors' contingents as stipulated in their respective sponsorship agreements.

The tickets get distributed by FIS M+M along to the FIS Sponsors.

In case that more than 30 tickets are needed for sponsors, FIS M+M will contact NSA/LOC to purchase additional tickets at preferable rates.

7. Organizers checklist

7.1 Marketing material for NSA and FIS Sponsors

Advertisement material	Size / material	Time	Status
Installations			
Start installation “Interval start” Produce 4 x NSA sponsor space Produce 4 x Resort logo space	50 x 25cm / hard plates recommended with Velcro on back 75 x 13.6cm / hard plates recommended with Velcro on back	Ready at arrival of FIS M+M implementation team	
Start installation “Sprint start” Produce 21 x NSA sponsor space Produce 21 x Resort logo space	42 x 21cm / hard plates recommended with Velcro on back 75 x 13.6cm / hard plates recommended with Velcro on back	Ready at arrival of FIS M+M implementation team	
Start installation “Mass start” Produce 4 x NSA sponsor space Produce 4 x Resort logo space	60 x 30cm / hard plates recommended with Velcro on back 85 x 15.5cm / hard plates recommended with Velcro on back	Ready at arrival of FIS M+M implementation team	
Startlist boards for pursuit races Produce 3 x NSA sponsor space Produce 3 x Resort logo space	21 x 10.5cm / magnetic foil (approved for outdoor conditions) 35x 6.4cm / magnetic foil (approved for outdoor conditions)	Ready at arrival of FIS M+M implementation team	
Finish installation Produce 4 x NSA sponsor space Produce 4 x Resort logo space	60 x 30cm / hard plates recommended with Velcro on back 85 x 15.5cm / hard plates recommended with Velcro on back	Ready at arrival of FIS M+M implementation team	
Intermediate Time installation Produce 2 x NSA sponsor space Produce 2 x TV / Host broadcaster logo space	60 x 30cm / hard plates recommended with Velcro on back 60 x 15cm / hard plates recommended with Velcro on back This amount only considers 1 Intermediate Timing installation. Please ask FIS about the exact amount of intermediate timing installations.	Ready at arrival of FIS M+M implementation team	
Ceremony wall Produce 27 x NSA sponsor spaces Produce 1 x resort logo space	40 x 20 cm / hard plate with Velcro on back 85 x 15.5 cm / hard plate with Velcro on back	Ready at arrival of FIS M+M implementation team	
Leaderboard / interview backdrop Produce 18 x NSA sponsor spaces Produce 1 x resort logo space	27.2 x 13.5 cm / hard plate with Velcro on back 70 x 10 cm / hard plate with Velcro on back	Ready at arrival of FIS M+M implementation team	
Press Conference Backdrop (FIS version) Produce 1 x resort logo space	85 x 15.5 cm / hard plate with Velcro on back	Ready at arrival of FIS M+M implementation team	
Winner Presentation Banner (Toblerone) Produce 2 x NSA sponsor spaces Produce 1 x resort logo space	40 x 20 cm / hard plate with Velcro on back 85 x 15.5 cm / hard plate with Velcro on back >> can be used from Ceremony Wall	Ready at arrival of FIS M+M implementation team	

7.1 Marketing material for NSA and FIS Sponsors

Advertisement material	Size/ material	Time	Status
COOP arch	Prepare electrical socket (220 V) and a 5m extension cord and 6 wooden euro pallets to sustain the arch	Ready at arrival of FIS M+M implementation team	
Le Gruyère AOP arch	Prepare electrical socket (220 V) and a 5m extension cord and 6 wooden euro pallets to sustain the arch	Ready at arrival of FIS M+M implementation team	
Starting bibs			
Send layouts to FIS M+M project manager for approval	PDF	10 days before production	
Leader bibs			
Send layouts to FIS M+M project manager for approval	PDF based on FIS template	10 days before production	
Leg bibs			
NSA is responsible to produce and distribute leg bibs			
Print material			
Send all event related print materials to FIS M+M project manager for approval	PDF	10 days before printing	
Communicate size of ad page for FIS sponsors in official program (if any) to FIS M+M project manager		2 months before printing of program	
Use FIS templates for accreditation and parking cards, send for approval to FIS M+M project manager		10 days before printing	
Video spots			
Communicate specifics about the necessary video spot format to FIS M+M project manager		2 months before event	
Leader chair			
Prepare a stage and leader chair for interval starts	Max size 140x50cm	Ready at arrival of FIS M+M implementation team	

7.2 Requirements of FIS

Requirements	Time	Status
VIP tickets (incl. Event tickets and top hospitality package)		
30 VIP tickets for FIS sponsors	FIS M+M will communicate all details to NSA/LOC prior to the event	
Accreditations		
If needed: For FIS sponsors' representatives	Amount and list with names will be communicated to NSA/LOC by FIS M+M prior to the event	
Support crew		
2 fit persons to help the FIS M+M implementation team	From arrival until departure of FIS M+M Implementation Team	
4 persons to handle the ceremony wall together with FIS M+M implementation team	10 minutes before each ceremony until end of ceremony	
FIS M+M implementation team		
3 big parking spots next to event venue 2 Trailers: parking spot close or next to container (8m length / 2,5m width / 3m height) 1 VW Crafter = bigger parking place close to venue 1 normal car (normally pulling the trailer) = normal parking place close to venue	Ready at arrival day until departure of FIS M+M implementation team	
If needed: overall accreditations (usually season accreditations are used)	Ready to be picked up at arrival of FIS M+M implementation team. Exact amount of accreditations needed will be communicated before	
Heated room/container close to stadium with electricity & internet connection, 1 table, 3 chairs	Ready at arrival day until departure of FIS M+M implementation team	
1 skidoo with trailer for the exclusive use of FIS M+M implementation team	Ready at arrival day until departure of FIS M+M implementation team	
Hotel rooms (single rooms with full board) for FIS M+M project manager and implementation team in the FIS hotel at the preferred FIS rate.	Arrival day until departure of FIS M+M implementation team. Exact amount of rooms needed will be communicated before via FIS Online Entry System.	

7.3 Technical infrastructure and power supply

Infrastructure & Supply	Placement	Time	Status
City Sprints			
12 heavy cement blocks or when underground is concrete in order to fix the arches on (min. weight 50kg)		Ready at arrival of FIS M+M implementation team	
Banner plan			
Set up a banner plan with all necessary information and send to FIS M+M project manager		2 months before event	
Wooden frames for banners			
According to the length of the course, prepare 4x1m and 4x1.5m wooden frames incl. posts and slats		Coordinate with FIS M+M project manager 2 months before. Ready at arrival of FIS M+M implementation team	

7.4 Ideas for LOC websites

Content	Comment	Status
General Information		
Maps & Profiles	Competition & training courses, points of interest (wax cabins, press centre, race office, entrances, grandstands...)	
Race Program	Competition program, side events	
Contact information	Race office, press centre, waxing area	
News Section		
Behind the scenes	Preparation, FAQ, information about the venue	
Tickets	Prices, points of sale, link to online shop	
Transport & Accommodation	Contact information, fares, schedules, pick-up and drop-off points, rental car offer, etc.	
Teams		
Team Invitation	PDF Version	
Team Captains Meeting	PDF Version	
Competition Information	Program changes, official trainings	
Important deadlines		
Link to entry system		
Media		
Media Invitation	PDF Version	
Download section	Logos, Pictures	
Opening Hours	Press and sub press centre, accreditation, race office, etc.	
Internet connection Information	Up- and Downstream , Wi-Fi, LAN, rates, networks	
Sponsors (mandatory)		
Official World Cup logo	With hyperlink to FIS Website	
FIS Sponsor logos	With hyperlink to Sponsors' websites.	

8. Application instructions

8 Application instructions



Velcro application on installations

The application of the resort stickers and NSA sponsor stickers on various installations is ensured by the usage of Velcro strips.

On the following slides, you can see the exact measurements for the fixation of the Velcro on the changeable stickers, in order to ensure an adequate fixation on the installations.

The soft side of the Velcro is affixed on the installation.

Example:

Overall measurement of sticker: 750mm x 136mm

The Velcro strip is fixed with a distance of 5mm inwards to the frame: 740mm x 126mm

The Velcro strip has a width of 20mm.

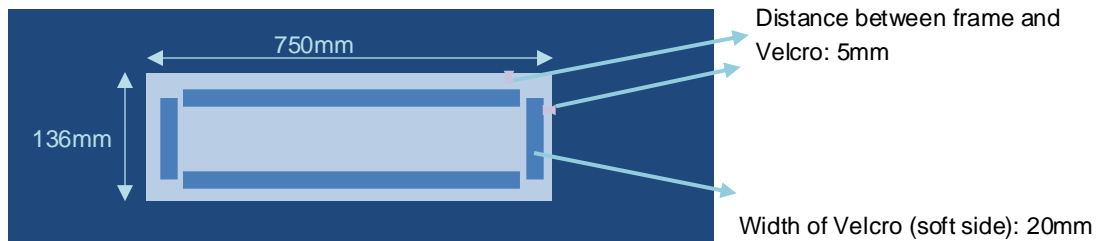

8 Application instructions



Velcro application on installations

The scratchy side of the Velcro shall be affixed on the back side of the changeable stickers.

Example:

Overall measurement of sticker: 750mm x 136mm

The Velcro strip must be fixed with a distance of 5mm inwards to the frame: 740mm x 126mm

The Velcro strip shall have a width of 30mm.

The Velcro strip can also be applied as a full rectangle on the backside of the sticker.

