

Timing Booklet

Alpine Para Alpine

Specifications, procedures and guidelines for timing in FIS Alpine and Para Alpine Skiing

Document

Timing Booklet Alpine, Para Alpine

Version

2.67

Date

2026-06-16

Author

FIS Timing Working Group

Table of Contents

1. FIS Alpine Timing Guide	4
1.1. References to race level classifications in Alpine:	4
1.2. References to race level classifications in Para Alpine:	5
1.3. Level notes	5
2. Equipment Set-Up (see drawing)	6
3. Timing Devices	8
4. Parallel Competition	10
5. Timing without Cable Connection between Start and Finish	12
6. Timing for Visual Impaired Para Competitions	14
7. Set-Up Diagram Level 0	15
8. Set-Up Diagram Level 1	16
9. Set-Up Diagram Level 2 (Cable)	17
10. Set-Up Diagram Level 3	18
11. Set-Up Diagram for Parallel Competitions Level 0 and 1	26
12. Set-Up Diagram for Parallel Competitions Level 2, 3 and 4	27
13. ICR 611 - Technical Installation	29
14. EET Calculation	32
14.1. EET Calculation - Example if System A and Backup Time has the Precision of 1/1000th	33
14.2. EET Calculation - Example if System A and Backup Time has the Precision of 1/10000th	34
14.3. EET Calculation - Example if Using a Hand Time with 1/100th	35
15. Timing & Data Technical Report Form	36
16. Criteria for FIS Approved Timing Devices for Alpine Ski Races	37
16.1. Timers	37
16.1.1. Timers with Permanent External Synchronisation	39
16.2. Start Gate	40
16.2.1. Para competitions	42

16.2.2. Technical Specifications for Start Gates:	43
16.3. Start Clock	45
16.4. Start Door	47
16.4.1. Startdoor Measurements	48
16.5. Photo Cell	50
16.5.1. Photo Cells for the Finish	51
16.5.2. Photo Cells for Intermediate Time	52
16.5.3. Technical Specifications for the Photo Cell	52
16.6. Photo Finish Systems	54
17. Homologation of Timing Equipment	56
17.1. List of Homologated Timing Equipment	56
18. Conclusion	57
19. Document Control	58
Sources Drawings	58
Version 2.60	58
Version 2.61	58
Version 2.62	59
Version 2.63	59
Version 2.64	59
Version 2.65	60
Version 2.66	60
Version 2.67	60
20. Appendix	61
20.1. Synchro setup diagrams	61

1. FIS Alpine Timing Guide

All timing devices used including start gates and photocells must be homologated as per the attached list. The most updated list can be found at the FIS website:

<https://www.fis-ski.com/DB/information/homologated-timing-equipment.html>

Races using devices not mentioned on that list will not be considered for FIS points.

1.1. References to race level classifications in Alpine:

Category	Description	Level
OWG	Olympic Winter Games	0
WSC	FIS World Ski Championships	0
WC	FIS World Cup	0
WQUA	World Cup Qualification	0
COM	World Cup Speed Event	0
ANC	Australian New Zealand Cup	1
EC	European Cup	1
ECOM	European Cup Speed Event	1
EQUA	European Cup Qualification	1
FEC	Far East Cup	1
NAC	Nor-Am Cup	1
SAC	South American Cup	1
UVS	Universiade	1
WJC	FIS Junior World Ski Championships	1
NC	National Championships	2
YOG	Youth Olympic Winter Games	3
AWG	Asian Winter Games	3
CISM	Military and Police	3
CIT	CIT Race	3
CITWC	CIT Race Arnold Lunn World Cup	3
FIS	FIS Race	3
FQUA	FIS Qualification	3
JUN	Junior Race	3
NJC	National Junior Championships	3
NJR	National Junior Race	3
UNI	University Race	3
EYOF	European Youth Olympic Festival	3
ENL	Entry League FIS races	4

1.2. References to race level classifications in Para Alpine:

Category	Description	Level
PWG	Paralympic Winter Games	0
PCOM	Paralympic Winter Games Speed Event	0
WSC	FIS World Ski Championships	0
WCOM	World Championships Speed Event	0
WC	FIS World Cup	0*
COM	World Cup Speed Event	0*
NCOM	North American Cup Speed Event	1**
UVS	Universiade	1**
SHC	Southern Hemisphere Cup	1**
SAC	South American Cup	1**
AC	Asian Cup	1**
NAC	Nor-Am Cup	1**
ECOM	European Cup Speed Event	1**
EC	European Cup	1**
COC	Continental Cup	1**
CCOM	Continental Cup Speed Event	1**
		1**
NC	Open National Championships	2***
FIS	FIS	3
ENL	Entry League FIS races	4

* Level 1 requirements of this timing booklet are permissible for this category, using level 0 when possible

** Level 2 requirements of this timing booklet are permissible for this category, using level 1 when possible

*** Level 3 requirements of this timing booklet are permissible for this category, using level 2 when possible

1.3. Level notes

Cabling of a higher category can also be used.

Example: Level 2 can use same cabling as Level 1 or 0.

2. Equipment Set-Up (see drawing)

Cable connection

For Level 3 and 4 competitions, timing without cable connection from the start is permitted for both A and B timing systems. Refer to set-up diagrams that describe in detail how this may be accomplished.

Attention: The cable dedicated to timing functions must be reserved for that purpose only and must be protected from any interference (e.g. speaker systems, snow gun data, etc.). No technical changes during the competition that may alter the transmission of trigger signals (length, capacitance, resistance, etc.) may be carried out.

The organiser must ensure that cable conduits and other cable runs do not interfere with timing cable functions. It is highly recommended that expert technical testing and verification of these timing cables be performed to assure timing cable integrity.

Start and Finish Start Gate

Minimum of 2 electronically isolated contacts to activate by 1 wand.

Timing wires ① & ② must be connected to separate start gate contacts using separate connectors. The wand must be installed so that starting is impossible without it opening.

Start Clock ⑩

Can show time of day, and countdown status, but must have acoustic signal. Must be synchronized with the other timing systems. Use of such a start clock is highly recommended for all DH/SG and GS disciplines and is mandatory for use at event Levels 2, 1 and 0.

Voice Communication ⑧

Timing impulse and voice communication functions can be separated on different wire pairs if manufacturer's specifications dictate.

If radios are used for voice communication, a dedicated channel must be used.

Timing Cables

Timing Cables Make sure that cables cannot be torn out at the start by a competitor, or by any other person next to the starting area.

Optical Cables: If a converter is necessary between timing cables and optical cables, then the converter must be approved by FIS.

Cells at intermediate time

Locate Cells carefully in co-ordination with the Technical Delegate and/or the Race Jury.

To avoid the cells being triggered by anyone other than the competitors, it is recommended that the person responsible for that intermediate timing point use a push-button to arm the photocells only when a competitor crosses the line.

Cells at the finish line ③ & ④

Please refer to the attached section that explains photocell use.

Wire must be used to connect photocells to the timer. Wireless is not allowed.

The use of a homologated timer with printer installed at the finish line directly attached to the photocells is recommended for Level 1 and Level 0 competitions or any time a lengthy wire connection to the finish area from the timing cabin is used.

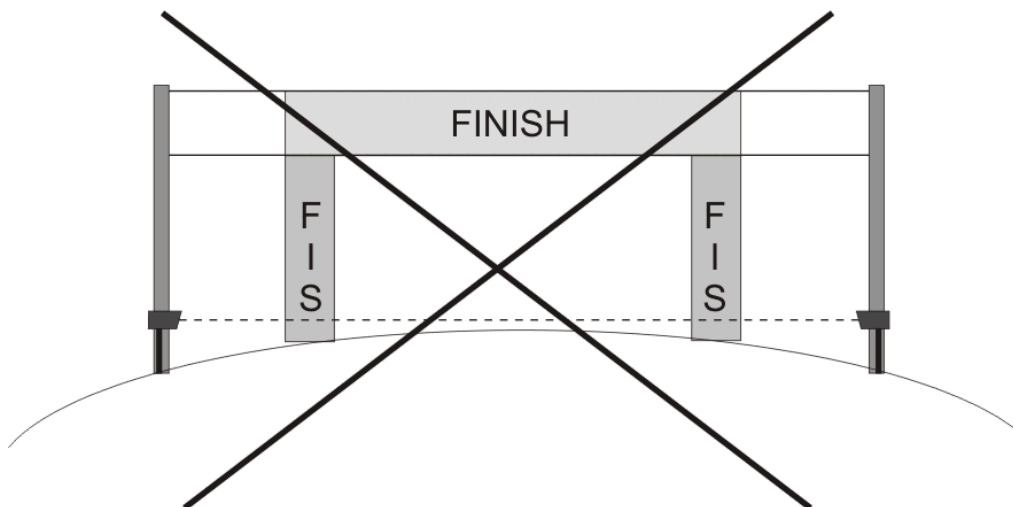
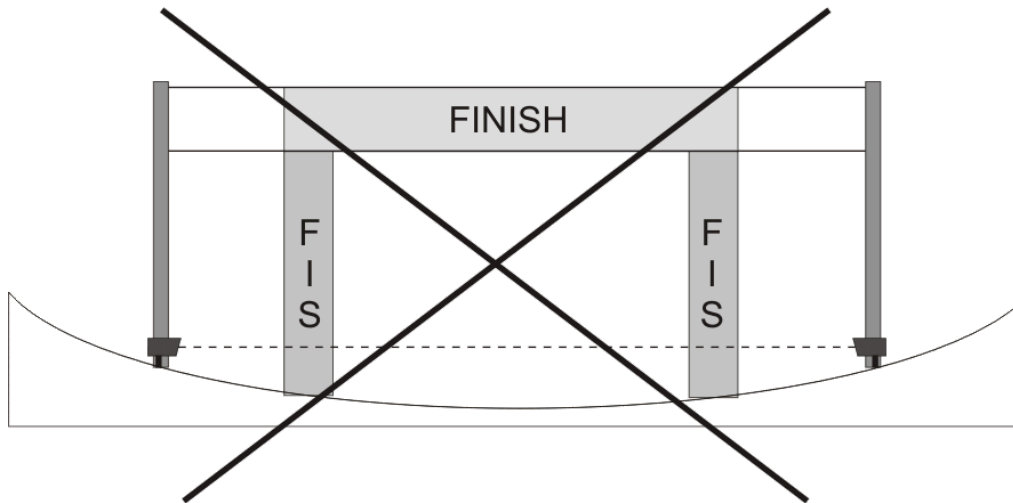
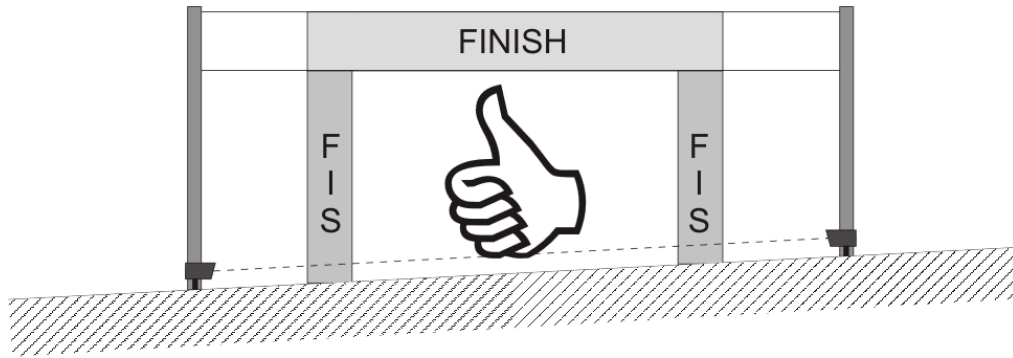

3. Timing Devices

System A Timer ⑤

Start line ① and finish cell ③ must be connected.

System B Timer ⑥

Start line ② and finish cell ④ must be connected.

The use of any electronic device (e.g. optocoupler and impulse distributors) between start gate and timer or photocell and timer must be specifically compatible and authorized by the manufacturers.

Homologated timers ⑨ must be used.

Manual hand timing ⑦

In all cases for all competitions at all levels, hand timing is mandatory. Stopwatches, with or without printers, showing times to at least 1/100th second should be synchronized to the time of day and used at the start and at the finish.

A complete list of hand times recorded at the start and the finish must be given to the chief of timing at the end of each run, or immediately upon request.

The manual hand timing must be done direct at the start line or finish line (direct sight to the start gate or finish line).

Photo Finish System

A photo finish system with synchronized time of day mode may be used for backup reasons at the finish line. A photo finish system is mandatory for Level 0 events.

Transponder Synchronisation

May not be used as official timing devices (for system A or B). Cannot be used as a substitute for Hand timing.

All elements of the timing installation must be installed and be in good working order at least one hour before the beginning of the competition. System A and B synchronisation to local Time of Day (ToD) must occur prior to the announced start of the 1st or only run and come from one single source impulse for all timing devices. One minute after synchronisation is done, an impulse must be sent by the same single source to check ToD synchronisation accuracy on Systems A and B. The maximum allowed difference between system A and B after one minute since initial synchronisation is 0.001 seconds. Discrepancies observed that are greater than 0.001 after one minute require the synchronisation to be redone and checked again prior to the start of the 1st or only run. Start Clocks, hand timing and any other timing devices must be synchronised with system A and B timers prior to the run.

Synchronisation of the timing systems must occur as close as possible to the scheduled start for the 1st or only run of the day. It is highly recommended this not be more than 30 minutes before the start.

Synchronisation of all systems must be maintained throughout each run. Timers must not be re-synchronised during any run.

Reference procedure diagrams annexed

Competition in progress

Reminders

In case of timing problems, the chief of timing must inform members of the jury or the finish referee immediately.

Starter and official timekeeper should agree upon using specific terms and commands during communication. This dialogue should be short and

precise, as well as systematically repeated for each competitor. In all cases it is recommended that the starter always informs the timekeeper(s) at the finish before and after a competitor leaves the start. At the end of each run or competition, before sending out the results, times and ranking from the timing systems and the computer results system must be compared and cross checked for accuracy.

Missed Time

A missed time is a time of day that is not shown on the printed tape of the system A timer. If a time from system B is missed but you have it printed on system A it is not considered as a missed time.

In case you have a missed time of system A and must replace it by time of day of system B or of a hand time, then you have to recalculate the missed time of day using ICR-rule 611.3.2.1.

Notes: At the end of the competition, it is compulsory to send electronically the “Timing & Data Technical Report Form” to FIS (see section [Timing & Data Technical Report Form](#) in this booklet). The printed tapes from the System A, System B and all hand timing records must be handed to the race organization keep it at least 3 months after the competition or after any appeal dealing with timing.

A member of the Timing Working Group could check at any time and at any race the timing system connection. A contact of each starting line and finish photocell must be available to connect a FIS timing device. Of course, such connection will be done at least 2 hours before the race or training start and not during the race or training.

4. Parallel Competition

Parallel competitions include parallel slalom, parallel GS and team events. At parallel competition two racers run down on two courses side by side.

As in Parallel Events two competitors race side by side; it is possible to measure either the difference in time (at Finish) or the individual run times (Start to Finish). If run times are measured the difference in time has to be calculated from the run times (in 1/100th seconds).

The TD has to announce at the Team Captain Meeting which timing method will be used.

Difference Time Calculated from Run Times	Red	Blue
Start Time	10:00:00.334	10:00:00.334
Finish Time	10:00:34.345	10:00:34.341
Calculated Run Time	00:00:34.011	00:00:34.007
Published Run Time	34.01	34.00
Difference Time	0.01	

Difference Time Calculated from Finish Times	Red	Blue
Finish Time	10:00:34.345	10:00:34.341
Calculated Difference Time	00:00:00.004	
Published Difference Time	0.00	

If a parallel competition has a second run (same competitors run against each other with changed course), it is possible to start the second run with the time difference of the first run (for level 0 races this is a must).

In the middle of the finish line between the two slopes only obstacles that are not higher than 40 cm are allowed.

For parallel competitions a photocell for each course is needed at the finish line. For level 0 and level 1 a system B photocell for each course is also mandatory.

For Level 0 a photo finish is mandatory. In case of a missing A or B time the time of the day of the photo finish can replace the A-time.

The photo finish time is taken when any part of the competitor's body crosses the finish line.

Example of Finish Setup:



Setup not allowed, sight in middle is blocked



very good setup

5. Timing without Cable Connection between Start and Finish

FIS Timing Working Group recognizes the importance of allowing emerging and technically responsible technologies to be used in modern FIS competitions. For this reason, and because of the flexibility that it affords, FIS Level 3 and 4 competitions may use timing solutions that do not require any hard wire connection between start and finish for either A and/or B systems. Level 2, 1 and 0 competitions are not allowed to use this solution, this could be only permitted in situations of force majeure.

The FIS does not homologate wireless timing technology for use in FIS skiing events. The FIS certifies timing equipment (timers, start gates, photocells, other devices) for use with hard-wired connections between start and finish locations as a general standard.

Regardless of the technology being used, every solution without hill cable must include the use of homologated timers operating in synchronized Time-of-Day with active printers or data memory. Systems will be represented by homologated timer(s) at the start and homologated timer(s) at the finish. Please refer to the set-up diagram that illustrates the correct use of this technique.

All timing rules remain in force in this situation (set-up, synchronisation, time-of day precision, printing, hand timing). In addition, for race results to be valid the TD must gather and submit to FIS all timer printer tapes or data memory with the Timing Technical Report Forms. The “no-wires” aspect of this technique provides the time-of-day start times and the time-of-day finish times from the separate, synchronized timing devices. In all cases the start and finish sensors must still be connected to the start and finish timers using hard-wire connections.

The Chief of Timing must make sure that all wireless solutions adopted work in the physical environment of the start and finish regardless of the weather conditions and temperature.

This allows race organisers to use many types of timing solutions without wires as long as these timers are in place and are used to verify the results.

If times are generated by a timing solution other than system A or B in all cases these times must be checked against system A and must match exactly. In case results deviate from system A, the competition must be evaluated on the A system times as per the normal timing set-up rules and procedures.

When a radio system with impulse transmission is used, the accuracy must be consistent within +/- 1/1000 second. The accuracy must be clearly described in the manual of the radio system. FIS rules must be applied, if a time from system B is used.

In practice the timing-without-wires solution must consider how to prove that times from all start and finish sensors are valid in the Time-of-Day ("ToD") methods normally used.

Thus, ANY additional wireless solution from ANY manufacturer that allows for comparison to these ToD start and finish times (recorded and preserved at each homologated timer) could be used. How the wireless transmission is achieved (impulse, data, GPS, Network, voice, paper) is open for use, but it must be able to match the ToD proof captured on the homologated devices at start and finish in ToD.

In all cases where no-wire solutions are used the timing tapes or data memory files must be sent with the results to the FIS. A description of techniques that demonstrate how the calibration issues between the time bases are dealt with over runs is also essential to be provided to FIS, since synchronisation could be an important element as evidence.

In all cases where wireless equipment will be used, it is highly recommended that Race Organisers or assigned FIS Technical Delegates check with a member of the FIS Timing Working Group in advance of the competition to describe the intended wireless equipment set-up and to verify test data.

Please refer to the set-up diagram that illustrates the correct use of this technique.

6. Timing for Visual Impaired Para Competitions

In visually impaired para competitions, the guide should cross the finish line before the athlete, in accordance with competition rules. Timing must be recorded on the athlete's finish, not the guide's. In most cases, two distinct impulses will be observed at the finish line, the first corresponding to the guide and the second to the athlete; timing systems must ensure that the valid time is taken from the second impulse. However, near the finish the guide and the athlete have sometimes been observed crossing the line together, in which case the two impulses may not be clearly distinguishable.

For this reason, the preferred setup is a photofinish camera, which reliably identifies the athlete's finish. When a photofinish camera is not available should alternative means be used: a hand timing pushbutton should be used to open the main timing line to manually capture the athlete's crossing rather than the guide's, while the second line must remain permanently open to record both impulses. Result outputs must reflect the athlete's finish time only.

7. Set-Up Diagram Level 0

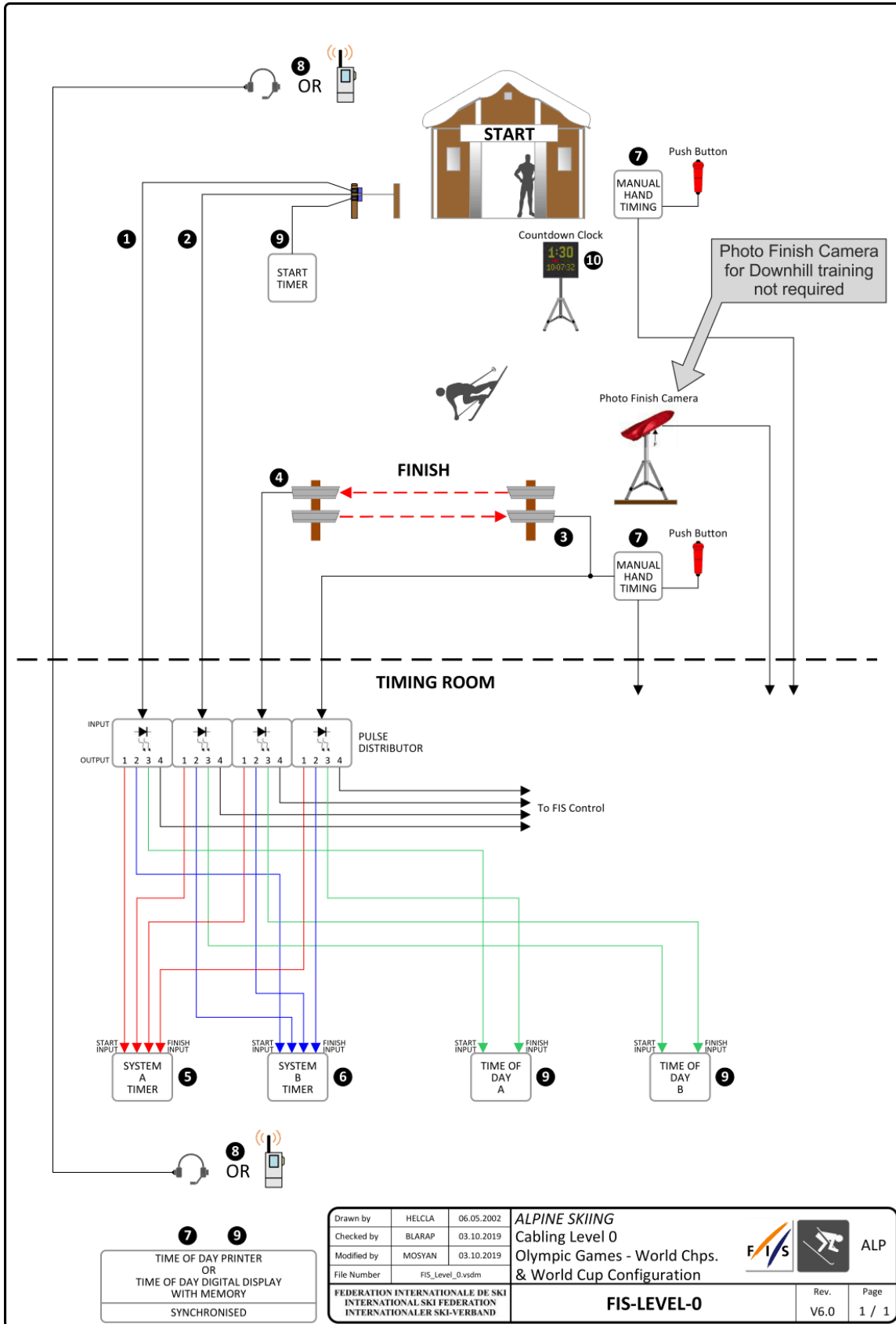

Drawn by	HELCLA	06.05.2002	ALPINE SKIING Cabling Level 0 Olympic Games - World Chps. & World Cup Configuration	
Checked by	BLARAP	03.10.2019		
Modified by	MOSYAN	03.10.2019		
File Number	FIS_Level_0.vsdm		FIS-LEVEL-0	Rev. V6.0 Page 1 / 1
FEDERATION INTERNATIONALE DE SKI INTERNATIONAL SKI FEDERATION INTERNATIONALER SKI-VERBAND				

8. Set-Up Diagram Level 1

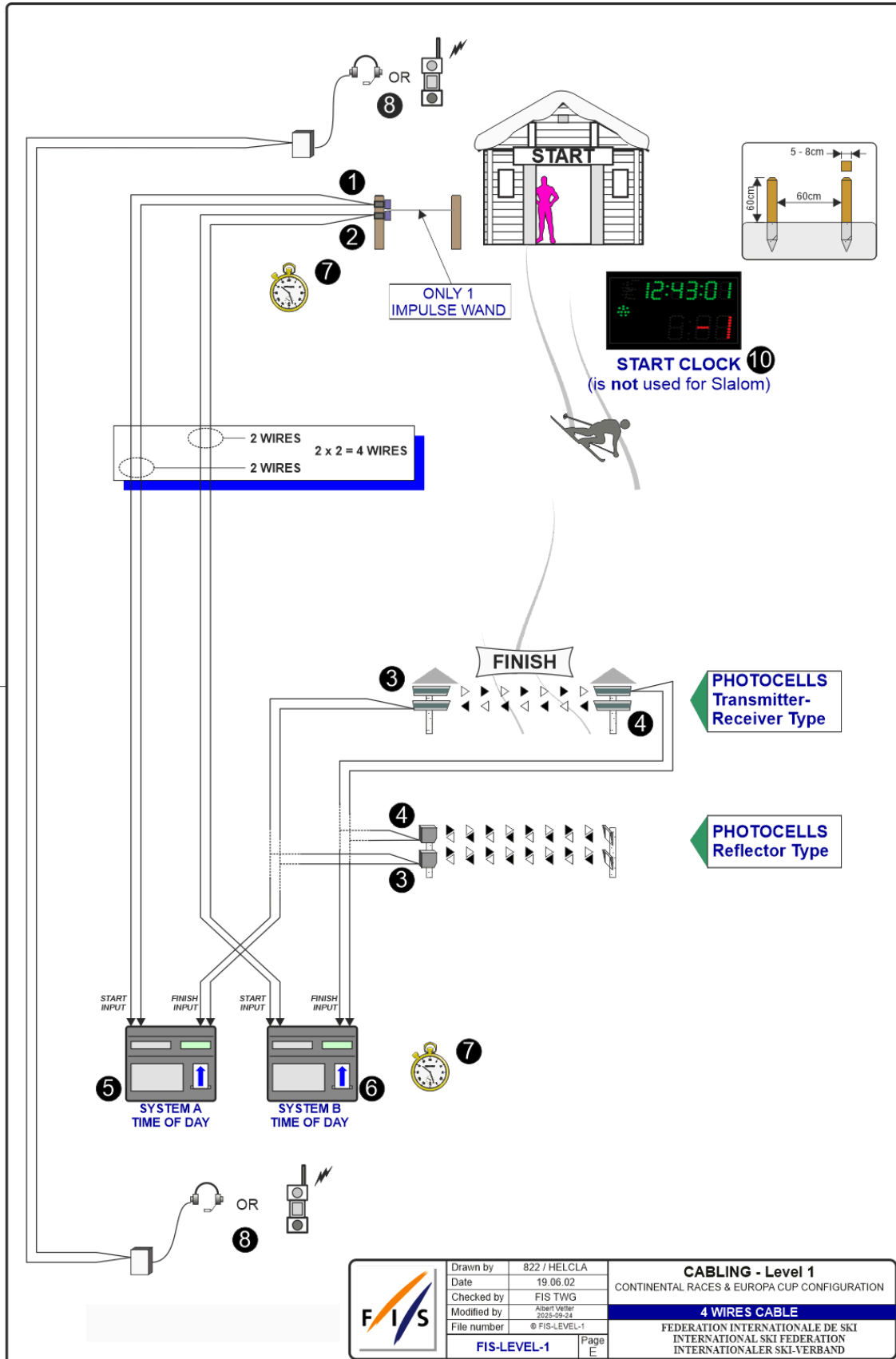

9. Set-Up Diagram Level 2 (Cable)

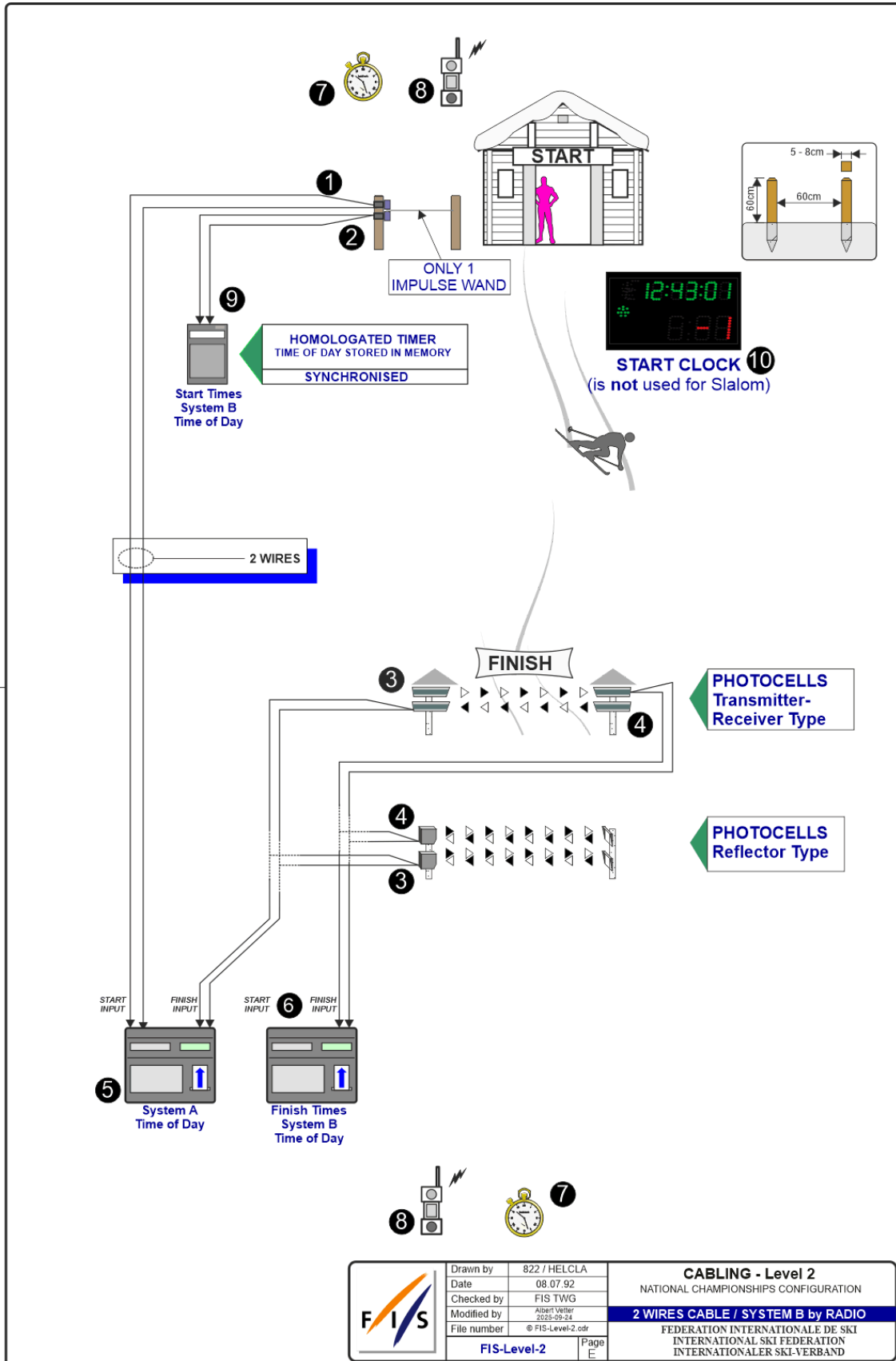

10. Set-Up Diagram Level 3

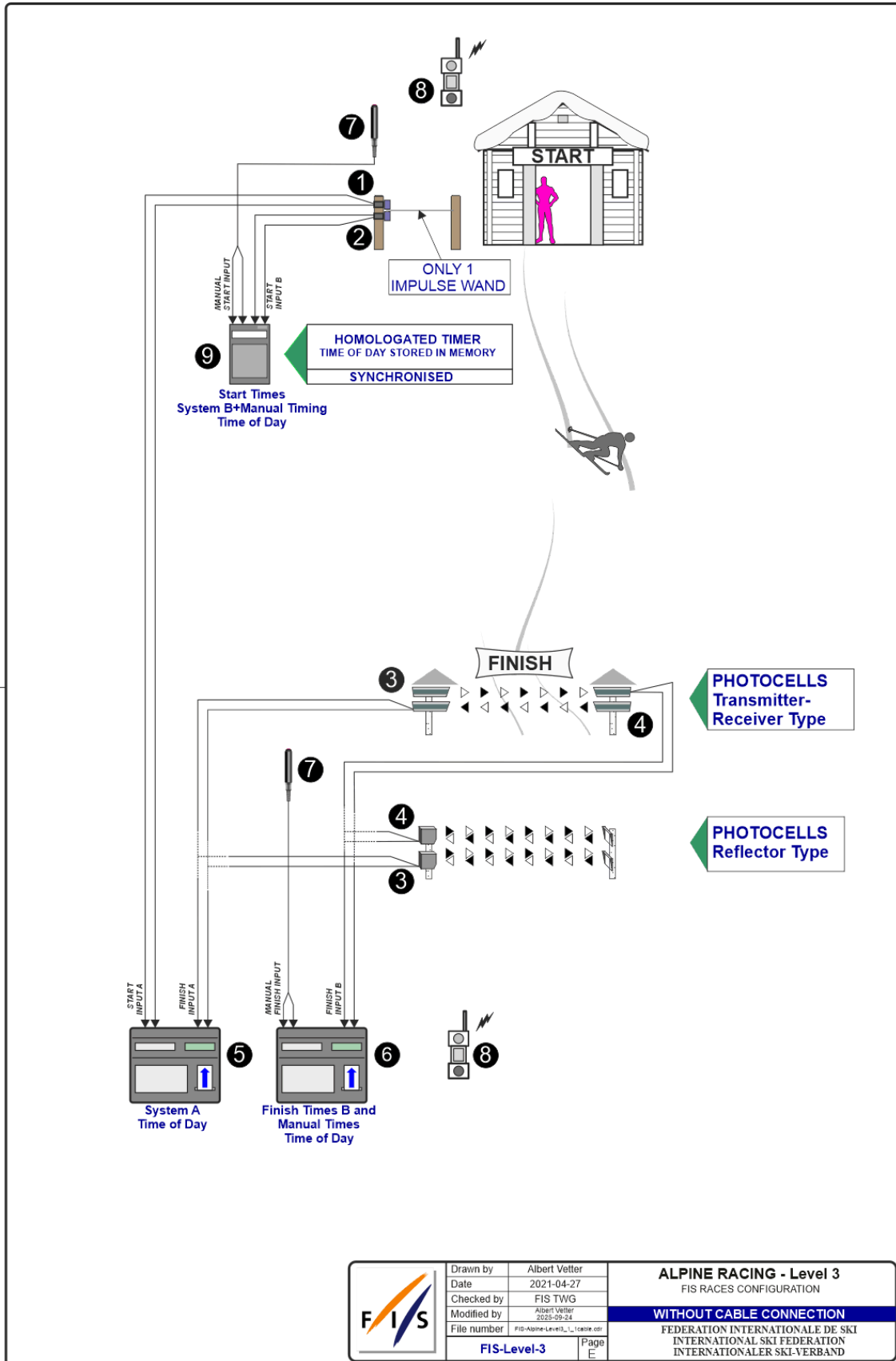

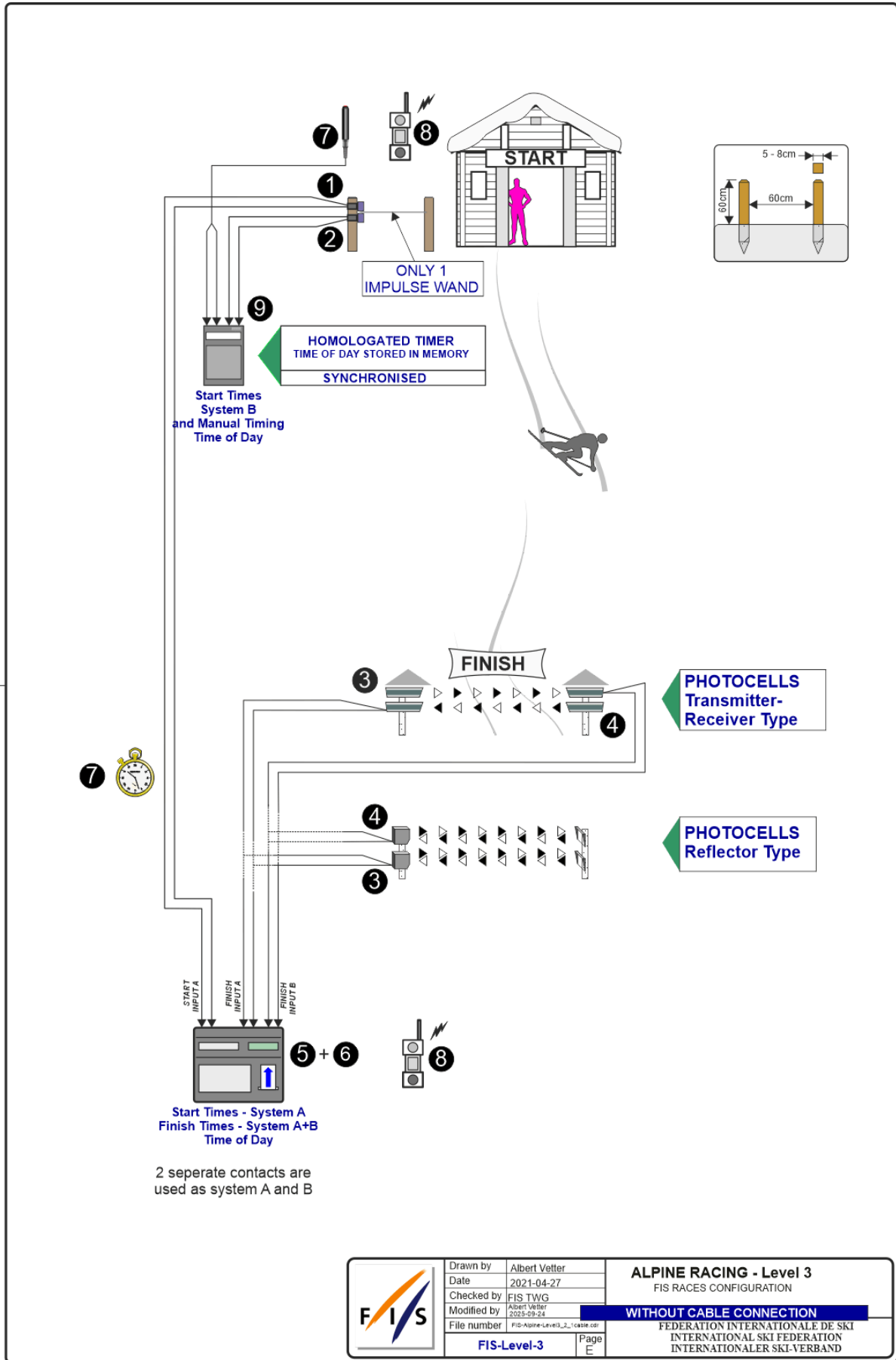

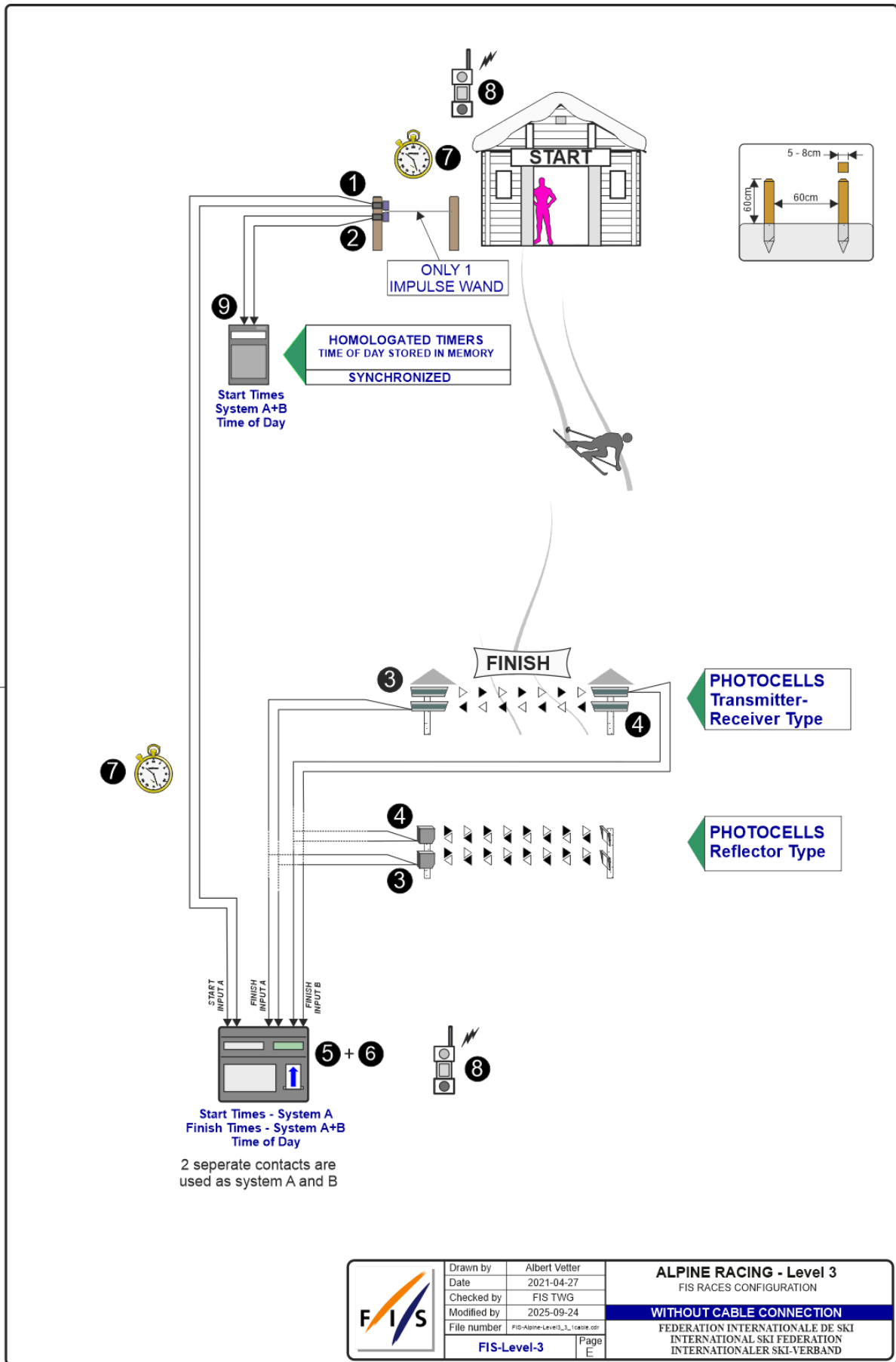

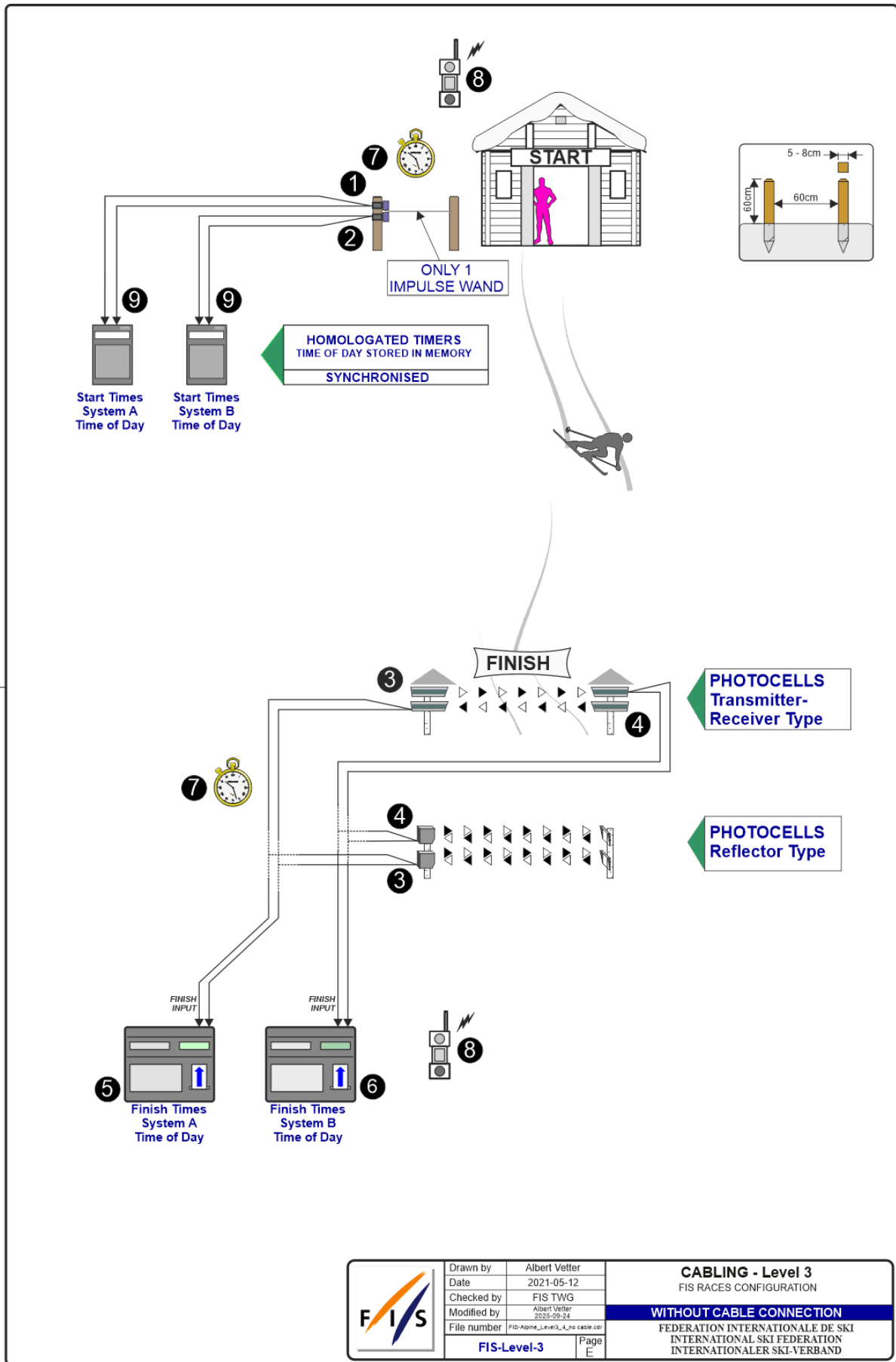

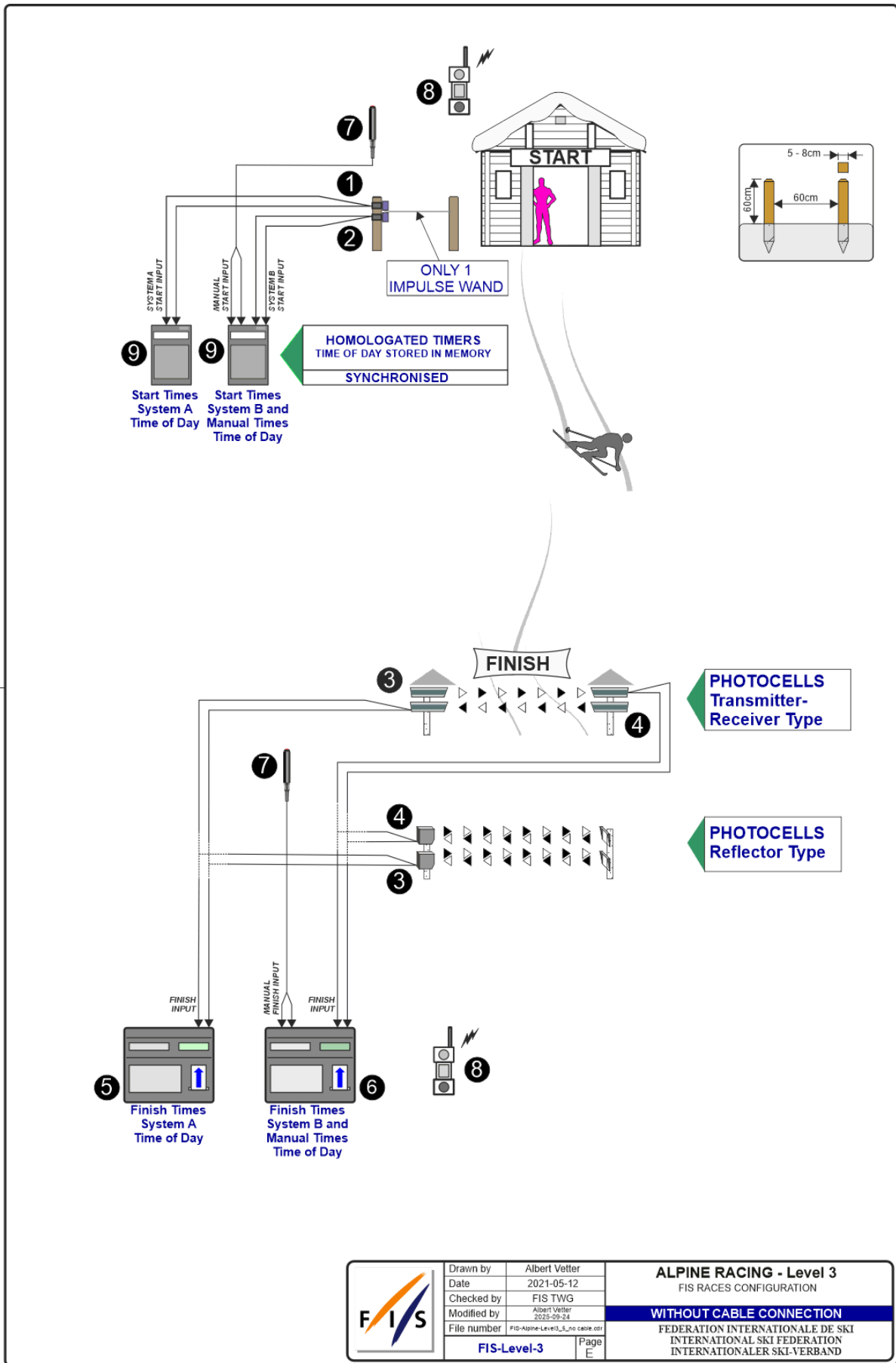

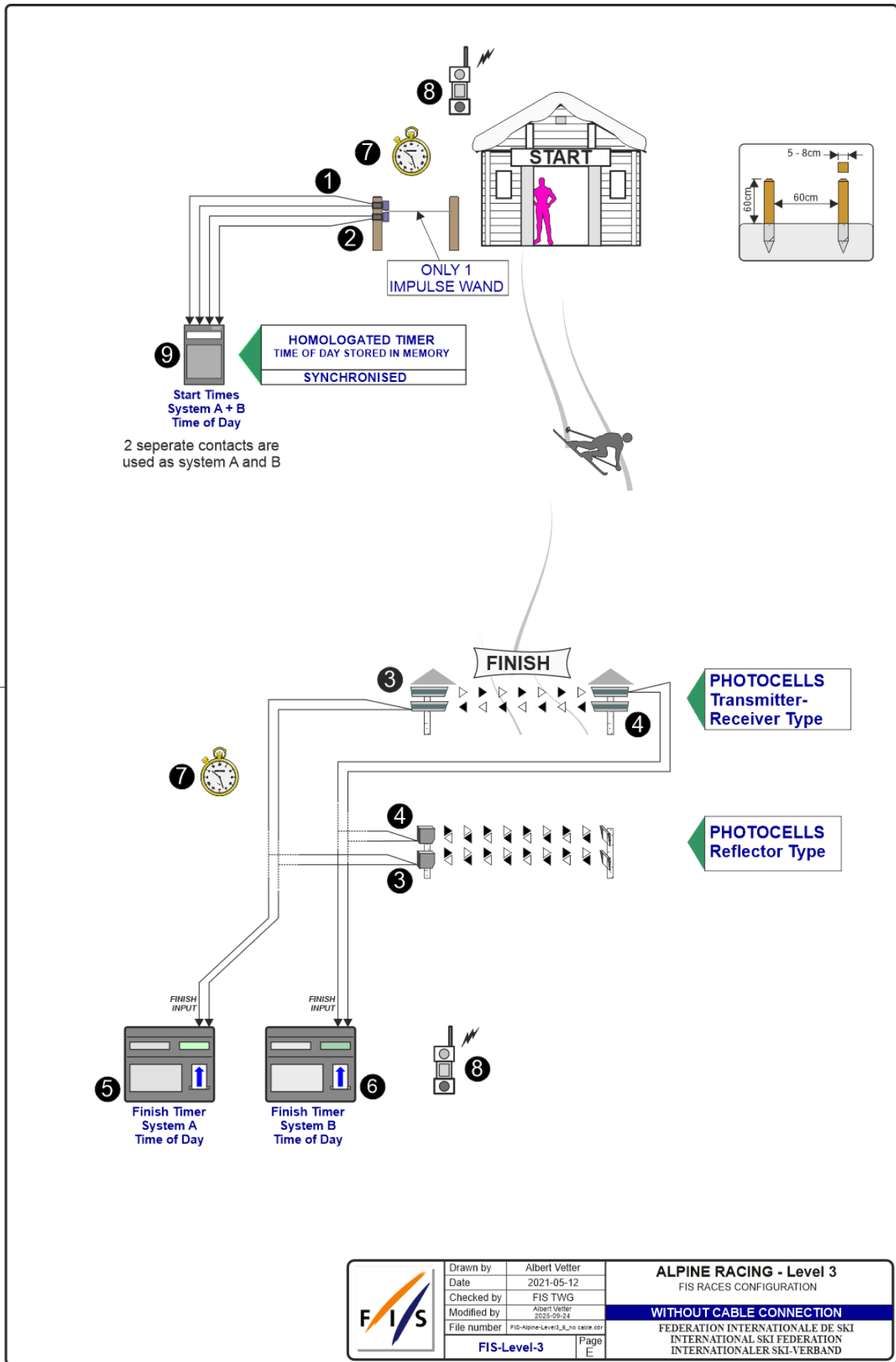

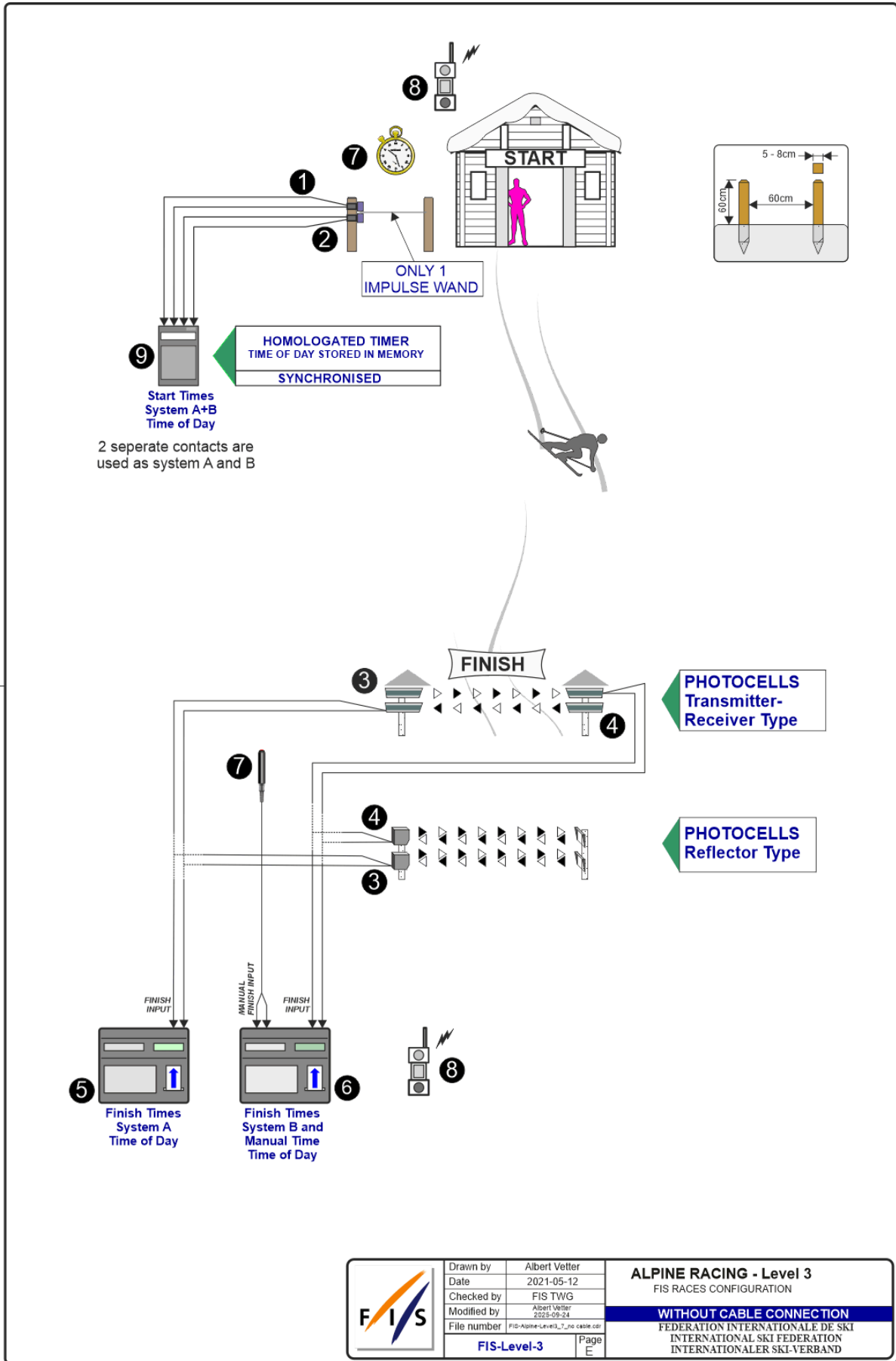

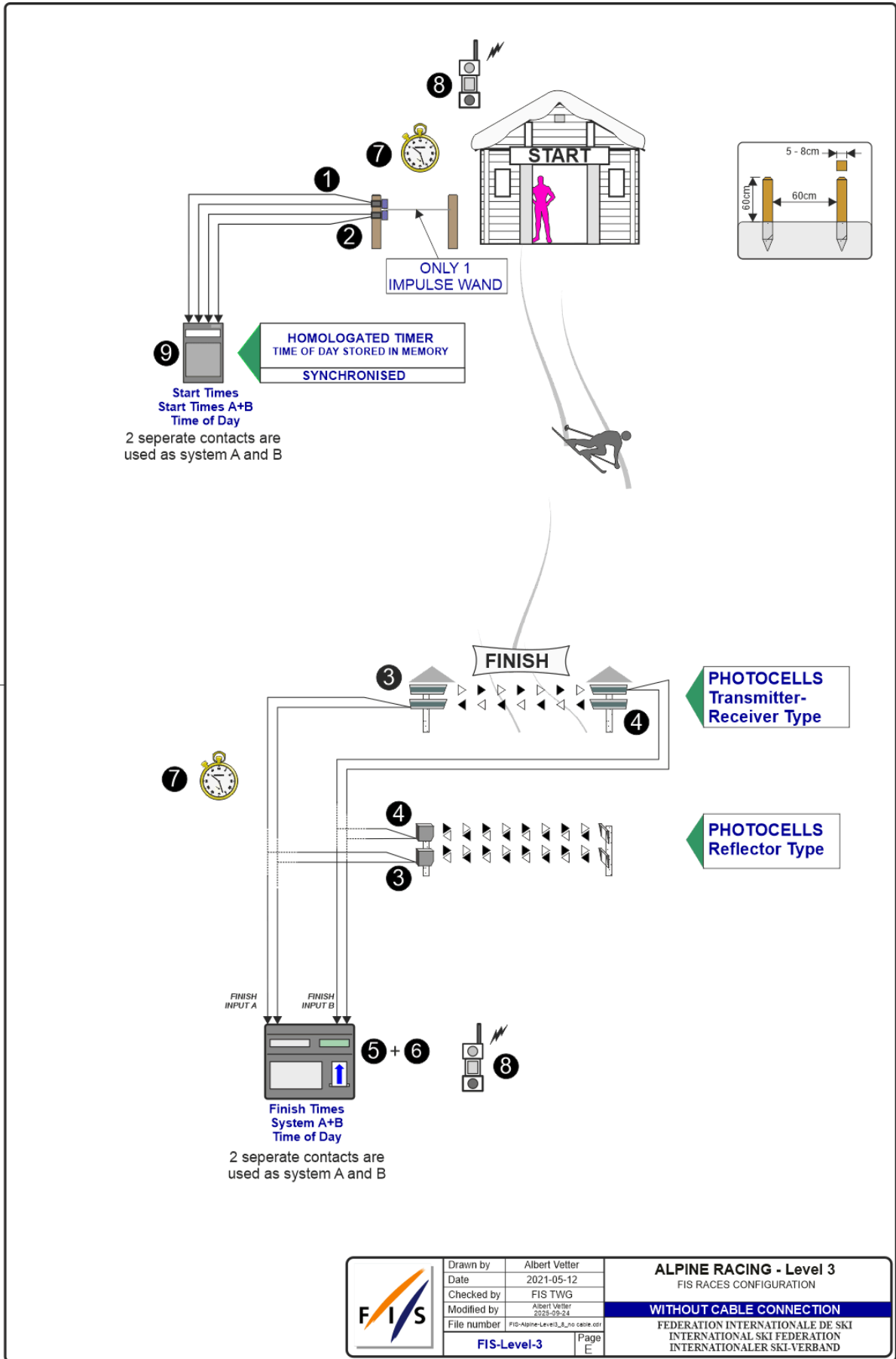

11. Set-Up Diagram for Parallel Competitions Level 0 and 1

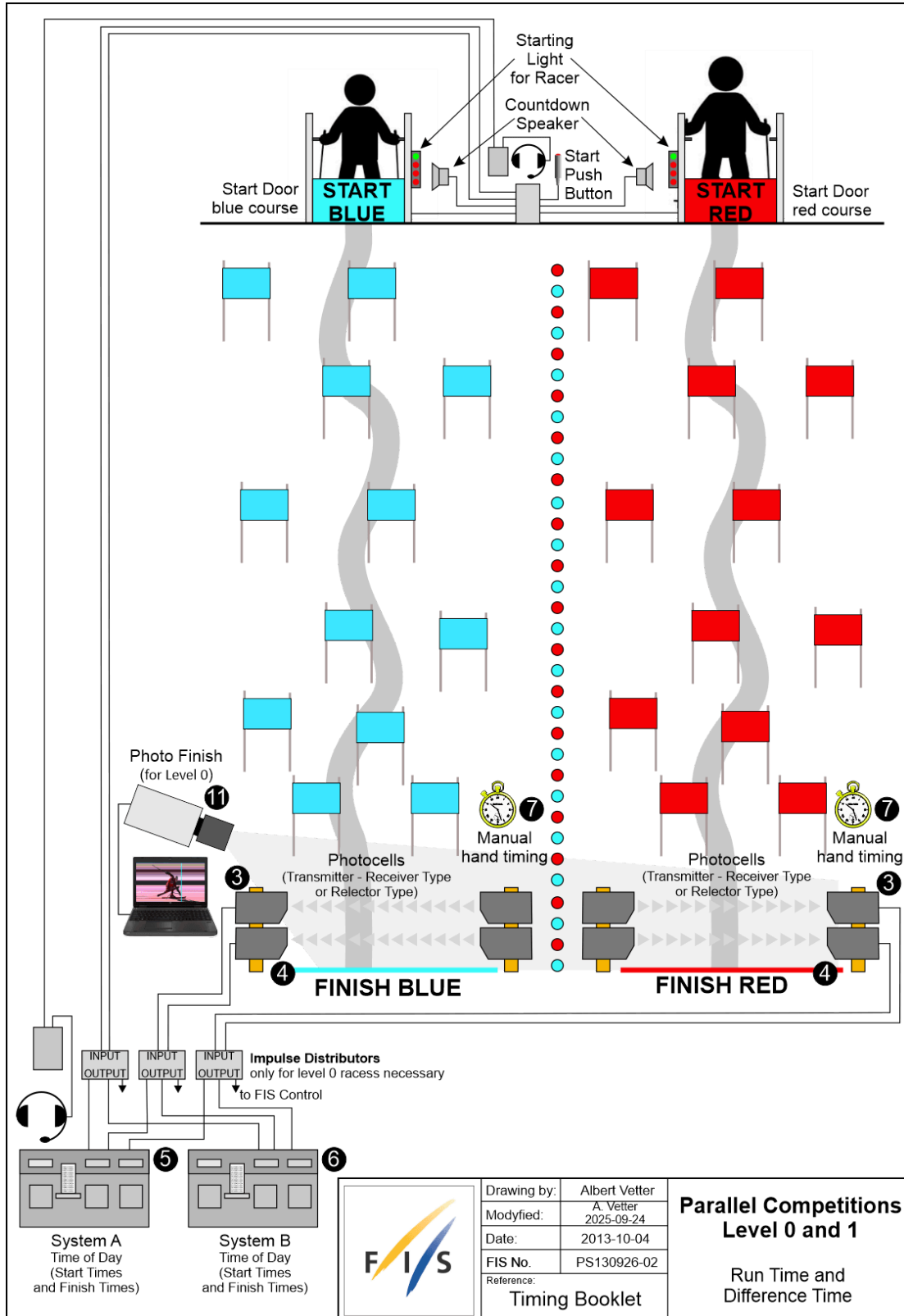

12. Set-Up Diagram for Parallel Competitions Level 2, 3 and 4

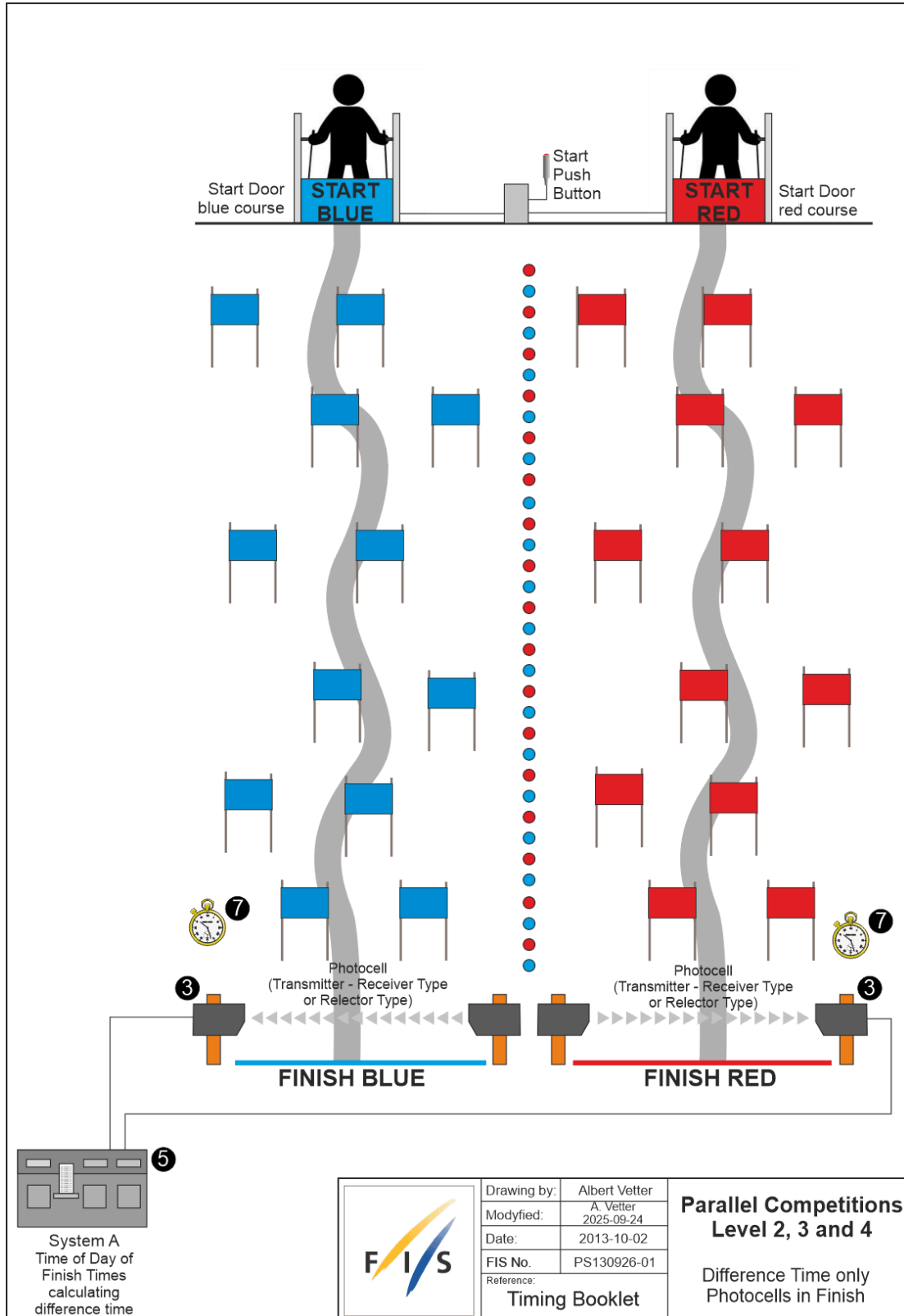

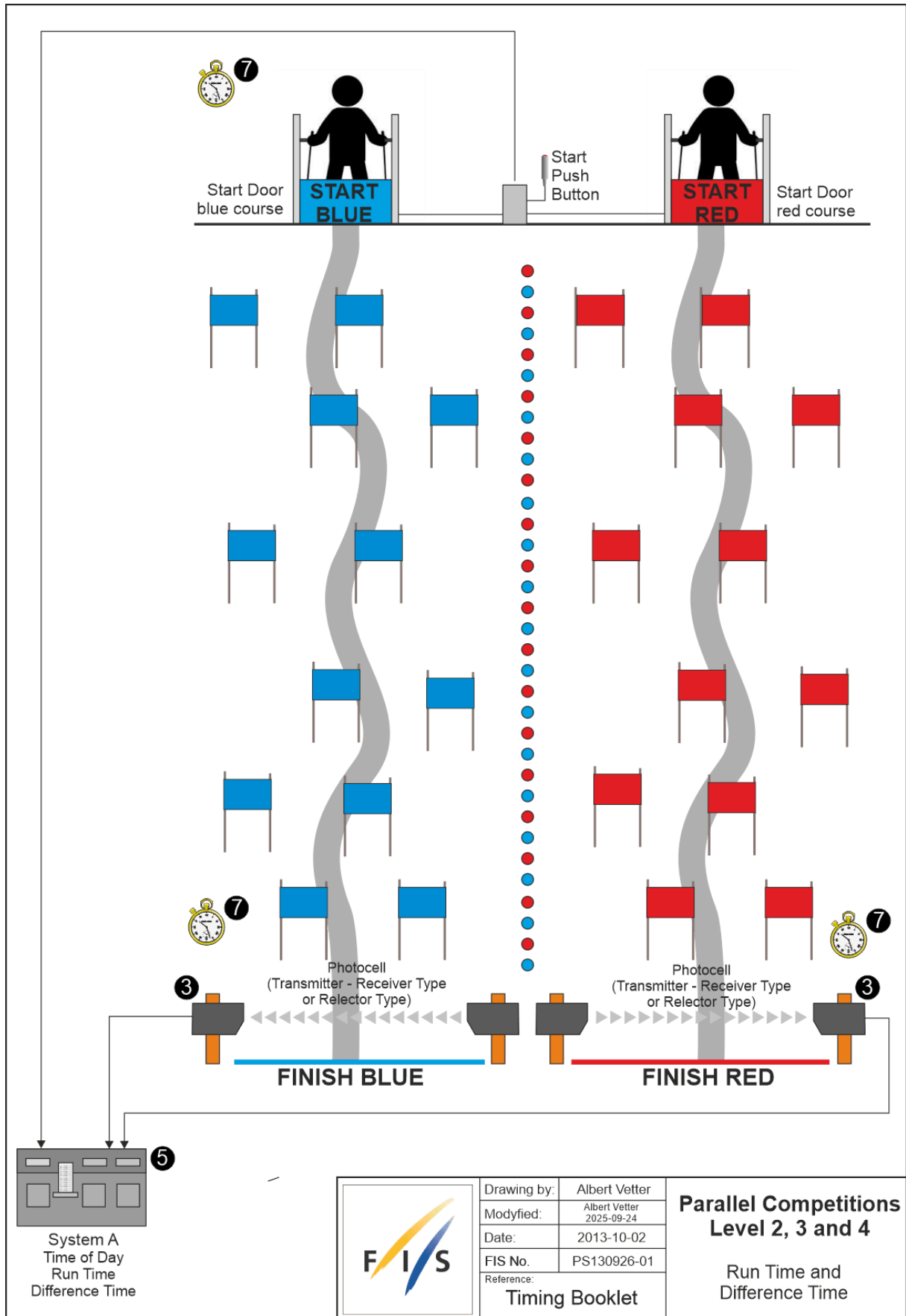

System A
Time of Day
Run Time
Difference Time



Drawing by: Albert Vetter
Modified: Albert Vetter 2025-09-24
Date: 2013-10-02
FIS No. PS130926-01
Reference: Timing Booklet

Parallel Competitions
Level 2, 3 and 4

Run Time and
Difference Time

13. ICR 611 - Technical Installation

611.1 Communications & Cabling

In all international competitions, it is highly recommended that there are multiple communications (telephone or radios, etc.) between the Start and Finish. Voice communication between Start and Finish must be assured by fixed wire connection or radio. In case of radio, this must be on a separate channel from that used by any other function of the OC.

In Olympic Winter Games and FIS World Championships all communications and timing connections between Start and Finish must be assured by fixed wiring.

611.2 Timing Equipment

For all events in the FIS Calendar, electronic timers, start gates and photocells homologated by the FIS must be used. A list of these approved devices will be published. Races using timing equipment other than those on the homologated FIS list will not be considered for FIS points. Specifications and procedures for timing are more fully described in a separate FIS Timing Booklet.

611.2.1 Electric Timing

For all international competitions, FIS World Cup, FIS Continental Cups and FIS competitions, two synchronised electronically isolated timing systems operating in time-of-day must be used. One system will be designated system A (main system), the other system B (back-up system) prior to the beginning of the race. Only exception for Parallel competitions, on Level 2, 3 and 4 where no system B is required.

Time of day times must be immediately and automatically sequentially recorded on printed strips at the maximum precision of the timing device according to the requirements for homologation. The final result is calculated by subtracting the start time from the finish time for each skier's run and is then expressed to 1/100th (0.01) precision by truncating the calculated net time on course.

All times used for the final result must be from system A. If there is a failure of system A, a calculated net time from system B must be used following the same procedure as set out in art. 611.3.2.1. It is not permitted to substitute time-of-day times from system B for use with system A for the purpose of net time calculations.

For all events, system A must be connected to its respective start gate contact. System B must be separately connected to another electronically isolated start gate contact.

Refer to the FIS Timing Booklet for more details regarding cabling and complete wiring descriptions, diagrams and start gate installations.

All timing equipment and technical installation should be set up or protected in such a way that danger to the competitors is avoided where possible.

Synchronisation of the timing systems must occur as close as possible to the scheduled start for the first run of the day. Synchronisation of all systems must be maintained throughout each run. Timers must not be re-synchronised during any run.

611.2.1.1 Start Gate

The start gate must have separate electronically isolated switch contacts for triggering the start inputs of both system A & B.

If a start gate or start wand requires replacement during a run, it must be replaced with identical equipment in the same position

611.2.1.2 Photocells

For all events, there must be two photocell system(s) homologated by the FIS installed at the finish line. One is connected to system A. The other is connected to system B. Procedures and regulations for start gates and photocells are found in the FIS Timing Booklet.

611.2.1.3 Start Clock

For DH, SG and GS, the use of a start clock that provides at least an acoustic countdown signal on the fixed start interval as prescribed by the Jury should be used as an aid to race management. This is mandatory for all Level 0, 1 and 2 races.

611.2.2 Hand Timing

Manual (hand) timing, completely separate and independent of the electronic timing, must be used for all competitions listed in the FIS Calendar. Stopwatches or hand operated battery powered timers that are installed at both the Start and the Finish and capable of expressing the time of day to at least 1/100th (0.01) precision qualify as proper hand timing devices. They must be synchronised prior to the start of the first run, with the same time-of-day as system A and system B (see art. 611.2.1). Printed records, either automatic or hand-written, of recorded hand times must be immediately available at the start and at the finish.

611.2.3 Presentation of times

Organisers should provide appropriate facilities for continuous presentation of all registered times of all competitors.

611.2.4 Timing without Cable

For FIS Level 3 events only, it is permitted to use homologated timing equipment in such a way that hill cable connection between start and finish is not required. Refer to the FIS Timing Booklet for a detailed discussion of how this is possible.

611.3 Timing

611.3.1

With electronic timing, the time is taken when a competitor crosses the finish line and triggers the beam between the photocells.

In case of a fall at the finish where the competitor does not come to a full stop, the time can be taken without both of the competitor's feet having crossed the finish line.

For the registered time to become valid, the competitor must immediately completely cross the finish line with or without skis. With hand timing the time will be taken when any part of the competitor crosses the finish line. The finish controller determines the correctness of passage across the finish line.

611.3.2

In the case of a failure of the main electronic timing system (system A), the results of the electronic back-up system (system B) will be valid as per art. 611.2.1. For the Olympic Winter Games, FIS World Ski Championships and FIS World Cup, a synchronised electronic timing system with printers, connected to the starting gate and to the photocells at the finish is obligatory.

In case of a failure in the lines of the timing system between start and finish, this back-up system will allow the calculation of the times to 1/100ths of a second.

In the case that time of day from either system A or system B are not available for a competitor, the calculated time of day as per art. 611.3.2.1 will be considered valid.

611.3.2.1 Utilisation of times taken by hand (or system B)

Hand times may be used in the official results after a correction has been calculated.

Calculation of the correction:

Subtract the electronic time of day from the time of day taken by hand for the 10

competitors starting before the missing time. If there are not 10 times before, complete the calculation with the remaining times after the missed time.

The sum of the 10 time of day differences is divided by 10 and rounded up or down (0.044 \rightarrow 0.04, 0.045 \rightarrow 0.05) to give the correction which must be applied to the hand time of the competitor without an electronic time.

611.3.2.2 Photo Finish

A Photo Finish System may be used to determine a competitor's finish time. In case of a failure of system "A" and "B", and where the competition has been recorded by the Photo Finish System, this time must be used in place of hand-timing without any correction. The photo finish time is taken when any part of the competitor's body first crosses the Finish line. The photo finish result is to be provided to the Jury only. Photo finish at finish is mandatory for level 0 races.

611.3.3 The official timing strips from the printer will be given to the Technical Delegate for review. They will be kept by the OC until the official approval of the race or after any appeal dealing with timing or race results.

A technical timing report form as prescribed by the FIS must accompany the race results and must be reviewed and sent by the chief of timing and reviewed and confirmed by the TD as his approval of the race.

All printed records from system A, system B and hand timing must be retained by the OC for a period of three (3) months after the competition or after any appeal dealing with timing or race results.

611.3.4 When the official printing timer allows manual input or correction of a time, some type of indication (star, asterisk or other) concerning any effected change must be printed on all timing documentation.

611.3.5 Computer software calculating net times must use the precision of the time of the day as used in the timing device.

611.5 Private timing and speed measurement equipment of the Teams

Any request to install such equipment has to be made to the Jury by the team captain concerned, and the Jury decides concerning approval of the installation. At Olympic Winter Games, FIS World Ski Championships and FIS World Cup only the organisers' timing equipment is permitted.

14. EET Calculation

The EET (Equivalent Electronic Time) you need in case a time from system A is missing. All times used for the final result must be from system A. If there is a failure of system A, a calculated net time (EET) from system B must be used following the same procedure as shown below. It is not permitted to substitute time-of-day times from system B for use with system A for the purpose of net time calculations. If the time is not available from system B use the photo finish time (if available), otherwise hand time.

Calculation of the correction:

To calculate the correction time, use the 10 times of day of the competitors started before the one with the missing time. If there are not 10 times before, complete the calculation with the remaining times after the missed time.

Subtract the A system times from the back-up times for these 10 competitors. In case of parallel events, this can be less than 10 times and the qualification and the finals times must be not used together.

The sum of the 10 calculated time differences (in case of parallel events, the times per course should be considered) is divided by 10 and rounded up or down (0.0444 = 0.044, 0.0455 = 0.046). This correction time must be added or subtracted to the replacement time of the competitor without a system A time.

The EET calculation must only use time of day precision to a minimum 1/1000th for the correction value of the time of day. If Hand timing is only available to precision of 1/100th, the full precision of 1/1000th or better must be used for the system A times.

Electronic A Finish Time in TOD: 10:48:31.9781

Hand Timing: 10:48:31.86(00)

Rounding for EET-Time Calculation (*):

$1.1575 / 10 = 0.11575 \Rightarrow 0.1158$ (rounding up for 5 or higher)

$1.1574 / 10 = 0.11574 \Rightarrow 0.1157$ (cutting below 5)

14.1. EET Calculation - Example if System A and Backup Time has the Precision of 1/1000th

BIB	Time of Day System B or Manual Time	Time of Day System A	Time Difference	Explanation
11	13:00:00.483	13:00:00.263	0.220	time difference of BIB 11
12	13:00:26.521	13:00:26.880	-0.359	time difference of BIB 12
13	13:00:47.410	13:00:47.368	0.042	time difference of BIB 13
14	13:01:04.232	13:01:04.368	-0.136	time difference of BIB 14
15	13:01:27.544	13:01:27.775	-0.231	time difference of BIB 15
16	DNF	DNF	0.000	Racer did not finish
17	13:02:12.993	13:02:12.912	0.081	time difference of BIB 17
18	13:02:42.501	13:02:42.616	-0.115	time difference of BIB 18
19	13:03:00.211	13:03:00.944	-0.733	time difference of BIB 19
20	13:03:20.694	13:03:20.280	0.414	time difference of BIB 20
21	13:03:48.560	13:03:48.559	0.001	time difference of BIB 21
22	13:04:12.158	missed time	-0.816	sum of above time differences
Calculate Correction Time			-0.0816	0.0816 = 0.816 / 10
Correction Time after Rounding*			-0.082	
Calculate EET Time: Source Time - Correction Time				
22	13:04:12.158 - (-0.082) = 13:04:12.240			
EET for Bib 22	13:04:12.240			

14.2. EET Calculation - Example if System A and Backup Time has the Precision of 1/10000th

BIB	Time of Day System B or Manual Time	Time of Day System A	Time Difference	Explanation
1	10:00:50.3548	10:00:50.1292	0.2256	time difference of BIB 1
2	10:01:52.0189	10:01:52.1921	-0.1732	time difference of BIB 2
3	10:02:49.4978	10:02:49.4920	0.0058	time difference of BIB 3
4	10:03:50.6148	10:03:50.9812	-0.3664	time difference of BIB 4
5	10:04:49.2741	10:04:49.8729	-0.5988	time difference of BIB 5
6	10:05:50.4702	10:05:50.5129	-0.0427	time difference of BIB 6
7	10:06:48.9125	10:06:48.8615	0.0510	time difference of BIB 7
8	10:07:51.5814	missing time	0.0000	missing time
9	10:08:49.8751	10:08:50.0002	-0.1251	time difference of BIB 9
10	10:09:49.2459	10:09:49.4278	-0.1819	time difference of BIB 10
11	10:10:50.3954	10:10:50.3473	0.0481	time difference of BIB 11
8	10:07:51.5814	missing time	-1.1576	sum of above time differences
Calculate Correction Time			-0.11576	-0.11576 = 1.1576 / 10
Correction Time after Rounding*			-0.1158	
Calculate EET Time: Source Time - Correction Time				
8	$10:07:51.5814 - (-0.1158) = \mathbf{10:07:51.6972}$			
EET for Bib 8		10:07:51.6972		

14.3. EET Calculation - Example if Using a Hand Time with 1/100th

BIB	Time of Day System B or Manual Time	Time of Day System A	Time Difference	Explanation
1	10:00:50.35(00)	10:00:50.1292	0.2208	time difference of BIB 1
2	10:01:52.01(00)	10:01:52.1921	-0.1821	time difference of BIB 2
3	10:02:49.49(00)	10:02:49.4920	-0.0020	time difference of BIB 3
4	10:03:50.61(00)	10:03:50.9812	-0.3712	time difference of BIB 4
5	10:04:49.27(00)	10:04:49.8729	-0.6029	time difference of BIB 5
6	10:05:50.47(00)	10:05:50.5129	-0.0429	time difference of BIB 6
7	10:06:48.91(00)	10:06:48.8615	0.0485	time difference of BIB 7
8	10:07:51.58(00)	missing time	0.0000	missing time
9	10:08:49.87(00)	10:08:50.0002	-0.1302	time difference of BIB 9
10	10:09:49.24(00)	10:09:49.4278	-0.1878	time difference of BIB 10
11	10:10:50.39(00)	10:10:50.3473	0.0427	time difference of BIB 11
8	10:07:51.58(00)	missing time	-1.2071	sum of above time differences
Calculate Correction Time			-0.12071	-0.12071 = 1.2071 / 10
Correction Time after Rounding*			-0.1207	
Calculate EET Time: Source Time - Correction Time				
8	10:07:51.58(00) - (-0.1207) = 10:07:51.7007			
EET for Bib 8	10:07:51.7007			

15. Timing & Data Technical Report Form

The FIS provides free of charge a software program to fill out the "Timing & Data Technical Report". You can download it from the FIS-website under „Alpine Skiing“, „More“ and „Timing & Data“:

<https://www.fis-ski.com/inside-fis/general-fis-documents/timing-data#Timing%20Report>

The software download is available for Windows and macOS.

With the electronic report the timekeeper can send the report independently from the TD to the FIS. The timekeeper just goes through the form and fills in all the fields required for each discipline and sends it as XML file. Of course, the timekeeper can still print the timing & data technical report to have a printed document.

The FIS only accepts the Timing & Data Technical Reports that are sent as XML file. Printed reports that are sent by mail, fax or e-mail will not be accepted.

A detailed documentation of the Timing Report software can be found on the FIS website Timing & Data section:

<https://www.fis-ski.com/en/inside-fis/document-library/timing-data>

or within the Timing Report software.

16. Criteria for FIS Approved Timing Devices for Alpine Ski Races

All timing devices must be homologated by FIS and used respecting FIS rules.

16.1. Timers

Timer	<p>The timing device must have an internal printer or external printer (e.g. RS232, RS422, USB, Ethernet, WLAN, Bluetooth).</p> <p>Printing through a computer is not allowed.</p> <p>The timer must be able to operate in Time-of-Day. The output of the time must always have the same precision (e.g. printer, display and interface).</p>
Printer	<p>This printer must print at least in a chronological order the time of day. For each printed time of day there must be an indication of the timing channel.</p> <p>If it is possible to do manipulation or correction of times in the timer the printer must mark such a corrected time.</p>
Interface	<p>The timing device needs an interface (e.g. RS232, RS422, USB, Ethernet, WLAN, Bluetooth) to connect a PC and transfer the data for data processing (result service) online. The communication protocol must be forwarded to the FIS for the homologation test.</p>
Power Supply	<p>The timing system must work with both, internal batteries, and external power.</p> <p>The timing system must work without power supply from the mains for one (1) hour at 23°C with one printout per minute, two (2) hours at – 10°C with one printout per minute and 30 minutes of warmup to 60°C with one printout per minute.</p>
Operation Temperature	<p>The timing device and printer must work at ambient temperatures from –10° to +60°C</p>
Measuring Range	<p>Time of day mode must be possible in hours, minutes, seconds and 1/10000, or better.</p>
Timer Precision	<p>Must measure 1/10000 second or better in time of day mode.</p> <p>Timer accuracy must be below +/- 10 PPM at a device temperature from –10° to +60°C.</p>
Quartz	<p>Ageing of the quartz must be below +/- 3 PPM per year.</p> <p>The time drift must be below +/-0.5 PPM at a constant temperature of 23°C.</p>

Impulse Triggering	<p>The delay of impulses is not allowed to be higher than 1/1000 sec. for the same channel (the channel is triggered from a reference impulse device in minute intervals). If two channels are triggered at the same time the times must be within 1/1000 second.</p> <p>The delay of impulses must be constant; the gap between both channels must be max. 1/10000 sec.</p>
Timing Channels	<p>The timing device needs a minimum of two independent channels, one for start and one for finish.</p>
Synchronisation	<p>Synchronisation between main- (System A) and backup timer (System B) must be possible.</p>
Memory	<p>The timing device needs an internal static memory that stores the time of day with the timing channel and manipulations. It must be possible to send the data of the memory in chronological order through an interface to another device (e.g. PC).</p>
Electromagnetic	<p>The timing device must meet the standards of IEC (International Electronic Commission). This means the timing device must function satisfactorily in its electromagnetic environment without introducing intolerable electromagnetic disturbances to anything in that environment.</p>
Truncation	<p>The truncation to 1/100 of seconds must be made after the calculation of the run time. The digits of the run time after the 1/100 are thrown away.</p>

Example:

Start Time:	10:00:00.1327
Finish Time:	10:01:30.2599
Calculated Run Time:	00:01:30.1272
Run Time after truncation:	00:01:30.12

16.1.1. Timers with Permanent External Synchronisation

For timing devices with permanent external synchronisation (e.g. GPS-Synchronisation) all specifications of “Timers” (see previous page) are valid. Additionally, it must fulfil the following features:

- The permanent external synchronisation solution must have a constant accuracy from 0.0001 s or better.
- The timing device must run independent with the internal quartz.
- The time synchronisation of the external device can be in periodic intervals or permanent.
- If the difference between the internal timing (quartz) and the external synchronisation is within an accuracy of ± 0.0003 seconds it is allowed to resync the timing device with the external time.
- If the difference between the internal time (quartz) and the external time is higher than ± 0.0003 seconds it is not allowed to resync the timer with the external time. From now on the timing device must run with the internal quartz only (no further resynchronisations are allowed).
- The printer of the timer must print a message when the permanent external synchronisation is switched off. The message must inform about the reason for switching the permanent external synchronisation off and the time when this happens.
- In case the permanent external synchronisation signal is lost the timer has to print it a message. If the timer gets the synchronisation signal again further synchronisation is allowed, if the time difference is within the allowed ± 0.0003 seconds.

16.2. Start Gate

Install the Start Gate in close co-ordination with the Technical Delegate and/or the Race Jury. Only Start Gates homologated by FIS are allowed (see section of [homologated timing equipment](#) in this booklet and on FIS website).

The following elementary rules should be considered:

- Start Gate mounting post must be put into the ground or snow or firmly connected to a fixed structure under the snow. It is essential that the support post be solidly fixed and not permitted to move in any way.
- The Start Gate must likewise be attached to the mounting post without the possibility of rotation or movement of any kind.
- The height above the ground of the Start Gate must permit the athletes to hit the bar below the knee not too close to the boot top. In all cases the range shall not be less than 35cm nor more than 50 cm above the snow surface at the start.
- The start gate may be placed either to the left or the right of the starting competitor, in all cases making sure that the angle of departure to the first gate ensures that the start gate must open.

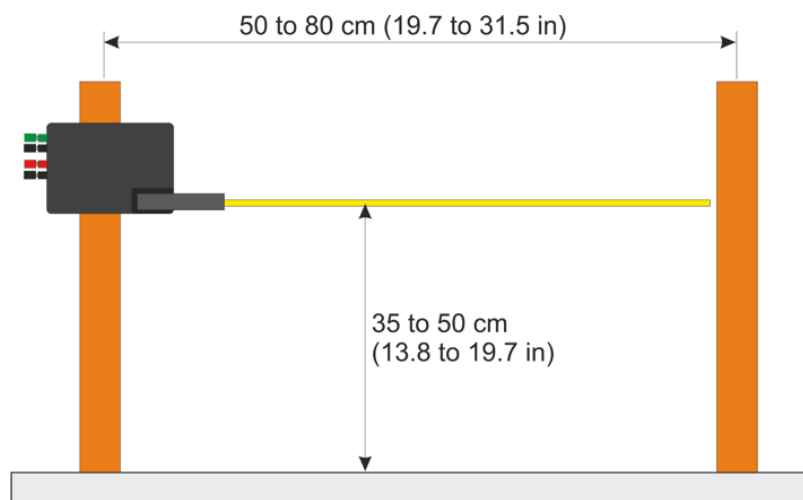

- The length of the wand (bar) must be within 50 cm (20 in) and 80 cm (31.5 in)
- The Start Gate must have two different and completely isolated lines, two separate connectors, one for timing system A and one for timing system B

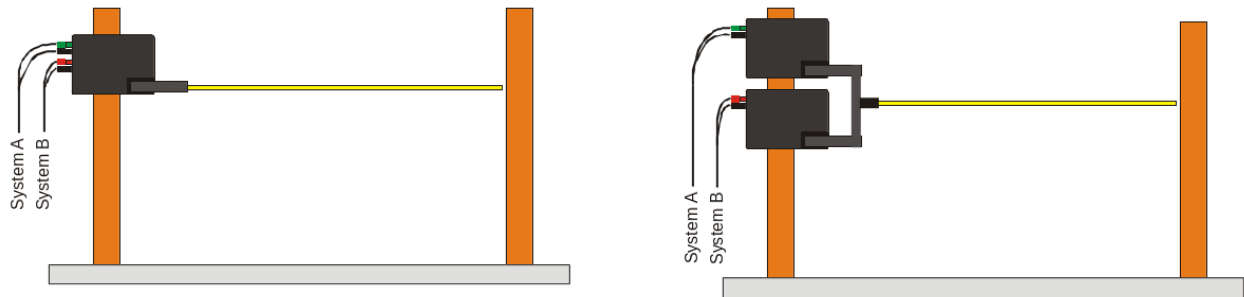

- If two Start Gates are used in parallel, they must be solidly mounted on the same physical bracket and each arm must be stiffly connected together (both mechanism and box)
- Only the use of one wand (bar) is permitted for able body
- If the Start Gate has to be replaced during the competition, it must be a Start Gate of the same type and manufacturer
- The position of the Start Gate (both height and rotation) must be marked before the beginning of the competition in order to make sure that a replacement can be installed in the same position if necessary

16.2.1. Para competitions

Para athletes have varying impairments, which require a tailored setup to the start gate and start area.

- Two wands (bars) are required for para. One at the able body position (35 to 50cm) and another for sit ski athletes which should be placed at 80cm.
- Adequate space for the guide should be considered at the start. It is recommended to have a minimum of one (1) meter on the side of the post that is in relation to the first gate of the course. The space should be at the same level as the competitor. All cabling should be laid on the opposite post to avoid disruption from the guide.
- For VI and Standing categories, the lower wand should be used, for Sitting, the upper wand. The non active wand should be disabled while not in use.

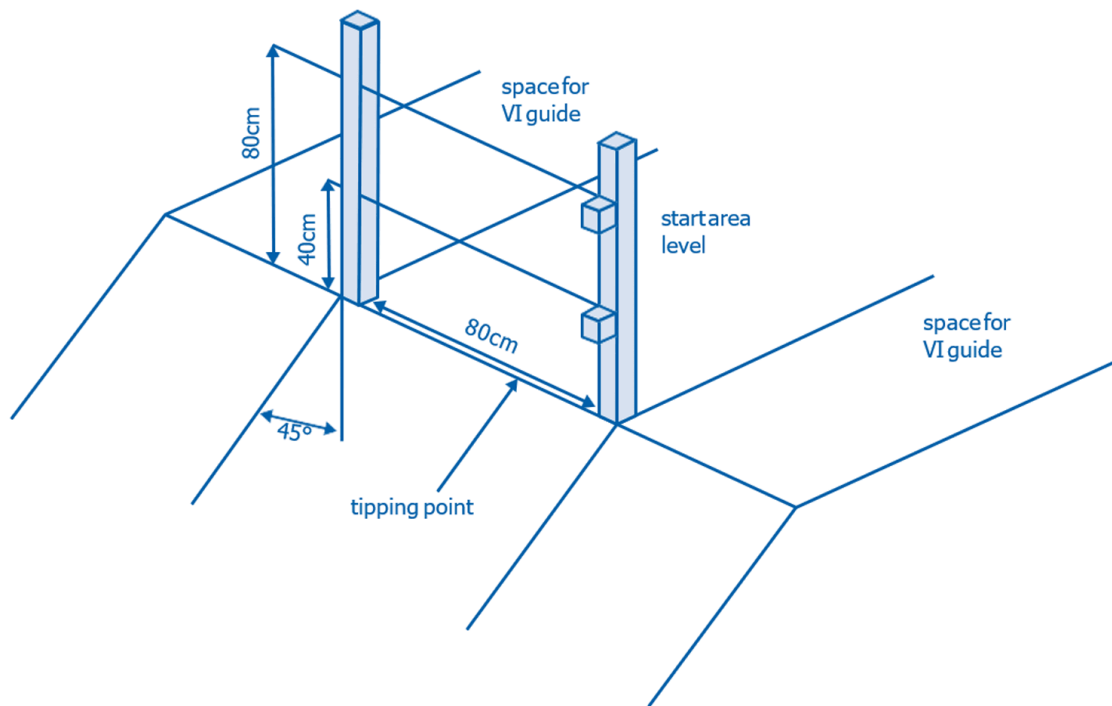

16.2.2. Technical Specifications for Start Gates:

Only Start Gates that meet the following technical specifications will be homologated by FIS:

Contacts

The Start Gate shall provide a separate contact for system A and B. Each contact needs a separate, but identical switch. Both contacts must be completely electrically separated.

Angular Range

Both impulses must be given at an angular range of the start wand between 10° and 30°, calculated from the closed position (when the wand is stiff). Starting gates that do not meet this trigger angle are not admitted.

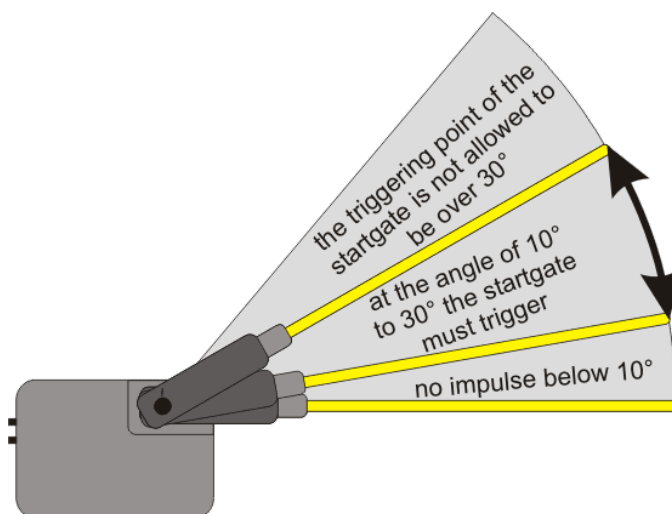

Angular Accuracy

Both impulses shall be given by starting gate switches of the same type with an angular accuracy of +/- 5° respect to the indicated rotation of the start wand.

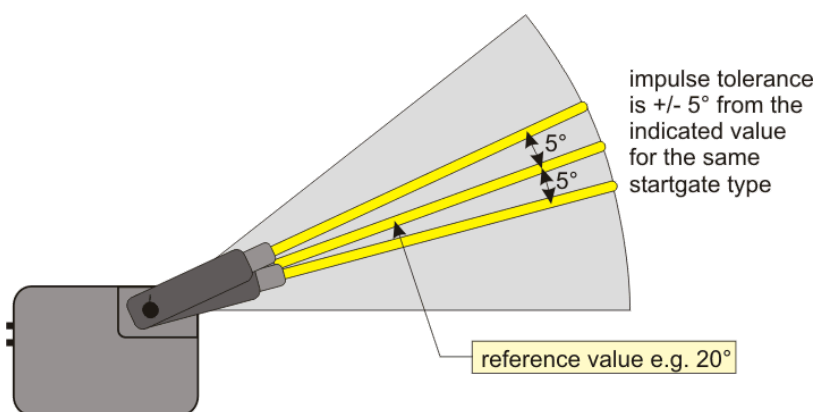

Start Wand

The start wand cannot be so stiff that it could cause injury and that it will not break. On the other hand, it must be as stiff as possible to avoid unfair starts. If you rotate the start wand at the far end, it is not allowed to bend more than 15° without causing the triggering mechanism to actuate.

The wand must stay open once it is activated. Spring return "Self-Returning" mechanisms are not permitted. For Cross-Country an automatic rewinding start gate is allowed.



Start Gate Impulses

Two different possibilities are accepted:

- 1) Single Shot:** the line is activated for predetermined time even if the wand remains open
- 2) Continuous:** the line remains activated as long as the wand remains open.

16.3. Start Clock

Display	<p>The start clock has a visible start display to the athletes. The display can be analogue or digital.</p> <p>Analogue Clock: The clock must be visible over a distance of at least 10 m</p> <p>Digital Clock: The figures must be visible over a distance of at least 10 m</p> <p>Time of day: hours, minutes and seconds (min. 6 digit)</p> <p>Countdown: minutes and seconds (min. 3 digit)</p> <p>Bib: to show the bib is not mandatory, but can be an option</p>
Start Indicator light	The start clock must show if the start is free (green indicator) or not allowed (red indicator).
Acoustic Countdown	<p>The start clock needs an acoustic countdown. The acoustic countdown has at least one beep at each second during the last five seconds (low tone from five seconds to 1 second and high tone at zero).</p> <p>The acoustic signal emitted by the device must be capable of producing a sound level of at least 100 dB when measured at a distance of 1 meter from the device, 1 meter above ground.</p>
Countdown	The start clock needs at least three start interval countdown times. During the race it must be possible to change from one start interval to another. The duration of each start interval must be adjustable at any time (before the race or during the race).
Power Supply	<p>The start clock must work without power supply from the mains for eight (8) hours at 23°C and an interval of 1 min.</p> <p>The start clock must work without external power supply on internal batteries for 6 (six) hours at -20° C.</p>
Operation Temperature	The start clock must work at ambient temperatures from -20° to +60°C.
Measuring Range	Time of day mode must be possible.
Timer Precision	Timer accuracy must be below +/- 10 PPM at a device temperature from -10° to +60°C.
Quartz	<p>Ageing of the quartz must be below +/- 3 PPM per year.</p> <p>With an adjusted quartz frequency, the time drift must be below +/-0.5 PPM at 23°C.</p>
Impulse Triggering	<p>The delay of impulses is not allowed to be higher than 1/1000 sec. for the same channel (the channel is triggered from a reference impulse device in minute intervals).</p> <p>The delay of impulses must be constant; the range must be less than 1/1000 sec.</p>
Timing Channels	The timing device needs timing channels that allows the synchronisation of the device and output of the start impulse (zero tone, e.g. start impulse for timing device).
Synchronisation	Synchronisation with other timing devices must be possible.

Electromagnetic

The timing device must meet the standards of IEC (International Electronic Commission). This means the timing device must function satisfactorily in its electromagnetic environment without introducing intolerable electromagnetic disturbances to anything in that environment.

16.4. Start Door

A start door homologated by the FIS is needed for the following events: parallel events, team events, Boarder Cross, Ski Cross.



- Dimension of the hinged flap panel, outside the snow must be more than 95 cm wide, 25 to 40 cm height
- The side that has contact with the skis must be protected using material that protects the skis.
- Competitors must not be able to push the gates open. A force applied at any position on the hinged flap panel at 25 cm above the snow with 150 N is not allowed to open or block the start door.
- A handle is on each side of the start door. It is used for the competitors to start. The handle is mounted on the inside. The handle must be adjustable in the height between 60 and 100 cm (measured from the snow level).
- One push button must start the automatic start sequence for all involved start doors.
- The start door or start-electronic must provide an output channel to start the timing.
- The start door must be able to be opened with a delay (e.g. for one racer at the second run at parallel races). For level 0 events it is mandatory.
- The start door must have a potential free impulse output to connect a timing device (one output contact for each start door).
- Starting lights visible for the athletes may be available for parallel competitions and team events. Red light(s) shows the countdown and a green light the start (door opens). The lights show the countdown from 3 seconds to zero. For level 0 it is mandatory. For cross events the starting lights must be able to be switched off.

- Starting sound for the athletes may be available for parallel competition and team event. It is counting down synchronic with the light from 3 seconds to zero. The sound and light must start exact with the full second. For level 0, 1 and 2 it is mandatory. For cross events the starting sound must be able to be switched off or changed to one start tone.
- Sound and light must be synchronized. Same sound for the red lights and different sound for green light.
- For Cross-Events the hinged start panels must be connected for all gates by one bar. This means all gates must open at the same time.
- The manufacturer of the start door must provide a checklist to maintain the start door. Before each FIS race that uses the start door the start door has to be checked by the checklist and a copy of the checklist has to be provided to the TD at least 2 weeks before the race.
- Validity of the homologation is 10 years, it can be homologated for parallel, cross or both.

16.4.1. Startdoor Measurements

Description	Specifications
Distance between handles [A]	80 - 90 cm
Handle height over snow [B]	adjustable, 60 - 100 cm
Vertical handle movement [C]	max. 10 cm step
Handle diameter [D]	3 - 5 cm
Width of hinged flap panel [F]	min. 95 cm
Height of hinged flap panel over the snow [G]	25 - 40 cm
Distance between start doors for cross events [H]	60 - 70 cm
Closing angle of hinged flap panel	0 - 15°
Opening angle of hinged flap panel	min. 140°
Time to open hinged flap panel to 90°	max. 0.3 s
Variation of opening duration of hinged flap panel	max. 0.1 s
Time to open hinged flap panel from start impulse to 90°	max. 0.4 s
Force applied on hinged flap panel to 25 cm over snow level without opening	min. 15 kg
Operating temperature	-30°C to +60°C
Surface of hinged start panel (side that skier moves over)	protection for skis

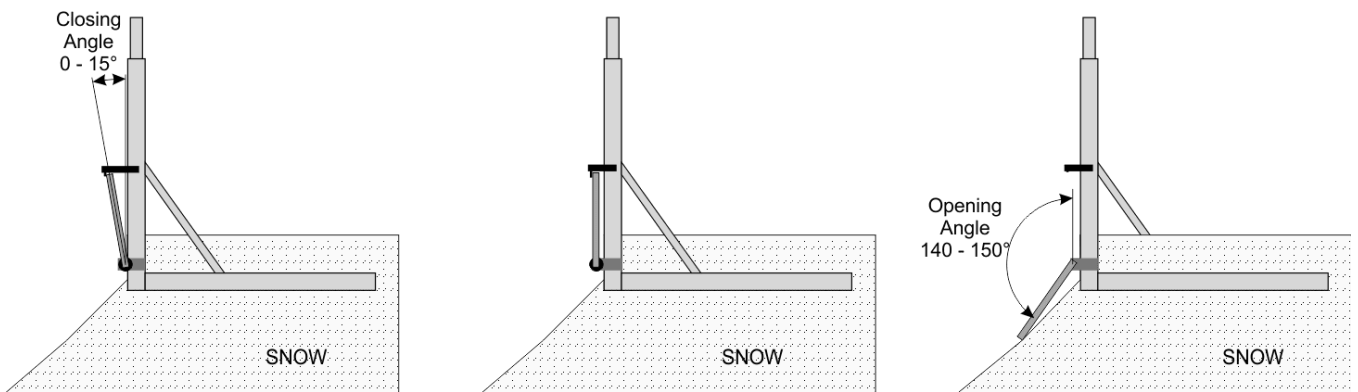
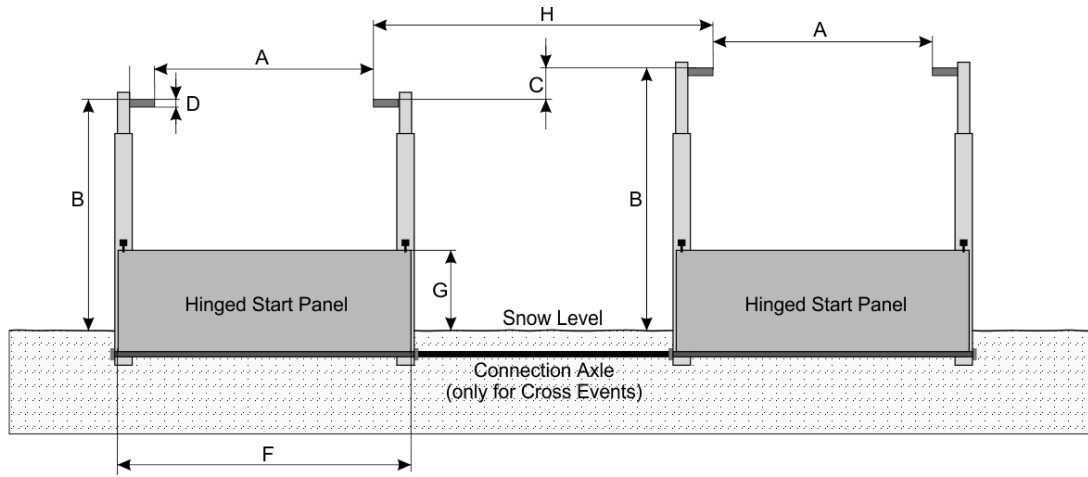

Installation for parallel races and team events has to follow the plan below:

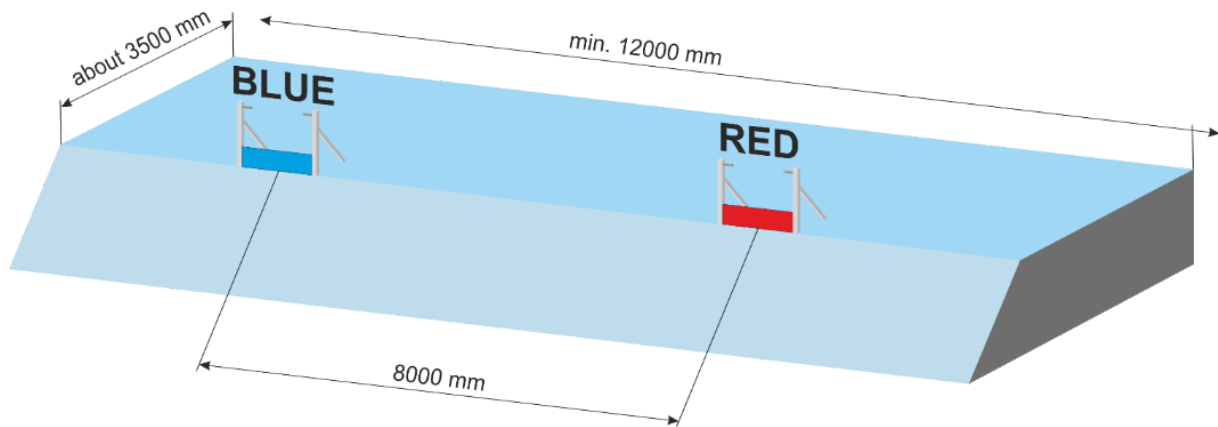

16.5. Photo Cell

Install photocells in close co-ordination with the Technical Delegate and/or the Race Jury. It is strongly recommended that the approach to the finish and the width of the line be made as levelled as possible, making it impossible for athletes to slide under or jump over the beams when installed.

Only wooden posts with a maximum diameter of 6 cm should be used to mount the photocells at the finish. You should cut the wood posts so they can break away in case of being struck by a racer. This cut must be made facing uphill. All brackets and elements of the photocells should be placed on the downhill side of the post. If photocells for intermediate are used, they should be mounted on hinged poles that will break away.

Photocell system A and B must always be completely separate (separate case and mounting brackets).

For photocells appropriate protection must be provided by the organiser.

Only photocells homologated by FIS are allowed to be used for the finish (see section of [homologated timing equipment](#171-list-of-homologated-timing-equipment) in this booklet or on FIS website).

There are two categories of cells:

1. Reflector Type:

The reflector-type photocell has the transmitter and receiver electronics in the same case. A simple reflector on the opposite side of the finish line is used to reflect the photocell beam back to the main unit. For System A and B the reflectors should be on the same side.

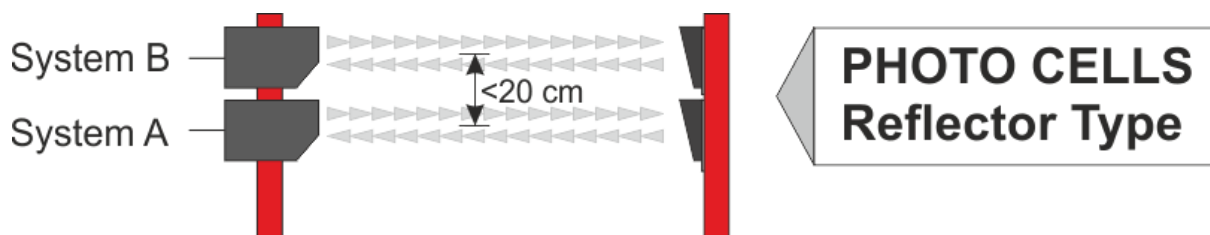
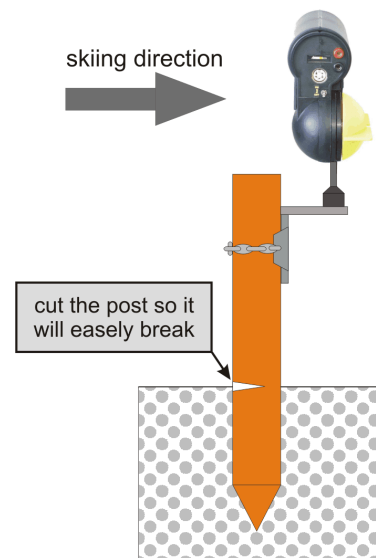

2. Transmitter-Receiver Types:

In this case the transmitter is on one side of the finish, and the receiver is on the other side. For System A and B transmitters can either be on opposite sides or on the same side.

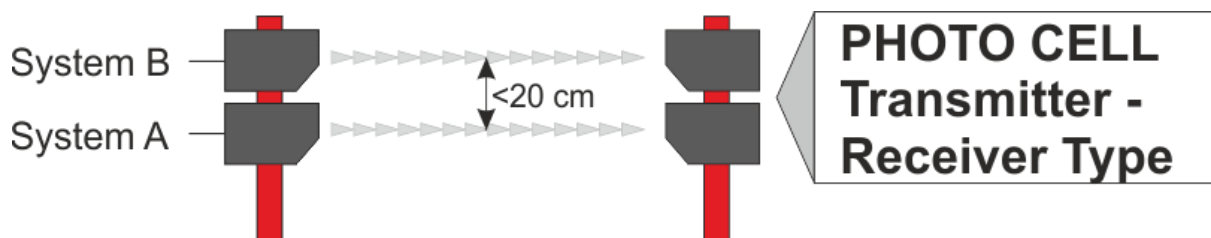

16.5.1. Photo Cells for the Finish

It is necessary to have two independent sets of photocells for the finish, one connected to Timing System A and one for Timing System B. The cells must be mounted so that both beams are triggered at a height that is lower than the knee of racers at the finish. It is recommended that the lowermost photocell be connected to Timing System A.

The photocells must be set up parallel to the finish on top of each other. Either the same post or two separate posts for both photocells can be used. The maximum vertical separation of the beams may not exceed 20 cm (8"), and in all cases should be less than that if possible.

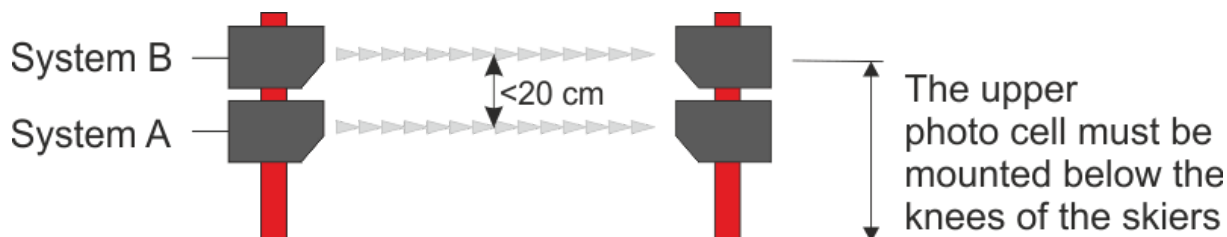

For the Transmitter-Receiver Type the transmitters of the photocell can be either on the same side or opposite side (see manufacturer specifications). The beams may be installed in a crossed configuration but in all cases the 20cm maximum vertical separation must be observed.

The photocells must be connected to the timing devices by fixed cable. No radio transmission of photocell signals to the timers is allowed for the finish photocells.

16.5.2. Photo Cells for Intermediate Time

There is no requirement to have a backup (System B) photocell for the intermediate time.

If you use photocells install them in close co-ordination with the Technical Delegate and/or the Race Jury.

To avoid the photocells (if used) being triggered by anyone other than the competitors, it is recommended that the person responsible for that intermediate timing point use a push-button to arm the photocells only when a competitor crosses the line.

16.5.3. Technical Specifications for the Photo Cell

The technical concept of the photocell is not restricted by FIS, although it must be assured that the photocell cannot be influenced by any other light, camera flash/strobes, radio waves (EMI) or mobile reflectors for photocells of reflector type.

The photocell must meet the standards for electronic devices in the country that it is sold.

Accuracy	<p>Sensing Time - The time delay from the instant the photocell is triggered to moment an output impulse is generated may not exceed 0.005 sec.</p> <p>Repeatability (Random Jitter) - The delay of impulses must be constant, the range must be less than 5/10.000 sec. This range is measured in a "peak-to-peak" manner, minimum to maximum extremes, it is not averaged.</p>
Operating Distance	<p>The photocell must work over a minimal distance of 20 m. The maximum size of the reflector (if used) is 100 mm (in all directions).</p>
Triggering Object	<p>An 8 mm object moving with a speed of 10 km/h is not allowed to trigger the photocell (measured at a distance of 2 m from lens of the receiver).</p> <p>A 100 mm object moving with a speed of 200 km/h must trigger the photocell (measured at a distance of 2 m from lens of the receiver). The object must be a black cylinder.</p>
Temperature Range	<p>-20 to +60°C (for colder weather you should prepare a cover so the photocell will still work).</p>
Power Supply	<p>If the photocell is supplied power from the timing device (within the same cable as the impulses) it needs no external power supply. If a battery is used as the power supply (external or internal) the Photocell must work for four (4) hours at -20°C.</p>
Reflector	<p>max. size is 10 cm (in all directions)</p>
For homologation of photocells	<p>When sending photocells to the FIS for homologation, the photocell needs an input contact to switch the photocell transmitter off, in order to make precise tests.</p>

16.6. Photo Finish Systems

A photo finish system can be used to determine a competitor's finish time. A photo finish system is a line scan camera that scans the finish line with an adjustable scan rate. The photo finish must be synchronized with the System A and System B timers.

In the case of a failure of System A and System B, and where the competitor's finish has been recorded by the photo finish system, this finish time must be used in the place of hand timing. The finish time of the photo finish must be used without any correction.

The photo finish time is taken when any part of the competitor's body crosses the finish line. The photo finish result is only to be provided to the jury.

For night races using a photo finish a light with min. 2000 Lux is necessary. If possible, the light should be without bright and dark phases. LED light is recommended.

All photo finish systems must meet the following criteria for use in FIS Alpine races:

Timer	The timer must be able to operate in Time-of-Day mode and be synchronized with all timing devices.
Operation Temperature	The photo finish camera must operate (once it is started) at ambient temperatures from -10° to +60°C.
Measuring Range	Time of day mode must be possible in hours, minutes, seconds and 1/1000, or better.
Timer Precision	Must measure 1/10000 second or better in time of day mode. Timer accuracy must be below +/- 10 PPM at a device temperature from -10° to +60°C.
Quartz	Ageing of the quartz must be below +/- 3 PPM per year. With an adjusted quartz frequency, the time drift must be below +/-0.5 PPM at 23°C.
Impulse Triggering	The delay of impulses is not allowed to be higher than 1/1000 sec. for the same channel (the channel is triggered from a reference impulse device in minute intervals). The delay of impulses must be constant; the range must be less than 1/10000 sec.
Timing Channels	The timing device needs a minimum of one timing channel for time of day synchronisation.
Synchronisation	It must be possible to synchronize the timing device with other timing devices.

Image Production	The photo finish system must scan the finish line at a minimum of 2000 scans per second and show images sequentially and show scanned finish line images in sequential order on a monitor screen and store it on a memory device. The vertical resolution must be at least 1000 pixels.
Image Evaluation	The photo finish system must be capable of showing the time of day for each line scan image.
Power Supply	Backup power supply must be granted for a minimum of 20 minutes (e.g. internal battery or external UPS).
Electromagnetic	The timing device must meet the standards of IEC (International Electronic Commission). This means the timing device must function satisfactorily in its electromagnetic environment without introducing intolerable electromagnetic disturbances to anything in that environment.

17. Homologation of Timing Equipment

The homologation of timing equipment is always valid for 5 years. If there are no rule changes to homologation of the timing equipment will be extended every year. In case of changes the homologation will expire within 5 years.

Manufacturers wishing to have their timing devices, start gate, photocells or photo finish system homologated for use in FIS races must send a request to the Timing Working Group through the FIS office which will instruct the manufacturer to provide all technical information indicated above. Software for photo finish systems is not part of the homologation. The costs of homologation must be paid by the manufacturer.

If a manufacturer homologates prototypes the FIS will not consider it for homologation. Only final versions of a device (as it is sold in public) will be homologated by the FIS.

Attention: All temperatures for the specification of timing equipment are given with a tolerance of $\pm 1^{\circ}\text{C}$.

17.1. List of Homologated Timing Equipment

The List of homologated timing equipment is not included in the timing booklet anymore. Please check this list on FIS webpage.

<https://www.fis-ski.com/en/inside-fis/document-library/timing-data>

18. Conclusion

We hereby wish to thank all members of the “FIS Timing Working Group” who have always used every endeavour to realize this “FIS GUIDE” for their Technical Delegates and event organisers. Our progress since 1996 reflects the balance between accepting new technologies and ensuring the correct evaluation of human performance through fundamental timekeeping concepts.

We wish to acknowledge the major contributions of participating manufacturers, FIS professionals and volunteers from our many members National Associations and race organisers who give so much of their time and expertise without which it would be impossible to generate such a document or perspective.

The FIS is pleased to support such a unique group in the world of timekeeping regulation and notices the absence of similar structures in many other high-performance sports that rely so heavily on timing technology for fair and impartial judgement.

We are fully aware that there are still some imperfections in these rules and descriptions and would welcome any constructive proposal as the work proceeds. This document will be continually revised to improve the knowledge of the FIS community for the benefit of all Alpine Skiing and Para Alpine Skiing competitions.

Please contact us with your suggestions and comments:

Member	E-mail
Daniel Defago (FIS – Chairman)	defago@fis-ski.com
Ulf Seehase (FIS)	seehase@fis-ski.com
Uldis Brize (FIS)	brize@fis-ski.com
Raphaël Blanchard (SUI)	Raphael.Blanchard@swisstiming.com
Ted Savage (CAN)	tsavage@precisiontiming.com
Albert Vetter (AUT)	albert@alge-timing.com
Federico Gori (ITA)	fgori@microgate.it
Tommy Jauhojärvi (FIN)	tommy@emit.no

19. Document Control

Sources Drawings

ALGE-TIMING GmbH, Austria
Swiss Timing LDT, Switzerland

Version 2.60

Section	Description
Page 7	Synchronisation: elimination of "one contact" for sync impulse
Page 13	Sketch for Level 2 (text for timing device at start - system B)
Page 14	Sketch for Level 3 (text for timing device at start - system A & B)
Page 26	Start Clock: Homologation needed for season 2022/2023

Version 2.61

Section	Description
Page 10	Timing without cable connection between start and finish
Page 14	Changes in the Set-Up Diagram Level 2 (Cable)
Page 15 - 22	Set-up diagram level 3 – new sketches for level 3
Page 23	Set-up diagram for parallel competitions level 0 and 1 (new sketch)
Page 24 + 25	Set-up diagram for parallel competitions level 2, 3 and 4 (new sketch)
Page 30	EET Calculation – attachment for Parallel Events
Page 36	Timers: "Impulse Triggering" and "Memory"
Page 41	Start Clock: Homologation date for start clock is removed (no homologation is planned right now)
Page 41	Start Clock: "Interface" and "Timer Precision"
Page 50	Photo Finish Systems: "Image Production"
Page 51	Homologation of timing equipment – now 5-year min. homologation

Version 2.62

Section	Description
Page 3	YOG - Youth Olympic Winter Games" is in level 3 (before in level 1)
Page 16 - 17	Set-up diagram level 3
Page 20 - 22	Set-up diagram level 3
Page 28	ICR Rule 611.3.2.1 changed
Page 37	16.1.1. Text changed, added permanent external synchronisation

Version 2.63

Section	Description
Page 6	Transponder
Page 34	Link to the "Timing Report"
Page 41	Acoustic Countdown, min. 100 dB
Page 53	List of Timing Working Group members was updated

Version 2.64

Section	Description
Page 6	Transponder
Page 6	Synchronisation
Page 14 - 22	Timing Sketches Revised
Page 41	Start Clock: min. 100 dB at 1 m measured

Version 2.65

Section	Description
Booklet	Corrected British spelling and grammar
Page 13 - 25	Timing Sketches Revised
Page 35	Power Supply: the text was corrected
Page 48	Reflector: "diagonal" replaced with "in all directions"
Appendix	Synchro diagram added

Version 2.66

Section	Description
Booklet	Incorporated Para Cross-Country corrected typos and quirks Converted the booklet to Markdown as the document base editorial adjustments

Version 2.67

Section	Description
Timers	Power Supply: requirements updated Operation Temperature: removed asterisk

20. Appendix

20.1. Synchro setup diagrams

