

Timing Booklet

Cross-Country Nordic Combined Para Cross-Country

Specifications, procedures and guidelines for timing in FIS Cross-Country, Nordic Combined and Para Cross-Country

Document

Timing Booklet Cross-Country, Nordic Combined, Para Cross-Country

Version

11

Date

2026-06-16

Author

FIS Timing Working Group

Table of Contents

1. General	6
1.1. References to race level classifications in Cross-Country	7
1.2. References to race level classifications in Nordic Combined	8
1.3. References to race level classifications in Para Cross-Country	8
1.4. Level Notes	9
2. Electronic timing	10
2.1. Timing devices	10
2.2. Timing support systems	11
3. Procedures	12
3.1. Synchronisation	12
3.2. Competition in progress	12
3.3. Missed Time	13
3.4. Visual Impaired Para Competitions	13
3.5. Timing Report	13
4. Equipment Set-Up (see drawing)	14
4.1. Cable connection	14
4.2. Start and Finish	14
5. Timing	17
5.1. Overview by event	17
5.2. Determination of times	17
5.2.1. Level 0	17
5.2.2. Level 1	18
5.3. Hand Timing	19
6. Timing & Data Technical Report	20
7. Criteria for FIS Approved Timing Devices in Cross-Country/Nordic Combined/Para Cross-Country	21
7.1. Timers	21

7.2. Timers with permanent external Synchronisation	23
7.3. Start Gate	24
7.3.1. Setup	24
7.3.2. Technical Specifications for Start Gates	25
7.4. Photocell	27
7.4.1. Installation	27
7.4.2. Photocell types	27
7.4.3. Photocells for the Finish	28
7.4.4. Technical specifications for the photocell	29
7.5. Photo finish systems	30
7.5.1. Definition and usage photo finish camera	30
7.5.2. Installation photo finish and video camera system	31
7.5.3. Technical specifications for the photo finish camera	32
7.6. Start clock	33
7.6.1. Technical specifications for the start clock (only interval start)	34
7.6.2. Cross Country Interval start	35
7.6.3. Cross Country Handicap start	35
7.6.4. Nordic Combined Gundersen start	35
8. Other timing support systems	36
8.1. Transponder system	36
8.2. Start system	36
8.2.1. Electronic start gun/system	36
8.2.2. Noise detector for start guns	36
8.3. Heat start gate	36
8.3.1. Heat start gates with photocells	37
8.3.2. Heat start gates with wand	38
8.4. Video control system	39
8.4.1. Start	39
8.4.2. Finish	39

9. Timing without cable connection between start and finish	40
10. Set up examples	42
10.1. Level 0 –Interval / Sprint Qualification Start	42
10.2. Level 0 – Sprint Final	43
10.3. Level 0 – Mass Starts	44
10.4. Level 0 – Cross-Country Pursuit / Nordic Combined Gundersen Start	45
10.5. Level 1 – Interval / Sprint Qualification Start	46
10.6. Level 1 – Sprint Final	47
10.6.1. Timer A + B, Photocells A + B, Photo finish	47
10.6.2. Timer A, Photocells A, Photo finish	48
10.6.3. Photo finish A + B	49
10.7. Level 1 – Mass Starts	50
10.7.1. Timer A + B, Photocells A + B, Photo finish	50
10.7.2. Timer A. Photocells A, Photo finish	51
10.7.3. Photo finish A + B	52
10.8. Level 1 – Cross-Country Pursuit, Nordic Combined Gundersen Start	53
10.8.1. Timer A + B, Photocells A + B, Photo finish	53
10.8.2. Timer A. Photocells A, Photo finish	54
10.8.3. Photo finish A + B	55
10.9. Level 1 – Interval Start (wireless)	56
10.10. Level 1 – Mass Start (wireless)	57
11. Important ICR rules for Timing in Cross-Country	58
12. Important ICR rules for Timing in Nordic Combined (Cross-Country)	60
13. Important ICR rules for Timing in Para Cross-Country	63
14. Homologation of Timing Equipment	65
14.1. List of Homologated Timing Equipment	65
15. Conclusion	66
16. Document Control	67
Sources drawings	67

Version 1 (November 2018)	67
Version 2 (October 2019)	67
Version 3 (October 2020)	67
Version 4 (October 2021)	68
Version 5 (October 2022)	68
Version 6 (November 2022)	68
Version 7 (October 2023)	69
Version 8 (October 2024)	70
Version 9 (October 2025)	70
Version 10 (June 2026)	71
Version 11 (June 2026)	71
17. Appendix	72
17.1. Synchronisation procedures	72

1. General

For all competitions listed in the FIS Calendar, electronic timing devices homologated by FIS must be used. Electronic timing will always be supplemented by hand-timing as a backup system and the results cross-checked between the two systems. Competitions using timing equipment other than those on the homologated device list might not be considered for FIS points in Cross-Country or results might not get valid in Nordic Combined.

The most updated list of homologated devices can be found at the FIS website (see [article 14.1](#)).

1.1. References to race level classifications in Cross-Country

Category	Description	Level
OWG	Olympic Winter Games	0
WSC	FIS World Ski Championships	0
WC	FIS World Cup	0
WJC	FIS Junior World Championships	0
U23	U23 World Championships	0
ANC	Australian New Zealand Cup	1
BC	Balkan Cup	1
COC	Continental Cup	1
EC	European Cup	1
EEC	East European Cup	1
EYOF	European Youth Olympic Festival	1
FEC	Far East Cup	1
NAC	Nor-Am Cup	1
FESA	FESA Cup	1
SAC	South American Cup	1
SC	Slavic Cup	1
SCAN	Scandinavian Cup	1
UST	US Super Tour	1
UVS	Universiade	1
YOG	Youth Olympic Winter Games	1
NC	National Championships	1
FIS	FIS Race	1
JUN	Junior Race	1
ROLWC	Roller Skiing World Cup	1
ROLSWC	Roller Skiing Stage World Cup	1
ROLWSC	Roller Skiing World Championships	1
ROLJWC	Roller Skiing Junior World Cup	1
ROLJWC	Roller Skiing Junior Stage World Cup	1
ROLWJC	Roller Skiing Junior World Championships	1
ROL	Roller Skiing	1
ROLJ	Roller Skiing Junior	1
ROLAC	Roller Skiing Asian Cup	1
ROLASC	Roller Ski Asian Championships	1
NJC	National Junior Championships	1
ML	Popular Races	1
MC	Marathon Cup	1
WL	World Loppet	1
WLC	World Loppet Cup	1
CIT	CIT	1
CISM	Military and Police	1
UNI	University Race	1
CHI	Children	1
MAS	Masters	1

1.2. References to race level classifications in Nordic Combined

Category	Description	Level
OWG	Olympic Winter Games	0
WSC	FIS World Ski Championships	0
WC	FIS World Cup	0
WJC	FIS Junior World Championships	0
COC	Continental Cup	1
EYOF	European Youth Olympic Festival	1
GP	Grand Prix	1
FESA	Alpen Cup	1
UVS	Universiade	1
YOG	Youth Olympic Winter Games	1
WCB	World Cup B	1
NC	National Championships	1
FIS	FIS Race	1
JUN	Junior Race	1
CHI	Children	1
YC1	Youth Cup I	1
YC2	Youth Cup II	1

1.3. References to race level classifications in Para Cross-Country

Category	Description	Level
PWG	Paralympic Winter Games	0
WSC	FIS World Championships	0
WC	FIS World Cup	0*
COC	Continental Cup	1**
UVS	Universiade	1**
FIS	FIS	1**
NC	Open National Championships	1**
ROL	Roller Ski	1**

* Level 1 requirements of this timing booklet are permissible for this category, using level 0 when possible

** Level 1 requirements should be adhered to on a best-effort basis for this category

1.4. Level Notes

Timing devices and cabling of a higher category can also be used.

Example: Level 1 can use same timing devices and cabling as Level 0.

2. Electronic timing

One of the following electronic timing technologies must be used to identify the official finish times:

- Electronic timing system based on photocells.
- Photo finish system

2.1. Timing devices

System A Timer

Level 0: Start and finish must be connected by cable

System B Timer

Level 1: Start and finish can be connected by cable or without cable connection.

Timing devices without direct cable connection to the main timing system must be connected to a timing device at the start or finish.

Radio connections are not allowed.

The use of any electronic device (e.g., optocoupler) between start gate and timer or photocell and timer must be specifically compatible and authorized by the manufacturers.

All timers always need to be synchronized.

Manual hand timing

In all cases for all events at all levels, hand timing is mandatory. Hand timer, with or without printers, showing times to at least 1/100th second should be synchronized to the time of day and used at the start and at the finish.

A backup video control system for checking the arrival should be used.

The manual hand timing must be done direct at the start line or finish line (direct sight to the start device or finish line).

Photo finish camera (line scan camera)

A photo finish system (line scan camera) with synchronized time of day mode used as timing device or tie determination at the finish line.

Transponder

are not determined to be used as official time (for system A and B)

Start clock

Use of such a start clock is highly recommended for all interval start races and mandatory at event Level 0; including Para Level 0 events, even when following the reduced Level 1 timing requirements.

A display board must be used for Cross-Country Pursuit and Nordic Combined Gundersen starts for each start lane. (CC ICR 315.4.4, NC ICR 515.2.7)

Start clock must show time of day and count down.

2.2. Timing support systems

Transponders

Transponders (active systems) can be used as a supporting system to the official timing system to determine race times and ranking sequences at intermediate timing points, pre-timing points and finish (unofficial result).

The official result has always to be confirmed by using FIS homologated timing devices.

Video finish camera

Determination of the finish order at the finish line.

Recommended are video camera systems with minimum 100 frames per second or higher and HD resolution (720p or higher).

3. Procedures

3.1. Synchronisation

All elements of the timing installation must be installed and be in good working order at least one hour before the beginning of the competition.

System A and B synchronisation to local Time of Day (ToD) must occur prior to the announced start of the 1st or only run and come from one single source impulse for all timing devices. One minute after synchronisation is done, an impulse must be sent by the same single source to check ToD synchronisation accuracy on Systems A and B. The maximum allowed difference between system A and B after one minute since initial synchronisation is 0.001 seconds.

Discrepancies observed that are greater than 0.001 after one minute require the synchronisation to be redone and checked again prior to the start of the 1st or only run. Start Clocks, hand timing and any other timing devices must be synchronised with system A and B timers prior to the run.

Synchronisation of the timing systems must occur as close as possible to the scheduled start for the first run or only run of the day. It is highly recommended this not be more than 30 minutes before the start. Synchronisation of all systems must be maintained throughout each run. Timers must not be re-synchronised during any run.

Illustrations of synchronisation procedures can be found in the [annexes](#).

3.2. Competition in progress

In case of timing problems, the chief of timing must inform members of the jury or the finish referee immediately.

Starter and official timekeeper should agree upon using specific terms and commands during communication. This dialogue should be short and precise, as well as systematically repeated for each competitor. In all cases it is recommended that the starter always informs the timekeeper(s) at the finish before and after a competitor leaves the start.

At the end of each race or competition, before sending out the competition results, times from the timing systems and the computer results system must be compared and cross checked for accuracy.

3.3. Missed Time

A missed time is a time of day that is not shown on the printed tape of the system A timer. If a time from system B is missed but you have it printed on system A it is not considered as a missed time.

In case you have a missed time of system A and must replace it by time of day of system B or of a hand time, then you must recalculate the missed time (see article 5.3).

3.4. Visual Impaired Para Competitions

In visually impaired para competitions, the guide may cross the finish line either before or after the athlete, in accordance with competition rules. Timing must always be recorded on the athlete's finish, not the guide's. It is recommended that a video control system, ideally a homologated photo-finish camera, be used to verify the correct finish time. In addition to the use of a photo-finish camera, it is recommended that guides wear transponders, even when not required. When both the athlete and the guide carry transponders, the correct identification of the athlete's finish time can be more easily facilitated. Result outputs must reflect the athlete's finish time only.

3.5. Timing Report

At the end of the competition, it is compulsory to send electronically the "Timing & Data Technical Report Form" to the FIS (see section [Timing & Data Technical Report Form](#) in this booklet). The printed tapes from the System A, System B and all hand timing records must be handed to the race organization who must keep it at least 3 months after the competition or after any appeal dealing with timing.

A member of the Timing Working Group could check at any time and at any race the timing system connection. A contact of each starting line and finish photocell must be available to connect a FIS timing device. Of course, such connection will be done at least 2 hours before the race starts and not during the race.

4. Equipment Set-Up (see drawing)

4.1. Cable connection

For events of level 1 timing without cable connection from the start is permitted for both A and B timing systems (see [art. 9. Timing without cable connection between start and finish](#)). Refer to set-up diagrams that describe in detail how this may be affected.

Attention: The cable dedicated to timing functions must be reserved for that purpose only and must be protected from any interference (e.g., speaker systems, snow gun data, etc.). No technical changes during the competition that may alter the transmission of trigger signals (length, capacitance, resistance, etc.) may be affected. The organiser must ensure that cable conduits and other cable runs do not interfere with timing cable functions. It is highly recommended that expert technical testing and verification of these timing cables be performed to assure timing cable integrity.

4.2. Start and Finish

Start gate (interval start)	Minimum of 2 electronically isolated contacts activated by 1 wand. Timing wires must be connected to separate start gate contacts using separate connectors. The wand must be installed so that starting is impossible without it opening.
Heat start gates (heat starts)	Electronic or mechanical start gate by start lane with optical indication of a false start either on the gate or control interface. Mandatory for use at event Level 0. Not applicable for Para Cross-Country.
Start clock	Must show time of day, countdown status and can have acoustic signal (5 seconds countdown). Must be synchronized with the other timing systems. Use of such a start clock is highly recommended for all individual start competitions and is mandatory for use at event Level 0. Indicates the start gap 3 sec. before and after the start signal with green and red lights (Level 0) A display board with time of day must be used for each start lane in pursuit and Gundersen competitions showing time of day. Count down sound is not mandatory.
Voice communication	Timing impulse and voice communication functions can be separated on different wire pairs. If radios are used for voice communication, a dedicated channel must be used. For interval starts voice communication over cable is recommended.

Timing cables

Make sure that cables cannot be torn out at the start by a competitor, or by any other person next to the starting area.
Optical Cables: If a converter is necessary between timing cables and optical cables, then the converter must be approved by the FIS.

Photocells at the finish line

Please refer to the attached section that explains photocell use.
Wire must be used to connect photocells to the timer. Wireless is not allowed.

Photo finish camera

Installation on a stable tripod or fixed construction in alignment to the photocell detection line. The organiser should provide a stable platform for tripod installation.
The photo finish system should be used in time of day mode.
The photo finish system power should be secured by an UPS for a minimum of 20 minutes.
The photo finish system must work at ambient temperatures from -10° to +60°C.

Video camera

Installation on a stable tripod or fixed construction in alignment to the photocell detection line.
The video system power should be secured by an UPS for a minimum of 20 minutes.
The photo finish system must work at ambient temperatures from -10° to +60°C.

Start gun noise detector / electronic start gun / start signal system

System which either detects an acoustic start signal or trigger an electronic noise as start signal and gives an electronic start impulse to the timing system.
The start system must be installed in a way that every competitor at the start can hear the acoustic start signal loud and clear.
The start system must work at ambient temperatures from -20° to +60°C.

Photocells installation

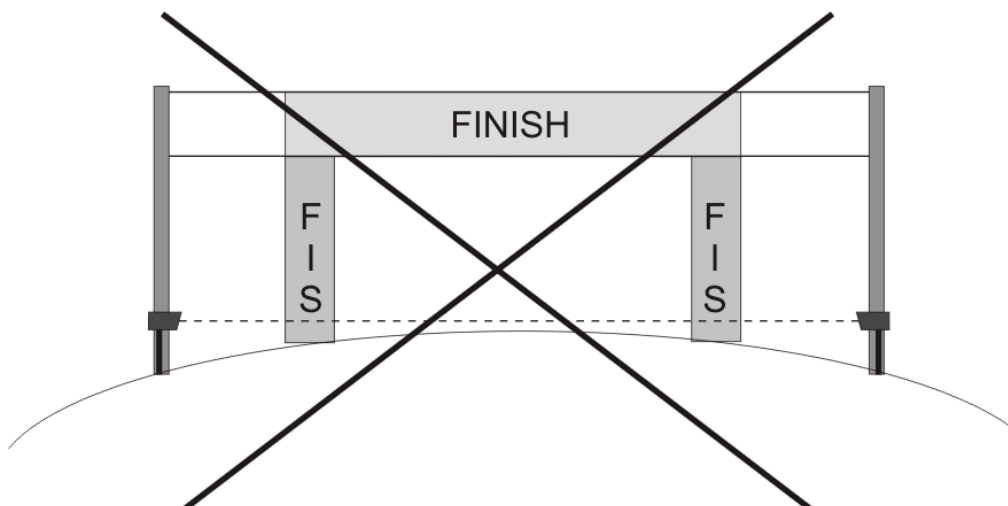
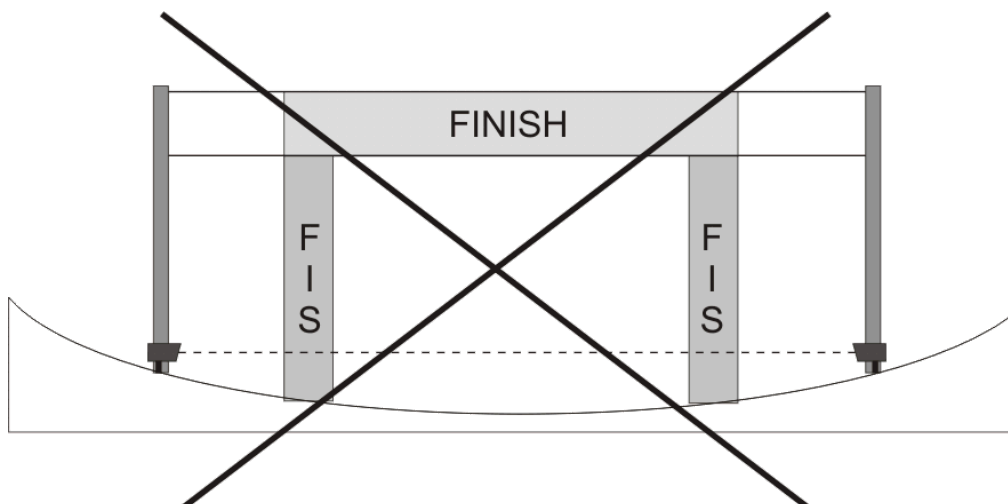
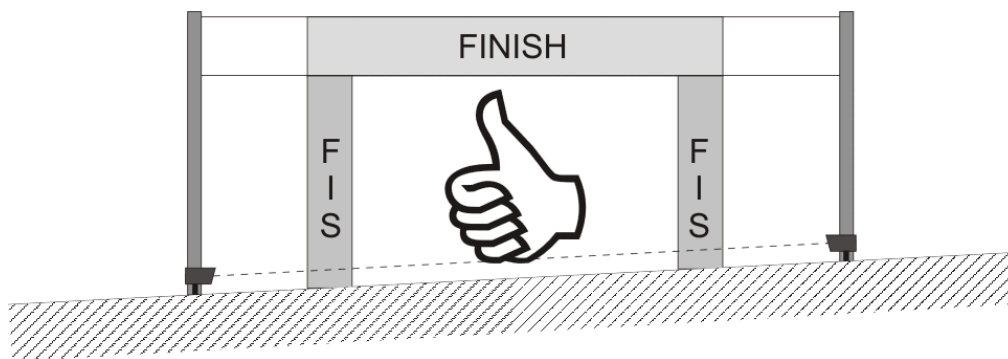

5. Timing

5.1. Overview by event

	Interval Start	Sprint Qualification	Sprint Finals	Mass Start	CC Pursuit / NK Gundersen Start	Team Sprint
Result time precision	1/10s	1/100s	1/100s*	1/10s	1/10s	1/100s
Time recording precision (TOD)	1/10000s or higher					
Start system A+B	Start gate		Start signal-based start system	Display board with time of day		Start signal-based start system
Backup start	Hand time					Hand time
Finish System A+B	Photocell Photo finish		Photo finish Photocell + Video finish			
Backup finish	Photo finish Photocell + Video finish Transponder Hand time					
Connection to the start	Level 0: Cabled connections only (exception for races with having start and finish on different locations with long distance in-between) Level 1: Cabled connections and connections without cable					

* For level 0 result times must be available in 1/1000th to determine lucky loser between different heats

5.2. Determination of times

5.2.1. Level 0

Interval Start and Sprint Qualification:

- Photocell or photo finish camera time is used as official finish time.
- In case of close finish line passing of 2 or more athletes, times are checked and (if necessary) corrected with the photo finish camera.

Sprint Finals:

- Transponder passing times are considered as unofficial times, as they can guarantee a resolution of $\leq 1/100$ s only. Outputs to the real time outputs (MIS, TV, SCB, Internet) are produced in $1/10$ s. After verification and correction with the photo finish system, it is extended to $1/100$ s ($1/1000$ s for Lucky Loser).
- In case of ties and in case of very little finish time difference of two or more athletes (< 0.075 s), the real time output is "PHOTO FINISH" instead of the time.
- In order to determine the correct ranking and exact finish time ($1/1000$ s), photo finish must be used for all athletes. Unofficial transponder passing times are verified and corrected with the photo finish times and marked as official.

Mass Start, Pursuit, Gundersen and Team Sprint:

- Photocell or photo finish camera time is used as official finish time.
- In case of ties and in case of very little finish time difference of two or more athletes (< 0.075 s), the real time output is "PHOTO FINISH" instead of the time.
- Photo finish system is used to solve the tie.

5.2.2. Level 1**Interval start and Sprint Qualification:**

- Photocell or photo finish camera time is used as official finish time

Sprint Finals:

- Photocell or, photo finish camera times are considered as official times, as they can guarantee a resolution of $\leq 1/100$ s only
- In case of ties and in case of very little finish time difference of two or more athletes (< 0.075 s), photo finish system or video camera is used to solve the tie.

Mass Start, Pursuit, Gundersen and Team Sprint:

- Photocell or photo finish camera time is used as official finish time.
- In case of ties and in case of very little finish time difference of two or more athletes (< 0.075 s), photo finish camera or video system is used to solve the tie.

5.3. Hand Timing

If the electronic timing temporarily fails, hand times will be used by correcting the average time difference which develops between the electronic timing and the hand-timing. If the electronic timing fails frequently or completely during the competition, the hand times will be used for all the competitors. When hand times are used to calculate results, the actual start times must be used.

6. Timing & Data Technical Report

The FIS provides free of charge a software to fill out the "Timing & Data Technical Report". The software can be downloaded from FIS website in Timing & Data subsections:

<https://www.fis-ski.com/inside-fis/general-fis-documents/timing-data>

The software downloads are available for Windows and macOS.

With the electronic timing report the timekeeper can send the report independently from the TD to the FIS. The timekeeper must fill all the fields required for each event and sends the report as XML file.

The FIS only accepts the Timing & Data Technical Reports that are sent as XML file. Printed reports sent by mail, fax or e-mail will not be accepted.

A detailed documentation of the Timing Report software can be found on the FIS website Timing & Data section or within the Timing Report software.

7. Criteria for FIS Approved Timing Devices in Cross-Country/Nordic Combined/Para Cross-Country

All timing devices must meet the following criteria for use in FIS Cross-Country and Nordic Combined races must be approved by FIS and must respect the FIS rules.

7.1. Timers

Timer	<p>The timing device must have an internal printer or external printer (e.g., RS232, RS422, USB, Ethernet, WLAN, Bluetooth). Printing through a computer is not allowed. The timer must be able to operate in Time-of-Day. The output of the time must always have the same precision (e.g., printer, display and interface).</p>
Printer	<p>This printer must print at least in a chronological order the time of day. For each printed time of day there must be an indication of the timing channel. If it is possible to do manipulation or correction of times in the timer the printer must mark such a corrected time.</p>
Interface	<p>The timing device needs an interface (e.g., RS232, RS422, USB, Ethernet, WLAN, Bluetooth) to connect a PC and transfer the data for data processing (result service) online. The communication protocol must be forwarded to the FIS for the homologation test.</p>
Power Supply:	<p>The timing system must work with both, internal batteries, and external power. The timing system must work without power supply from the mains for one (1) hour at 23°C with one printout per minute, two (2) hours at – 10°C with one printout per minute and 30 minutes of warmup to 60°C with one printout per minute.</p>
Operation Temperature	<p>The timing device and printer must work at ambient temperatures from –10° to +60°C</p>
Measuring Range	<p>Time of day mode must be possible in hours, minutes, seconds and 1/10000, or better.</p>
Timer Precision	<p>Must measure 1/10000 second or better in time-of-day mode. Timer accuracy must be below +/- 10 PPM at a device temperature from –10° to +60°C.</p>

Quartz	Ageing of the quartz must be below +/- 3 PPM per year. The time drift must be below +/-0.5 PPM at a constant temperature of 23°C.																
Impulse Triggering:	The delay of impulses is not allowed to be higher than 1/1000 sec. for the same channel (the channel is triggered from a reference impulse device in minute intervals). If two channels are triggered at the same time the times must be within 1/1000 second. The delay of impulses must be constant; the gap between both channels must be max. 1/10000 sec.																
Timing Channels	The timing device needs a minimum of two independent channels, one for start and one for finish.																
Synchronisation	Synchronisation between main- (System A) and backup timer (System B) must be possible.																
Memory	The timing device needs an internal static memory that stores the time of day with the timing channel and manipulations. It must be possible to send the data of the memory in chronological order through an interface to another device (e.g. PC).																
Electromagnetic	The timing device must meet the standards of IEC (International Electronic Commission). This means the timing device must function satisfactorily in its electromagnetic environment without introducing intolerable electromagnetic disturbances to anything in that environment.																
Truncation	The truncation to 1/10 or 1/100 of seconds must be made after the calculation of the race time. The digits of the run time after the 1/10 or 1/100 are thrown away. Example 1/10s: <table border="0" style="width: 100%;"> <tr> <td style="width: 80%;">Start Time:</td> <td style="text-align: right;">10:00:00.102</td> </tr> <tr> <td>Finish Time:</td> <td style="text-align: right;">10:01:30.289</td> </tr> <tr> <td>Calculated race Time:</td> <td style="text-align: right;">1:30.187</td> </tr> <tr> <td>Time after truncation:</td> <td style="text-align: right;">1:30.1</td> </tr> </table> Example 1/100s: <table border="0" style="width: 100%;"> <tr> <td style="width: 80%;">Start Time:</td> <td style="text-align: right;">10:00:00.132</td> </tr> <tr> <td>Finish Time:</td> <td style="text-align: right;">10:01:30.259</td> </tr> <tr> <td>Calculated race Time:</td> <td style="text-align: right;">1:30.127</td> </tr> <tr> <td>Race Time after truncation:</td> <td style="text-align: right;">1:30.12</td> </tr> </table>	Start Time:	10:00:00.102	Finish Time:	10:01:30.289	Calculated race Time:	1:30.187	Time after truncation:	1:30.1	Start Time:	10:00:00.132	Finish Time:	10:01:30.259	Calculated race Time:	1:30.127	Race Time after truncation:	1:30.12
Start Time:	10:00:00.102																
Finish Time:	10:01:30.289																
Calculated race Time:	1:30.187																
Time after truncation:	1:30.1																
Start Time:	10:00:00.132																
Finish Time:	10:01:30.259																
Calculated race Time:	1:30.127																
Race Time after truncation:	1:30.12																

7.2. Timers with permanent external Synchronisation

For timing devices with permanent external synchronisation (e.g., GPS-Synchronisation) all specifications of "Timers" (see 7.1. Timers) are valid. Additionally, it must fulfil the following features:

- The permanent external synchronisation solution must have a constant accuracy from 0.0001s or better.
- The timing device must run independent with the internal quartz.
- The time synchronisation of the permanent external device can be in periodic intervals or permanent.
- If the difference between the internal timing (quartz) and the permanent external synchronisation is within an accuracy of +/-0.0003 seconds, it is allowed to resync the timing device with the external time.
- If the difference between the internal time (quartz) and the external time is higher than +/-0.0003 seconds, it is not allowed to resync the timer with the external time. From now on the timing device must run with the internal quartz only (no further resynchronisations are allowed).
- The printer of the timer must print a message when the permanent external synchronisation is switched off. The message must inform about the reason for switching the permanent external synchronisation off and the time when this happens.
- In case the permanent external synchronisation signal is lost the timer must print it a message. If the timer gets the synchronisation signal again further synchronisation is allowed if the time difference is within the allowed +/-0.0003 seconds.

7.3. Start Gate

7.3.1. Setup

Install the Start Gate in close coordination with the Technical Delegate and/or the Race Jury. Only Start Gates homologated by the FIS are allowed (see list on the FIS website).

The following elementary rules should be considered:

- Start Gate mounting post must be put into the ground or snow or firmly connected to a fixed structure under the snow. It is essential that the support post be solidly fixed and not permitted to move in any way.
- The Start Gate must likewise be attached to the mounting post without the possibility of rotation or movement of any kind.
- The height above the ground of the Start Gate must be such to permit the athletes to hit the bar below the knee not too close to the boot top. In all cases the range shall not be less than 35cm nor more than 50 cm above the snow surface at the start.
- The start gate may be placed either to the left or to the right of the starting skier, in all cases making sure that the angle of departure to the first gate ensures that the start gate must open.

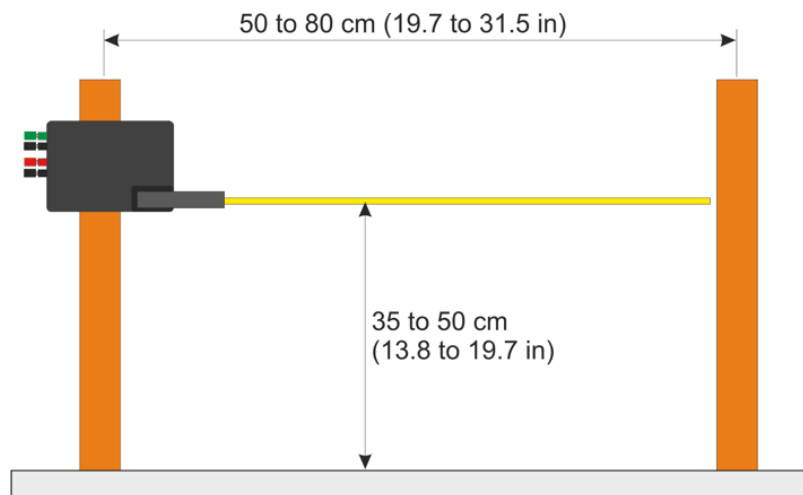

- The length of the wand (bar) must be within 50 cm (20 in) and 80 cm (31,5 in)
- The Start Gate must have two different and completely isolated lines, two separate connectors, one for timing system A and one for timing system B

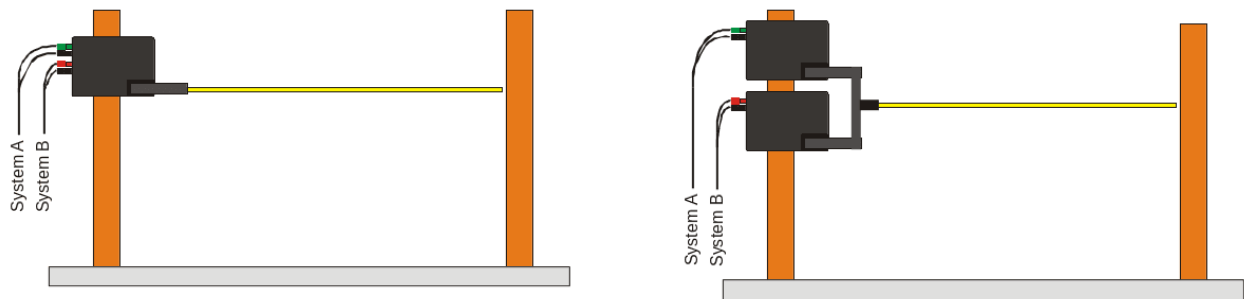

- If two Start Gates are used side by side, they must be solidly mounted on the same physical bracket and each arm must be stiffly connected together (both mechanism and box).
- Only the use of one wand (bar) is permitted.
- If the Start Gate must be replaced during the competition, it must be a Start Gate of the same type and manufacturer.
- The position of the Start Gate (both height and rotation) must be marked before the beginning of the competition to make sure that a replacement can be installed in the same position if necessary.

7.3.2. Technical Specifications for Start Gates

Only Start Gates that meet the following technical specifications will be homologated by the FIS:

- Contacts** The Start Gate shall provide a separate contact for system A and B. Each contact needs a separate, but identical switch. Both contacts must be completely electrically separated.
- Angular Range** Both impulses must be given at an angular range of the start wand between 10° and 30°, calculated from the closed position (when the wand is stiff). Starting gates that do not meet this trigger angle are not admitted.

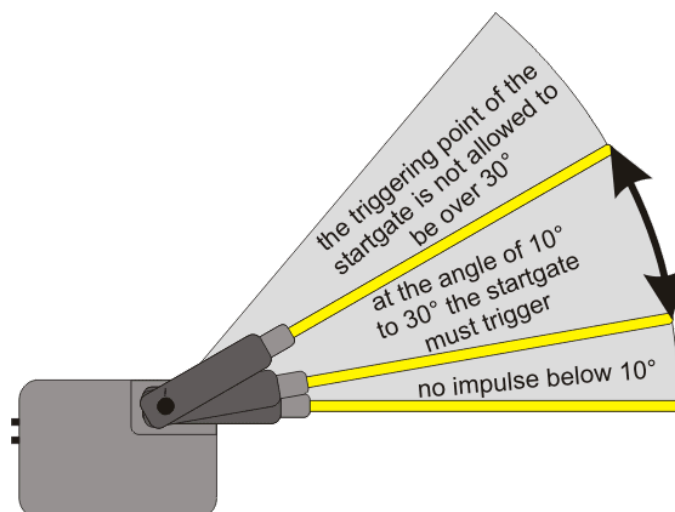

Angular Accuracy

Both impulses shall be given by starting gate switches of the same type with an angular accuracy of +/- 5° respect to the indicated rotation of the start wand.

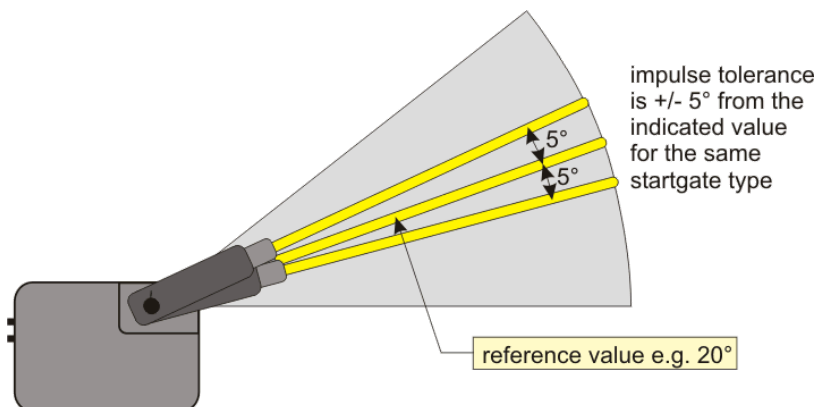

Start Wand

The start wand cannot be so stiff that it could cause injury and that it will not break. On the other hand, it must be as stiff as possible to avoid unfair starts. If you rotate the start wand at the far end, it is not allowed to bend more than 15° without causing the triggering mechanism to actuate. The wand must stay open once it is activated. Spring return “Self-Returning” mechanisms are not permitted. For Cross-Country an automatic rewinding start gate is allowed.



Start Gate Impulses

Two different possibilities are accepted:

- 1) **Single Shot:** the line is activated for predetermined time even if the wand remains open
- 2) **Continuous:** the line remains activated as long as the wand remains open.

7.4. Photocell

7.4.1. Installation

Install photocells in close co-ordination with the Technical Delegate and/or the Race Jury. It is strongly recommended that the approach to the finish and the width of the line be made as level as possible, making it virtually impossible for athletes to slide under or jump over the beams when installed.

The measuring point of the light or photo barrier must be at a height of 20-30 cm above the ground surface.

Wooden, plastic or metal posts with a maximum diameter of 6 cm or no larger than 6 cm x 6 cm should be used to mount the photocells at the finish. The posts should be installed so that they stand stable in or on the snow, far enough off the side of the course to ensure no contact between the racer and the photocell installation and can tip over or be struck by a racer.

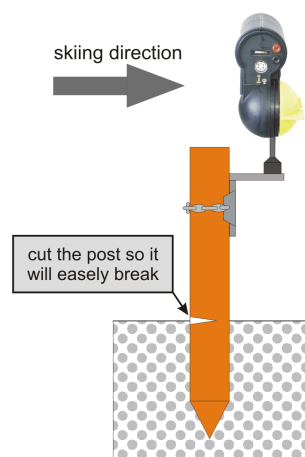

Photocell system A and B must always be completely separate (separate case and mounting brackets).

For photocells, appropriate protection must be provided by the organiser.

Only photocells homologated by the FIS are allowed to be used for the finish (see list on FIS website).

7.4.2. Photocell types

There are two categories of cells:

1. Reflector Type:

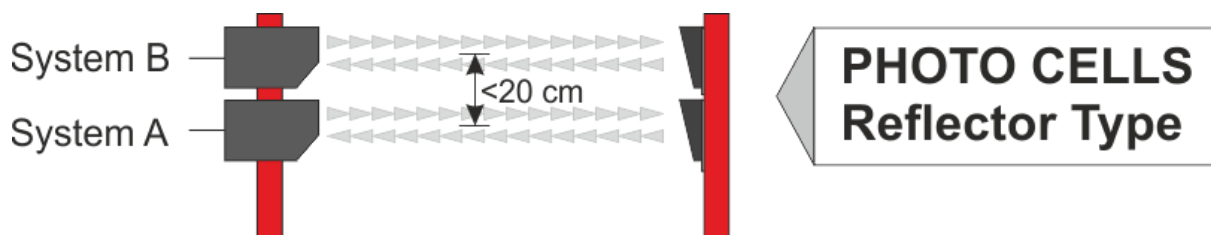

The reflector-type photocell has the transmitter and receiver electronics in the same case. A simple reflector on the opposite side of the finish line is used to reflect the photocell beam back to the main unit. For System A and B the reflectors should be on the same side.

2. Transmitter-Receiver Types:

In this case the transmitter is on one side of the finish, and the receiver is on the other side. For System A and B transmitters can either be on opposite sides or on the same side.

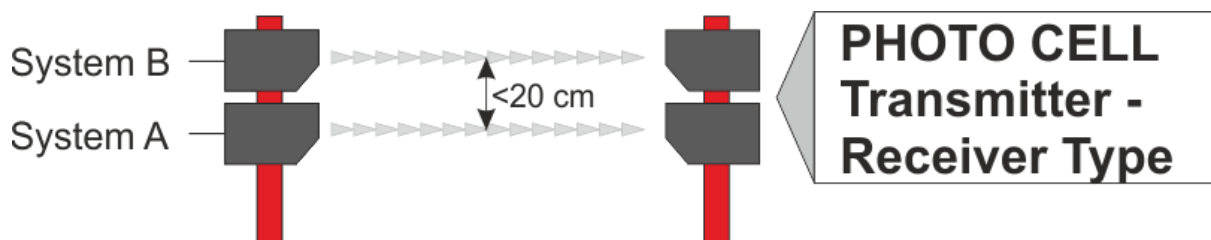

7.4.3. Photocells for the Finish

It is necessary to have two independent sets of photocells for the finish, one connected to Timing System A and one for Timing System B. The cells must be mounted so that both beams are triggered at a height that is lower than the knee of racers at the finish. It is recommended that the lowermost photocell be connected to Timing System A.

The photocells must be set up parallel to the finish on top of each other. Either the same post or two separate posts for both photocells can be used. The maximum vertical separation of the beams may not exceed 20 cm (8"), and in all cases, should be as close as possible.

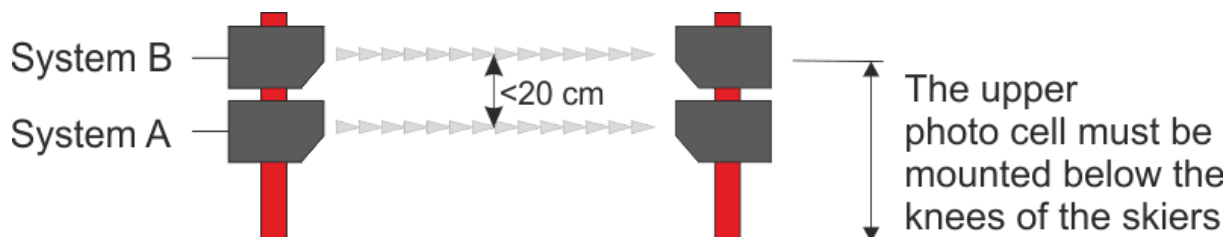

For the Transmitter-Receiver Type the transmitters of the photocell can be either on the same side or opposite side (see manufacturer specifications). The beams may be installed in a crossed configuration but in all cases the 20cm maximum vertical separation must be observed.

The photocells must be connected to the timing devices by fixed cable. No radio transmission of photocell signals to the timers is allowed for the finish photocells.

7.4.4. Technical specifications for the photocell

The technical concept of the photocell is not restricted by the FIS, although it must be assured that the photocell cannot be influenced by any other light, camera flash/strobes, radio waves (EMI) or mobile reflectors for photocells of reflector type.

The photocell must meet the standards for electronic devices in the country that it is sold.

Accuracy	<p>Sensing Time - The time delay from the instant the photocell is triggered to moment an output impulse is generated may not exceed 0.005 sec.</p> <p>Repeatability (Random Jitter) - The delay of impulses must be constant, the range must be less than 5/10.000 sec. This range is measured in a "peak-to-peak" manner, minimum to maximum extremes, it is not averaged.</p>
Operating Distance	The photocell must work over a minimal distance of 20 m. The maximum size of the reflector (if used) is 100 mm (in all directions)
Triggering Object	<p>An 8 mm object moving with a speed of 10 km/h is not allowed to trigger the photocell (measured at a distance of 2 m from lens of the receiver).</p> <p>A 100 mm object moving with a speed of 200 km/h must trigger the photocell (measured at a distance of 2 m from lens of the receiver).</p>
Temperature Range	-20 to +60°C (for colder weather you should prepare a cover so the photocell will still work).
Power Supply	<p>If the photocell is supplied power from the timing device (within the same cable as the impulses) it needs no external power supply.</p> <p>If a battery is used as the power supply (external or internal) the photocell must work for four (4) hours at -20°C.</p>
Delay trigger	A delay trigger (blocking time) of the photocell should be set according to manufacture specification.
Reflector	max. size is 10 cm (in all directions)
For homologation of photocells	When sending photocells to the FIS for homologation, the photocell needs an input contact to switch the photocell transmitter off, to make precise tests.

7.5. Photo finish systems

7.5.1. Definition and usage photo finish camera

A photo finish system is a line scan camera that scans the finish line with an adjustable scan rate (see manufacturer specifications). The photo finish must be synchronized with the System A and System B timers.

The photo finish system can be used to determine a competitor's finish time or solve ties in cases where other timing systems' time resolution cannot generate an unambiguous result.

In the case of a failure of System A and System B, and where the competitor's finish has been recorded by the photo finish system, this finish time must be used in the place of hand timing using a correction factor. The correction factor should be the difference between the time taken by the photo finish system and the electronic times of the 3 competitors before the missed time. The sum of the 3 times differences is divided by 3 which must be applied to the photo finish time of the competitor without an electronic time.

The photo finish time is taken when the toe of the first boot meets the finish line. The photo finish result is only to be provided to the Jury before the result is confirmed by the Jury.

Photo finish cameras must be used for all mass start races (Cross-Country Mass start, Pursuit, Skiathlon, Sprint final heats, Team Sprint, Relay and Nordic Combined Gundersen start, Mass start, Team Sprint, Team) in level 0. In level 0 two photo finish cameras are required installed on both sides of the finish line. In level 1 photo finish cameras are recommended but video systems can be used (see article [8.4.2](#)).

The setup of the scan rate of the photo finish camera should be according to the needs, the light condition, vertical resolution of pixel and the manufacture specification.

For night races using a photo finish camera a light with min. 2000 Lux is necessary. If possible, the light should be without bright and dark phases. LED light is recommended.

7.5.2. Installation photo finish and video camera system

For the installation of the photo finish system or video system a stable tripod or fixed construction should be used to mount the camera system.

The finish line should be set in 90° angle to the direction of the racecourse. All timing devices at the finish line should be aligned to the centre of the finish line. As a recommendation for the alignment of a photo finish system or video system the photocell detection line should be used.

The TD needs to check the alignment of the photo finish camera. The colour of the finish line (usually red) should be showing on the computer screen for the full width of the finish line.

The picture of a video system should cover the full finish line area.

A camera installation angle of 20° to the far end of the finish line is recommended.

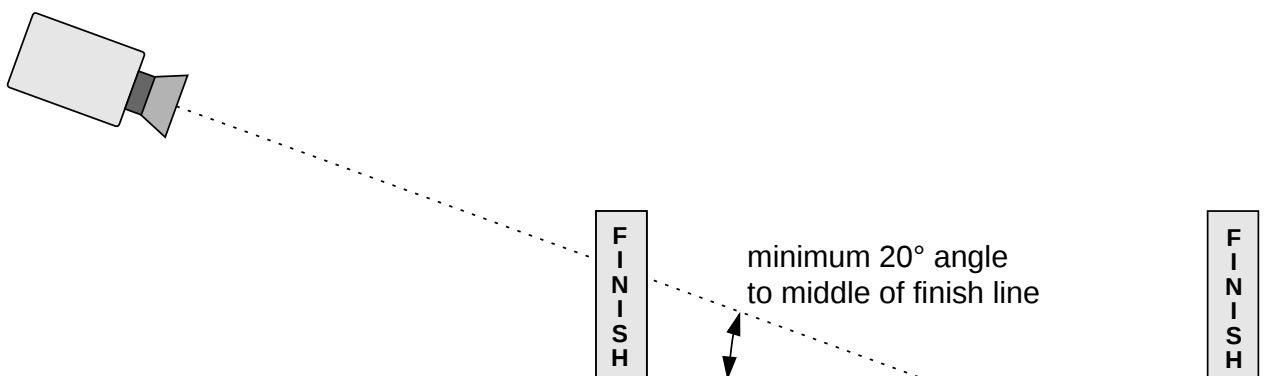

7.5.3. Technical specifications for the photo finish camera

All photo finish systems must meet the following criteria for use in FIS Cross-Country races:

Timer	The timer must be able to operate in Time-of-Day mode and be synchronized with all timing devices.
Operation Temperature	The photo finish camera must operate (once it is started) at ambient temperatures from -10° to +60°C
Measuring Range	Time of day mode must be possible in hours, minutes, seconds and 1/1000, or better.
Timer Precision	Must measure 1/10000 second or better in time of day. Timer accuracy must be below +/- 10 PPM at a device temperature from -10° to +60°C.
Quartz	Ageing of the quartz must be below +/- 3 PPM per year. Time drift must be below +/-0.5 PPM at a constant temperature of 23°C.
Impulse Triggering	The delay of impulses is not allowed to be higher than 1/1000 sec. for the same channel (the channel is triggered from a reference impulse device in minute intervals). The delay of impulses must be constant; the range must be less than 1/10000 sec.
Timing Channels	The timing device needs a minimum of one timing channel for time-of-day synchronisation.
Image Production	The photo finish system must scan the finish line at a minimum of 2000 scans per second and show images sequentially and show scanned finish line images in sequential order on a monitor screen and store it on a memory device. The vertical resolution must be at least 1000 pixels.
Image Evaluation	The photo finish system must be capable of showing the time of day for each line scan image.
Power Supply	Backup power supply must be granted for a minimum of 20 minutes (e.g., internal battery or external UPS).
Electromagnetic	The timing device must meet the standards of IEC (International Electronic Commission). This means the timing device must function satisfactorily in its electromagnetic environment without introducing intolerable electromagnetic disturbances to anything in that environment.

7.6. Start clock

A start clock is a device that helps the starter to organize the start. Use of such a start clock is highly recommended for all interval start and is mandatory at all Level 0 events; including Para Level 0 events, even when following the reduced Level 1 timing requirements.

The start clock indicates the start gap 3 sec. before and after the start signal (Level 0).

It must work in time-of-day mode.

For Cross-Country Pursuit and Nordic Combined Gundersen start a display board with time of day is sufficient and mandatory for all competitions.

7.6.1. Technical specifications for the start clock (only interval start)

Display	<p>The start clock has a visible display to the athletes. The display can be analogue or digital.</p> <p>Analogue Clock: The clock must be visible over a distance of at least 10 m</p> <p>Digital Clock: The figures must be visible over a distance of at least 10 m</p> <p>Time of day: hours, minutes and seconds (min. 3 digit)</p> <p>Countdown: minutes and seconds (min. 3 digit)</p> <p>Bib: to show the bib is not mandatory, but can be an option</p>
Start indicator light	The start clock must show if the start is free (green indicator) or not allowed (red indicator).
Acoustic Countdown	The start clock needs an acoustic countdown. The acoustic countdown has at least one beep at each second during the last five seconds (low tone from five seconds to 1 second and high tone at zero).
Sound Level	The acoustic signal emitted by the device must be capable of producing a sound level of at least 100 dB when measured at a distance of 1 meter from the device, 1 meter above ground.
Countdown	The start clock needs to support each start interval used on the start list.
Power Supply	<p>The start clock must work without power supply from the mains for eight (8) hours at 23°C and an interval of 1 min.</p> <p>The start clock must work without external power supply on internal batteries for 6 (six) hours at -20°C.</p>
Operation Temperature	The start clock must work at ambient temperatures from -20° to +60°C*
Measuring Range	Time of day mode must be possible.
Timer Precision	Timer accuracy must be below +/- 10 PPM at a device temperature from -10° to +60°C.
Quartz	<p>Ageing of the quartz must be below +/- 3 PPM per year.</p> <p>With an adjusted quartz frequency, the time drift must be below +/-0.5 PPM at 23°C.</p>
Impulse Triggering	The delay of impulses is not allowed to be higher than 1/1000 sec. for the same channel (the channel is triggered from a reference impulse device in minute intervals). The delay of impulses must be constant, the range must be less than 1/1000 sec.
Timing Channels	The timing device needs timing channels that allows the synchronisation of the device and output of the start impulse (zero tone, e.g. start impulse for timing device).
Synchronisation	Synchronisation with other timing devices must be possible.
Electromagnetic	The timing device must meet the standards of IEC (International Electronic Commission). This means the timing device must function satisfactorily in its electromagnetic environment without introducing intolerable electromagnetic disturbances to anything in that environment.

7.6.2. Cross Country Interval start

The start clock shows the time of day and a countdown to the next start. The official start time is given by an acoustic start signal. Additionally, the start clock can indicate with coloured indicator lights (e.g., green, red) the start time corridor (3 sec. before to 3 sec. after official start time) and gives a 5 second acoustic countdown signals. Acoustic start and countdown signals should be different in length or kind of sound.

7.6.3. Cross Country Handicap start

The handicap start is carried out without an electronic start gate. A video camera should be used to record the entire start such that a review by the Jury can be done. The video camera should record the start and time of day of a display board.

To guarantee an exact start, a large display board must be used for each starting lane together with bib number and starting times for respective competitors for that lane. The start must be prepared so that two or more competitors may start side by side.

7.6.4. Nordic Combined Gundersen start

The Gundersen start is carried out without an electronic start gate. To guarantee an exact start, a large display board must be used. The board is started by showing zero time when the first competitor starts. At the same time, the starters must start an additional stopwatch for control. The starting procedure must be recorded by a HD video camera which focused to the clearly marked starting line (see marking finish line, ICR 515.2.18). As a backup system for OWG, WSC, WC and WJC an additional transponder line must be placed 1,5 m beyond the starting line. The reference time for the Jury to check the start procedure is 1 second, which means all earlier starts must be checked.

8. Other timing support systems

8.1. Transponder system

The transponder system installation must be done according to the manufacture instructions.

Transponders (active systems) can be used as a supporting system to the official timing system to determine race times and ranking sequences at intermediate timing points, pre-timing points and finish (unofficial result).

The official result has always to be confirmed by using a FIS homologated timing system.

8.2. Start system

8.2.1. Electronic start gun/system

When the starter presses the button of the electronic start gun, they emit a signal to play a simulated gunshot or other acoustic start signal that is broadcasted to loudspeakers close to the start lanes, can show a flash (optional) and sends an electronic start impulse to the timing system.

The start system must be installed so that every competitor at the start can hear the acoustic start signal loud and clear at the same time.

8.2.2. Noise detector for start guns

A noise detection sensor is affixed to a regular start gun, which sends an electronic start impulse to the timing system upon firing.

8.3. Heat start gate

Electronic or mechanical start gate by start lane with optical indication of a false start either on the gate or control interface.

The usage in level 0 is mandatory.

Not applicable for Para Cross-Country.

8.3.1. Heat start gates with photocells

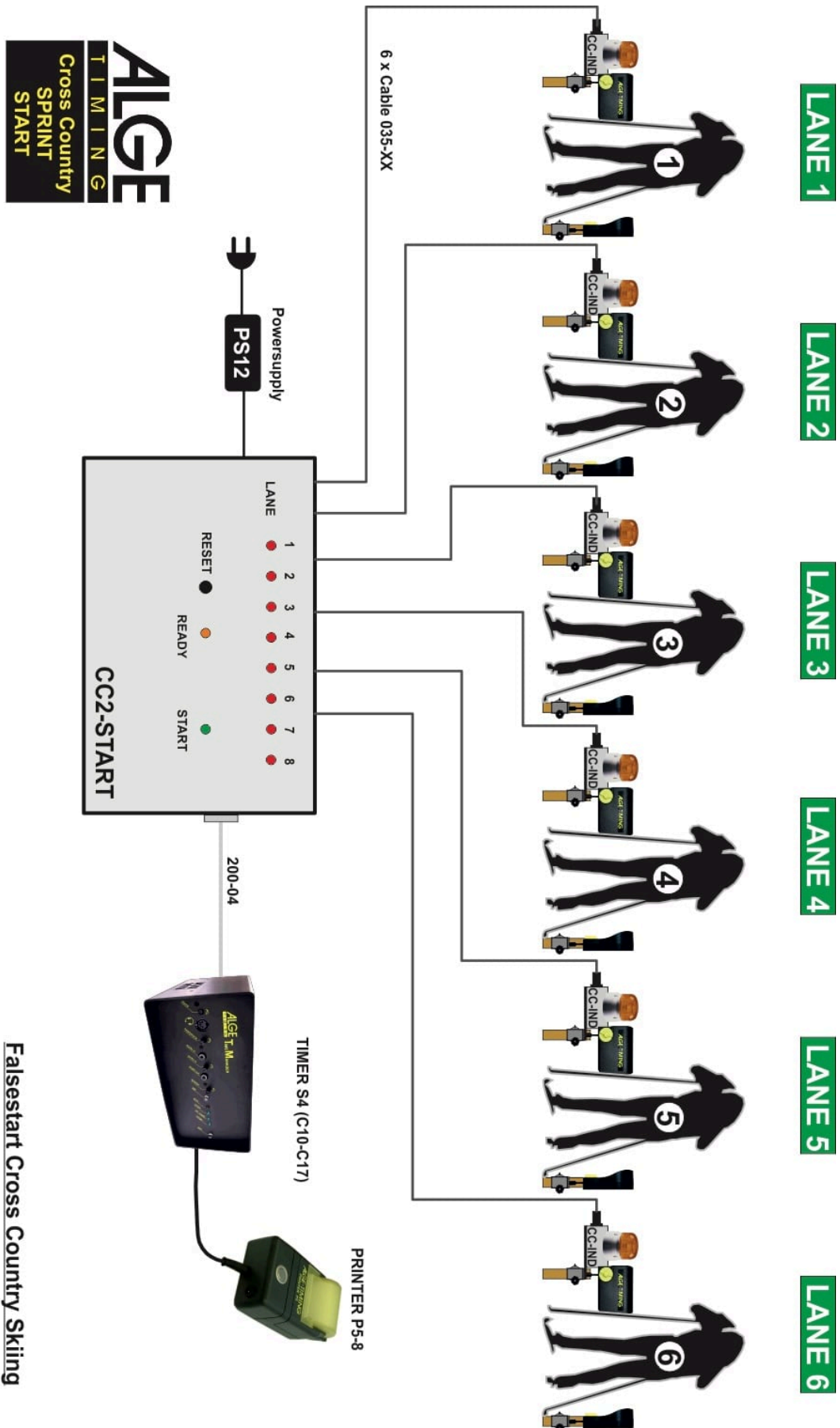

Falstart Cross Country Skiing

18.12.2015

8.3.2. Heat start gates with wand

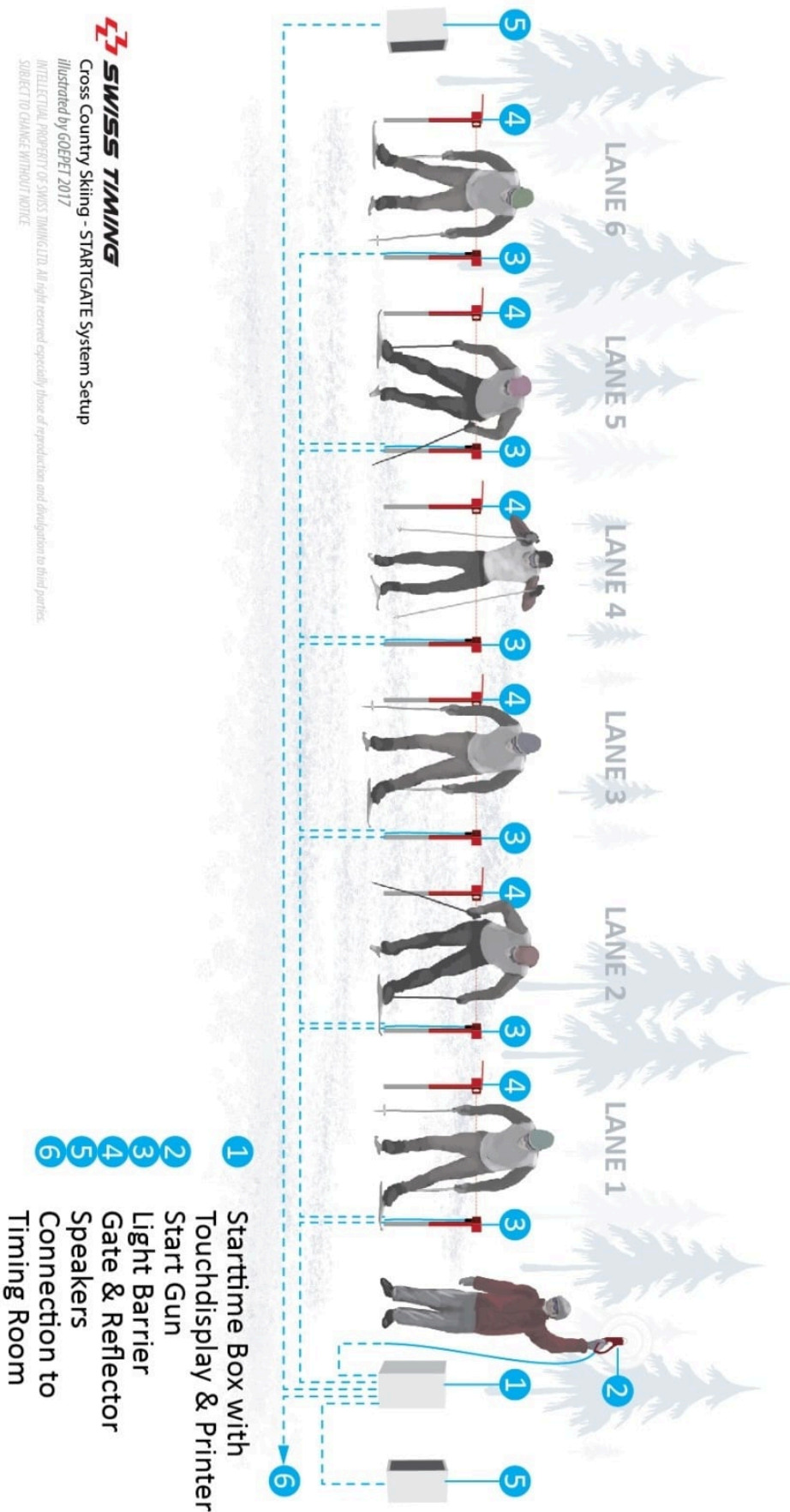

8.4. Video control system

A video control system is video camera system which records picture by picture. It is recommended to use HD video cameras (720p or higher) with at least 100 frames per seconds or higher. Video systems are not subjects to be homologated as timing device.

8.4.1. Start

Cross-Country Handicap Start:

A video camera should be used to record the entire start such that a review by the Jury can be done.

To support the recording of the start procedure a display board with time of the day can be set up so that the video control system also records the display with the reference time.

Nordic Combined Gundersen Start:

The starting procedure must be recorded by a HD video camera which focused to the clearly marked starting line (see start area, ICR 515.2.7).

To support the recording of the start procedure a display board with time of the day can be set up so that the video control system also records the display with the reference time.

8.4.2. Finish

The video system can be used to determine the order and starting bibs at the finish line or to solve tie. For determination of the competitor's finish time a homologated timing device must be used.

Nordic Combined

The finish is to be recorded by two video cameras. The first camera must be positioned on one the side of the finish line providing a picture of the finish and an additional camera positioned to identify the starting bibs.

9. Timing without cable connection between start and finish

The FIS Timing Working Group recognizes the importance of allowing emerging and technically responsible technologies to be used in modern FIS events. For this reason, and because of the flexibility that it affords, FIS Level 1 events may use timing solutions that do not require any hard wire connection between start and finish for either A and/or B systems. Level 0 events are not allowed to use this solution (exception for races with having start and finish on different locations with long distance in-between).

The FIS does not homologate wireless timing technology for use in FIS skiing events. The FIS certifies timing equipment (timers, start gates, photocells, other devices) for use with hard-wired connections between start and finish locations as a general standard.

Regardless of the technology being used, every solution without hill cable must include the use of homologated timers operating in synchronized Time-of-Day with active printers or data memory. Systems will be represented by homologated timer(s) at the start and homologated timer(s) at the finish. Please refer to the set-up diagram that illustrates the correct use of this technique.

All timing rules remain in force in this situation (set-up, synchronisation, time-of day precision, printing, hand timing). In addition, for race results to be valid the TD must gather and submit to FIS all timer printer tapes or data memory with the Timing Technical Report Forms. The “no-wires” aspect of this technique provides the time-of-day start times and the time-of-day finish times from the separate, synchronized timing devices. In all cases the start and finish sensors must still be connected to the start and finish timers using hard-wire connections.

The Chief of Timing must make sure that all wireless solutions adopted work in the physical environment of the start and finish regardless of the weather conditions and temperature.

This allows race organisers to use many types of timing solutions without wires as long as these timers are in place and are used to verify the results.

If times are generated by a timing solution other than system A or B in all cases these times must be checked against system A and must match exactly. In case results deviate from system A, the competition must be evaluated on the A system times as per the normal timing set-up rules and procedures.

When a radio system with impulse transmission is used, the accuracy must be consistent within +/- 1/1000 second. The accuracy must be clearly described in the manual of the radio system. FIS rules must be applied if a time from system B is used.

In practice the timing-without-wires solution must consider how to prove that times from all start and finish sensors are valid in the Time-of-Day ("ToD") methods normally used.

Thus, ANY additional wireless solution from ANY manufacturer that allows for comparison to these ToD start and finish times (recorded and preserved at each homologated timer) could be used. How the wireless transmission is achieved (impulse, data, GPS, Network, voice, paper) is open for use, but it must be able to match the ToD proof captured on the homologated devices at start and finish in ToD.

In all cases where no-wire solutions are used the timing tapes or data memory files must be sent with the results to the FIS. A description of techniques that demonstrate how the calibration issues between the time bases are dealt with over runs is also essential to be provided to FIS, since synchronisation could be an important element as evidence.

In all cases where wireless equipment will be used, it is highly recommended that Race Organisers or assigned FIS Technical Delegates check with a member of the FIS Timing Working Group in advance of the competition to describe the intended wireless equipment set-up and to verify test data.

Please refer to the set-up diagram that illustrates the correct use of this technique.

10. Set up examples

10.1. Level 0 –Interval / Sprint Qualification Start

Additional connections might be required for a proper service of the event.

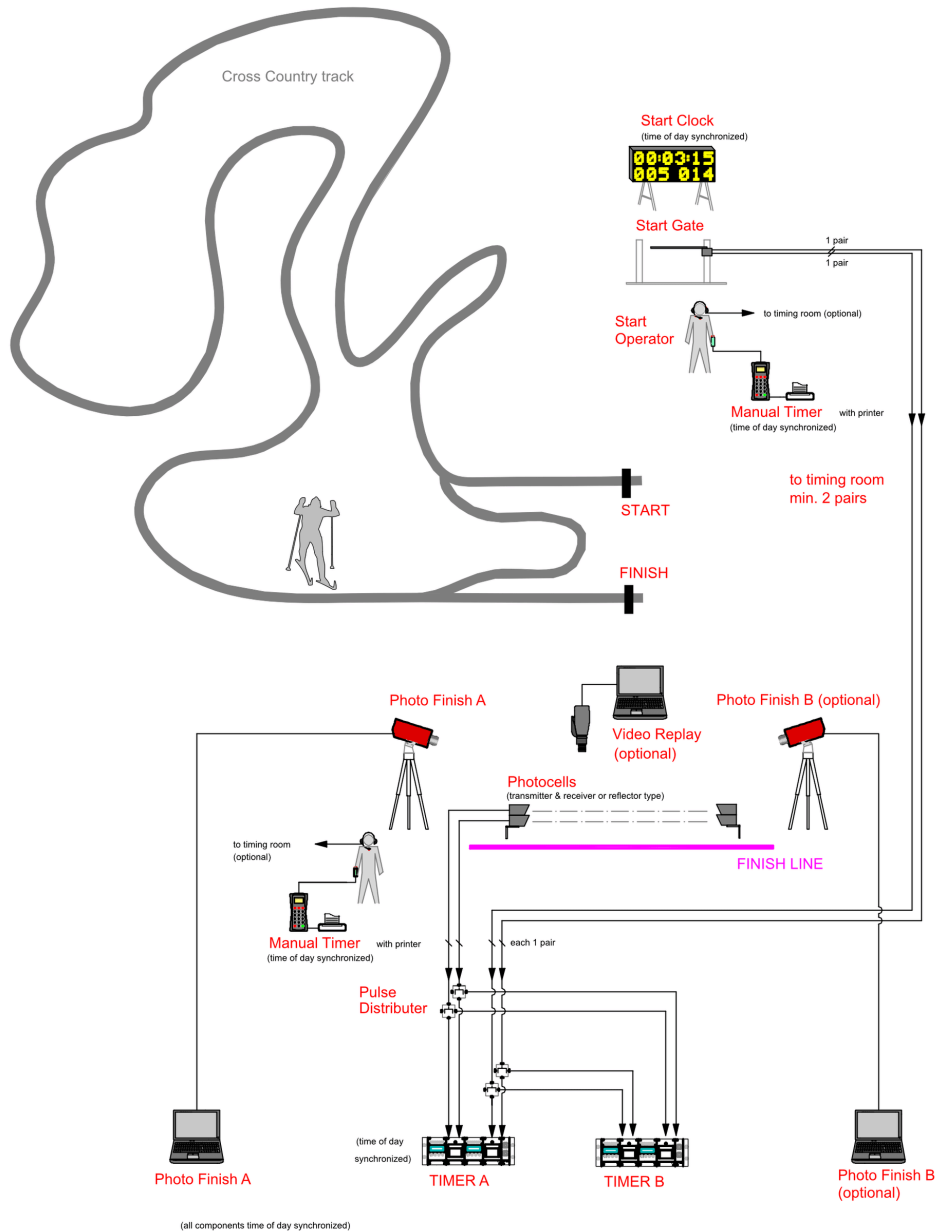

	Drawn by	Swiss Timing / Mis	Cross Country Skiing Timing System Level 0 Interval Start & Sprint Qualif.
	Date	30.10.2025	
	Proved by	Swiss Timing	
	Version	V007/INO	
	File name	tb_0009.ndw	
CC-FIS-Lv0 / IN 0		INTERNATIONAL SKI AND SNOWBOARD FEDERATION (FIS)	

10.2. Level 0 – Sprint Final

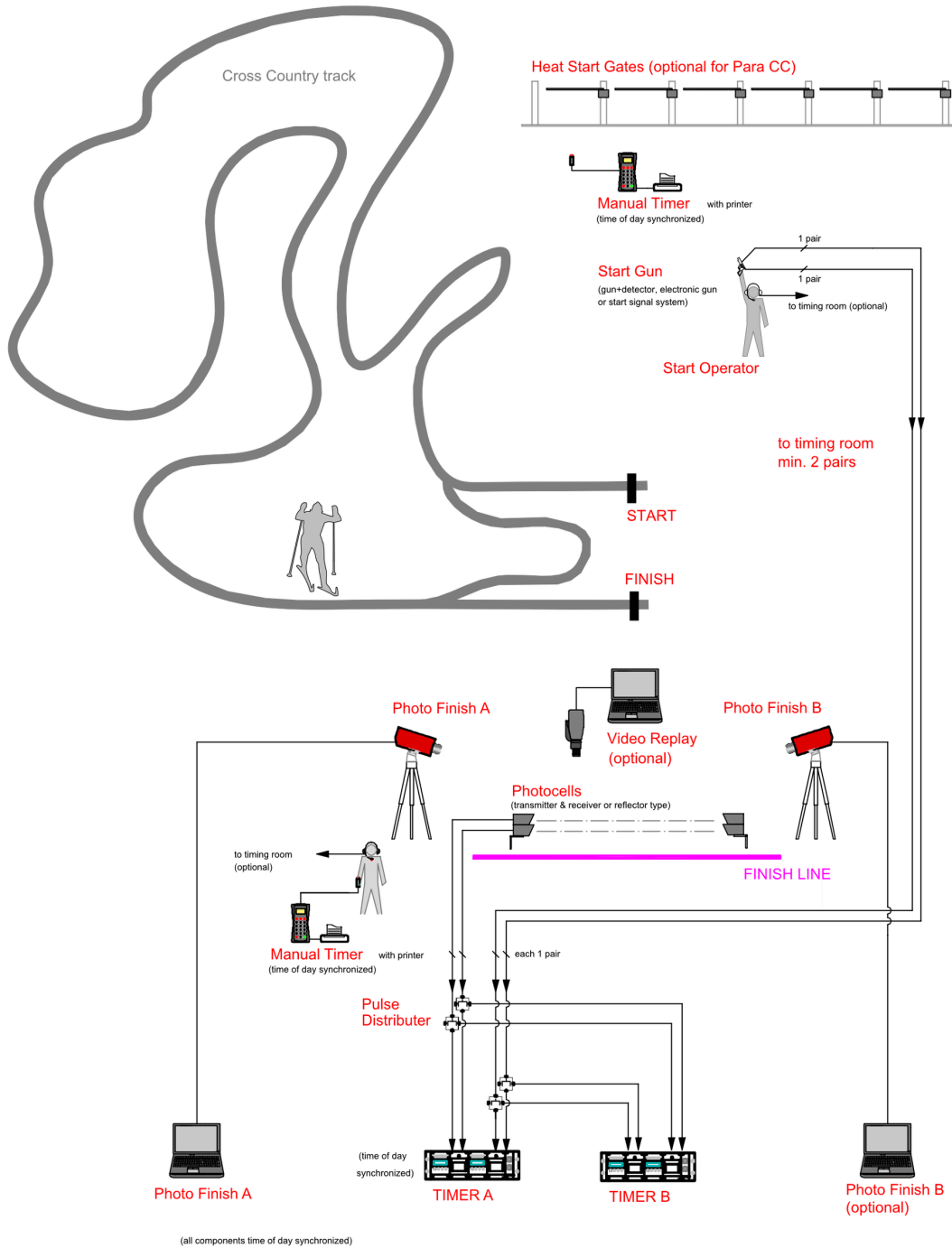

	Drawn by	Swiss Timing / Mis	Cross Country Skiing Timing System Level 0 Sprint Final's
	Date	19.04.2026	
	Proved by	Swiss Timing	
	Version	V008/SF0	
	File name	tb_0010.ndw	
CC-FIS-Lv0 / SF 0		INTERNATIONAL SKI AND SNOWBOARD FEDERATION (FIS)	

10.3. Level 0 – Mass Starts

Additional connections might be required for a proper service of the event.

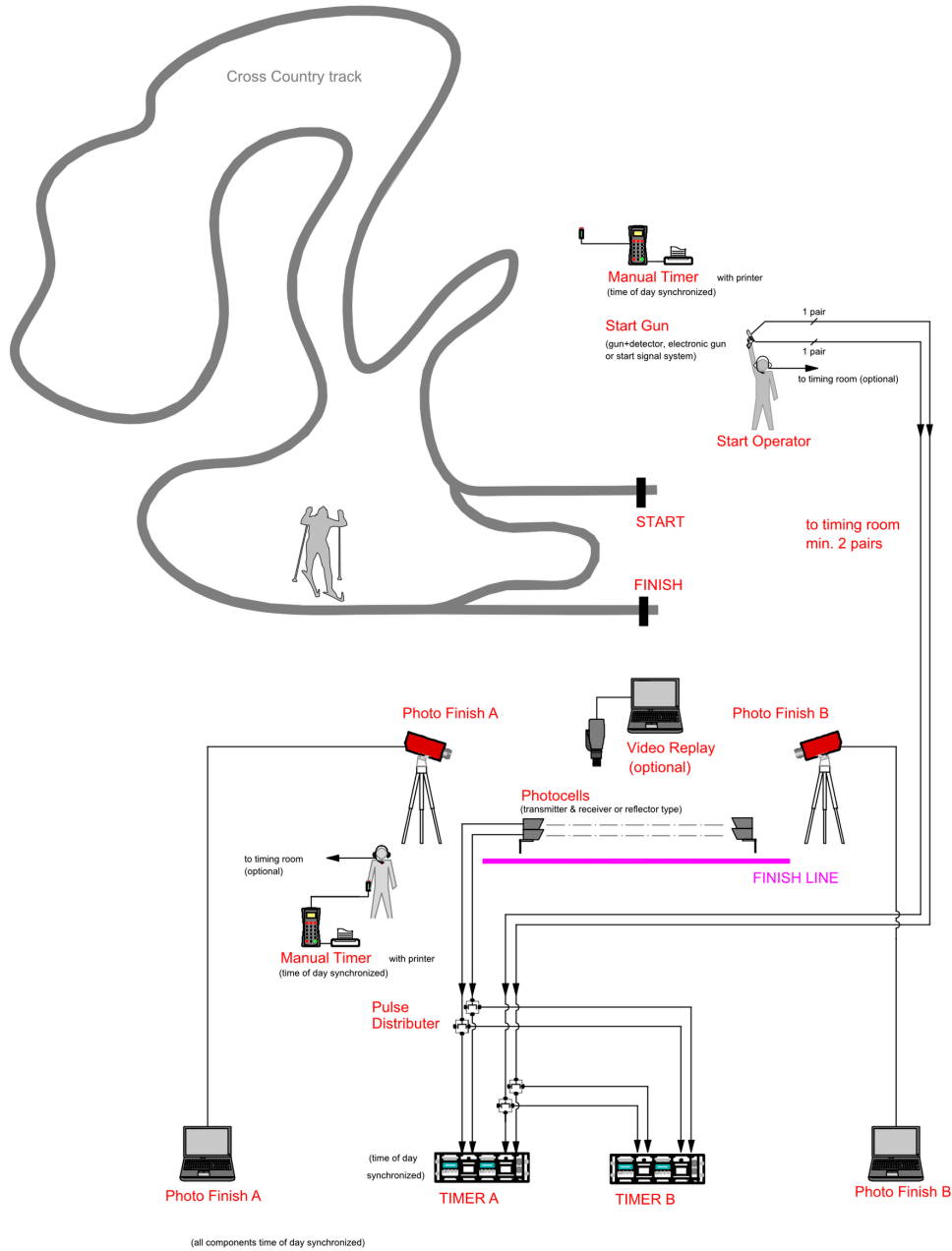

	Drawn by	Swiss Timing / Mis	Cross Country Skiing Timing System Level 0 Mass Start
	Date	30.10.2025	
	Proved by	Swiss Timing	
	Version	V007/MS0	
	File name	tb_0009.ndw	
CC-FIS-Lv0 / MS 0		INTERNATIONAL SKI AND SNOWBOARD FEDERATION (FIS)	

10.4. Level 0 – Cross-Country Pursuit / Nordic Combined Gundersen Start

Additional connections might be required for a proper service of the event.

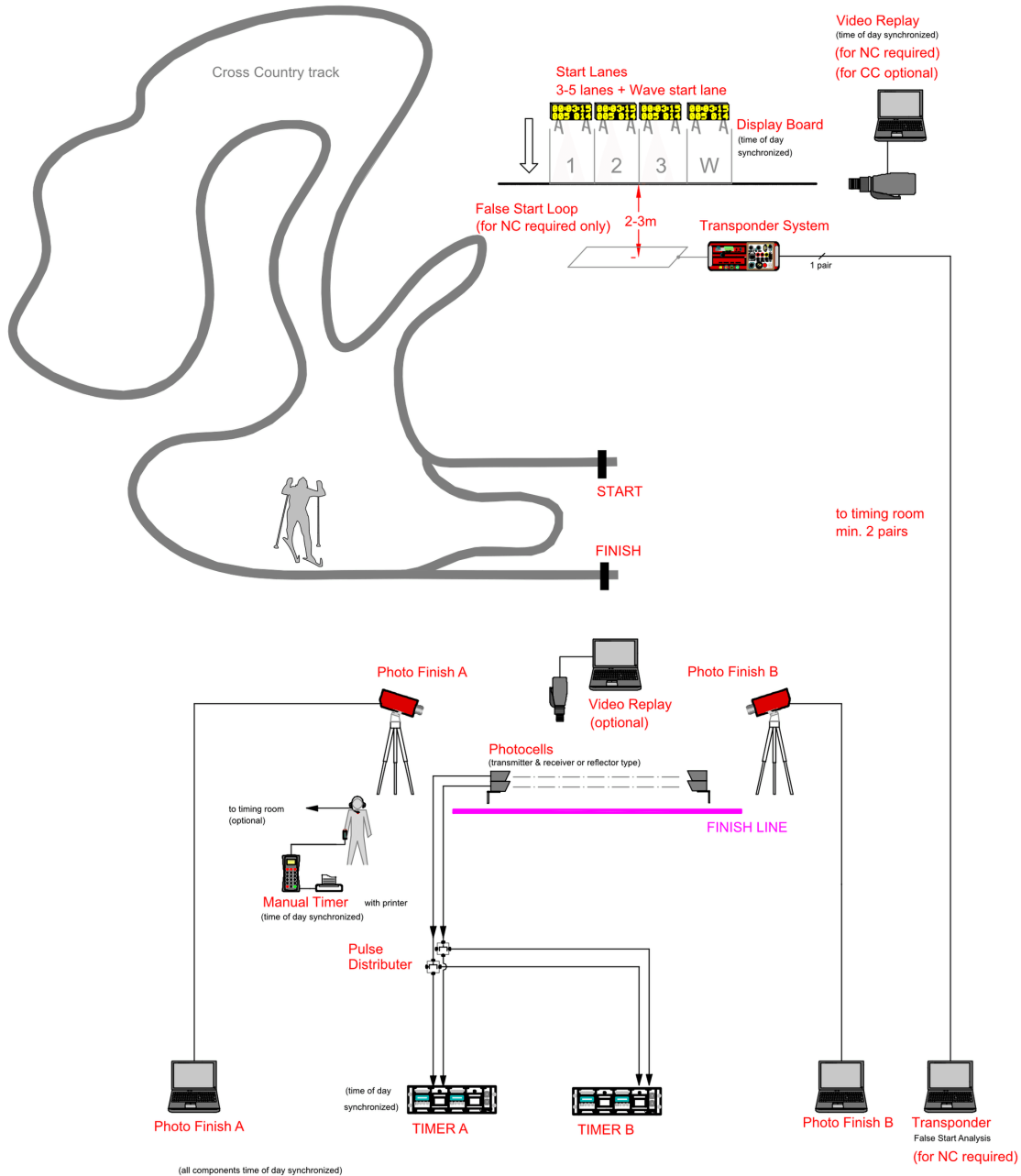

	Drawn by	Swiss Timing / Mis	Cross Country Skiing Timing System Level 0 Pursuit / NC Individual
	Date	30.10.2025	
	Proved by	Swiss Timing	
	Version	V009/PU0	
	File name	tb_0009.ndw	
CC-FIS-Lv0 / PU 0		INTERNATIONAL SKI AND SNOWBOARD FEDERATION (FIS)	

10.5. Level 1 – Interval / Sprint Qualification Start

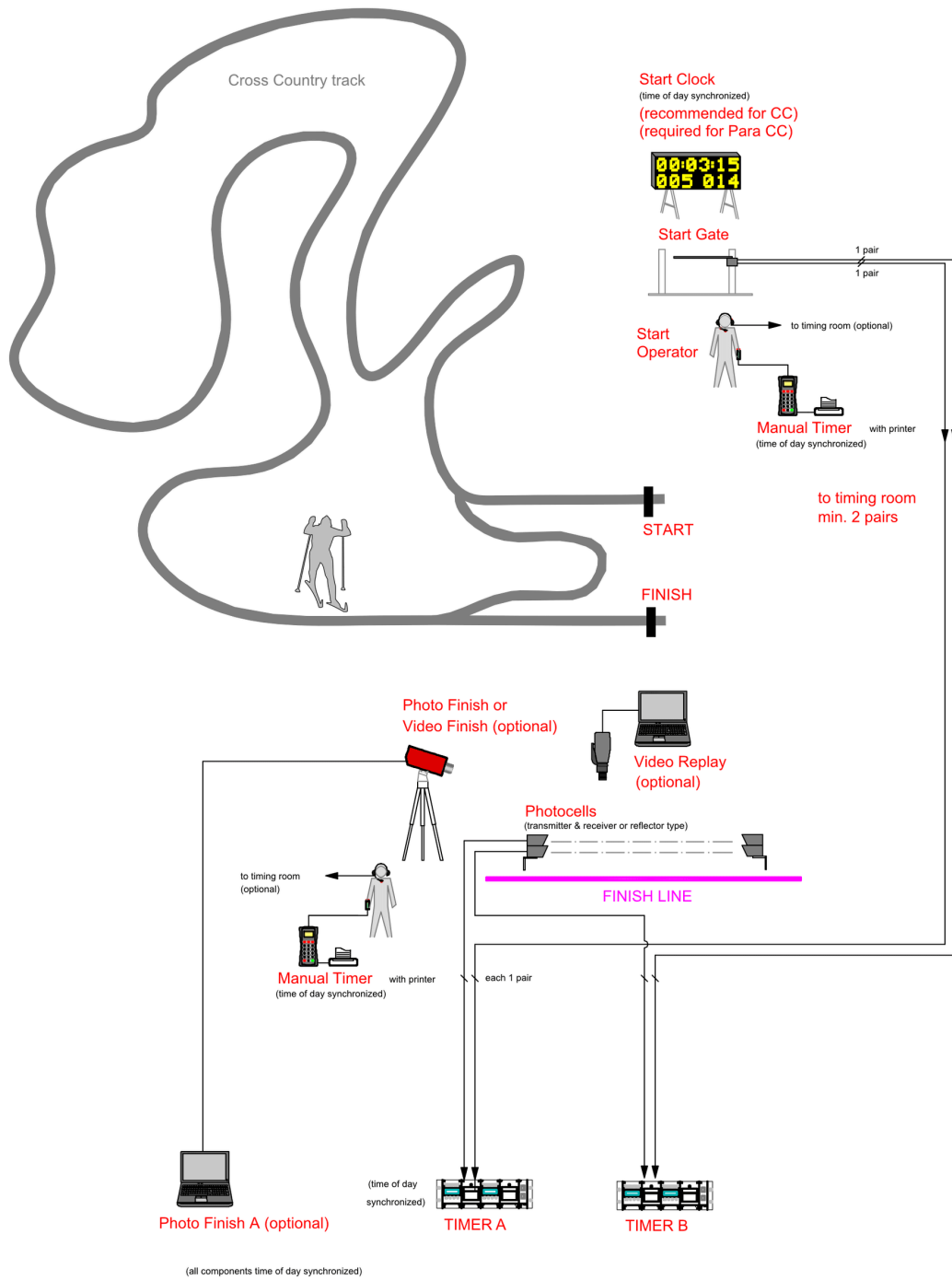

	Drawn by	Swiss Timing / Mis	Cross Country Skiing Timing System Level 1 Interval Start & Sprint Qualification Timer A / B + Photocells A / B + Photo or Video Finish INTERNATIONAL SKI AND SNOWBOARD FEDERATION (FIS)
	Date	19.04.2026	
	Proved by	Swiss Timing	
	Version	V010/IN1	
	File name	tb_00910.ndw	
CC-FIS-Lv1 / IN 1			

10.6. Level 1 – Sprint Final

10.6.1. Timer A + B, Photocells A + B, Photo finish

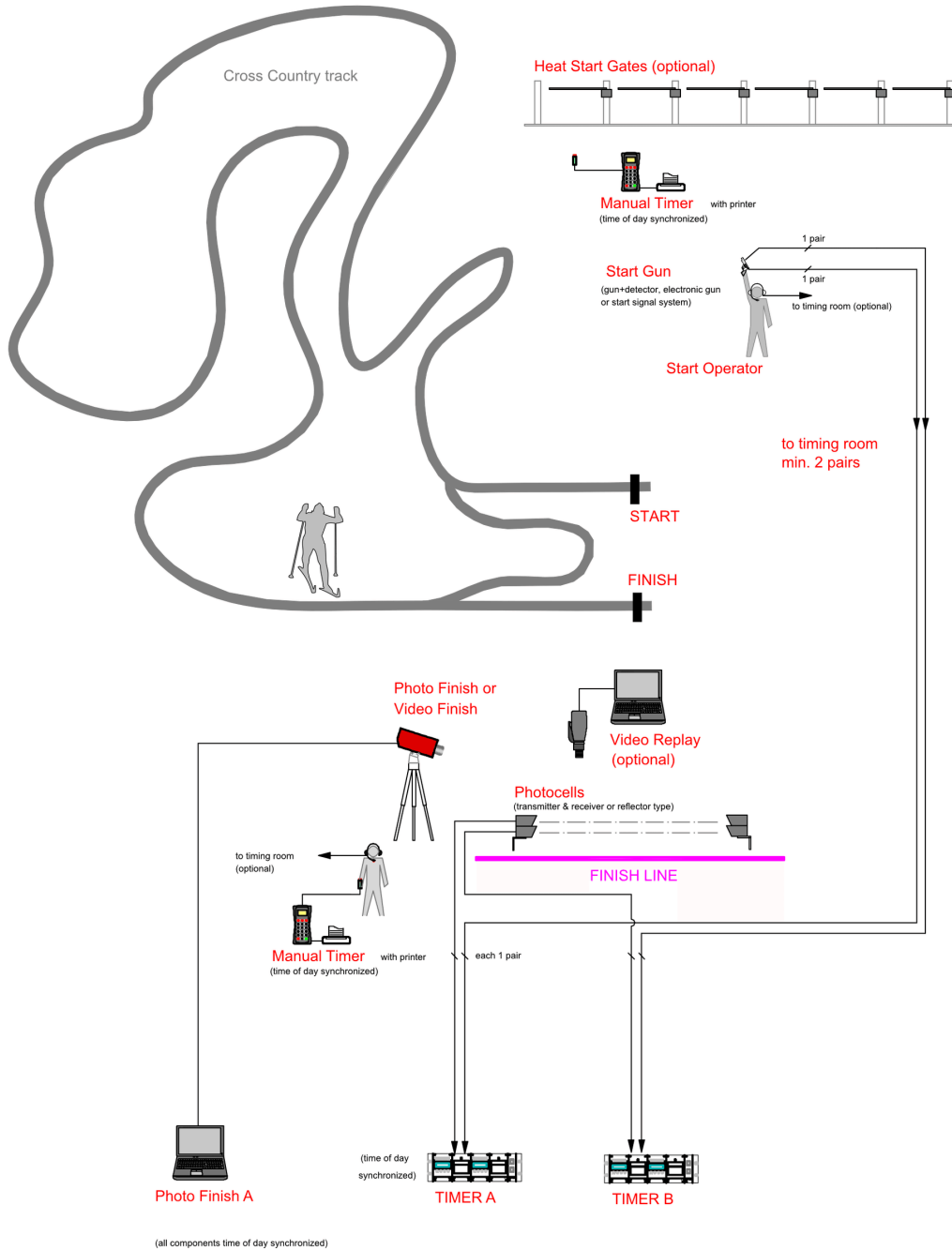

	Drawn by	Swiss Timing / Mis	Cross Country Skiing Timing System Level 1 Sprint Final's Timer A / B + Photocells A / B + Photo or Video Finish INTERNATIONAL SKI AND SNOWBOARD FEDERATION (FIS)
	Date	30.10.2025	
	Proved by	Swiss Timing	
	Version	V009/SF1	
	File name	tb_0009.ndw	
	CC-FIS-Lv1 / SF 1		

10.6.2. Timer A, Photocells A, Photo finish

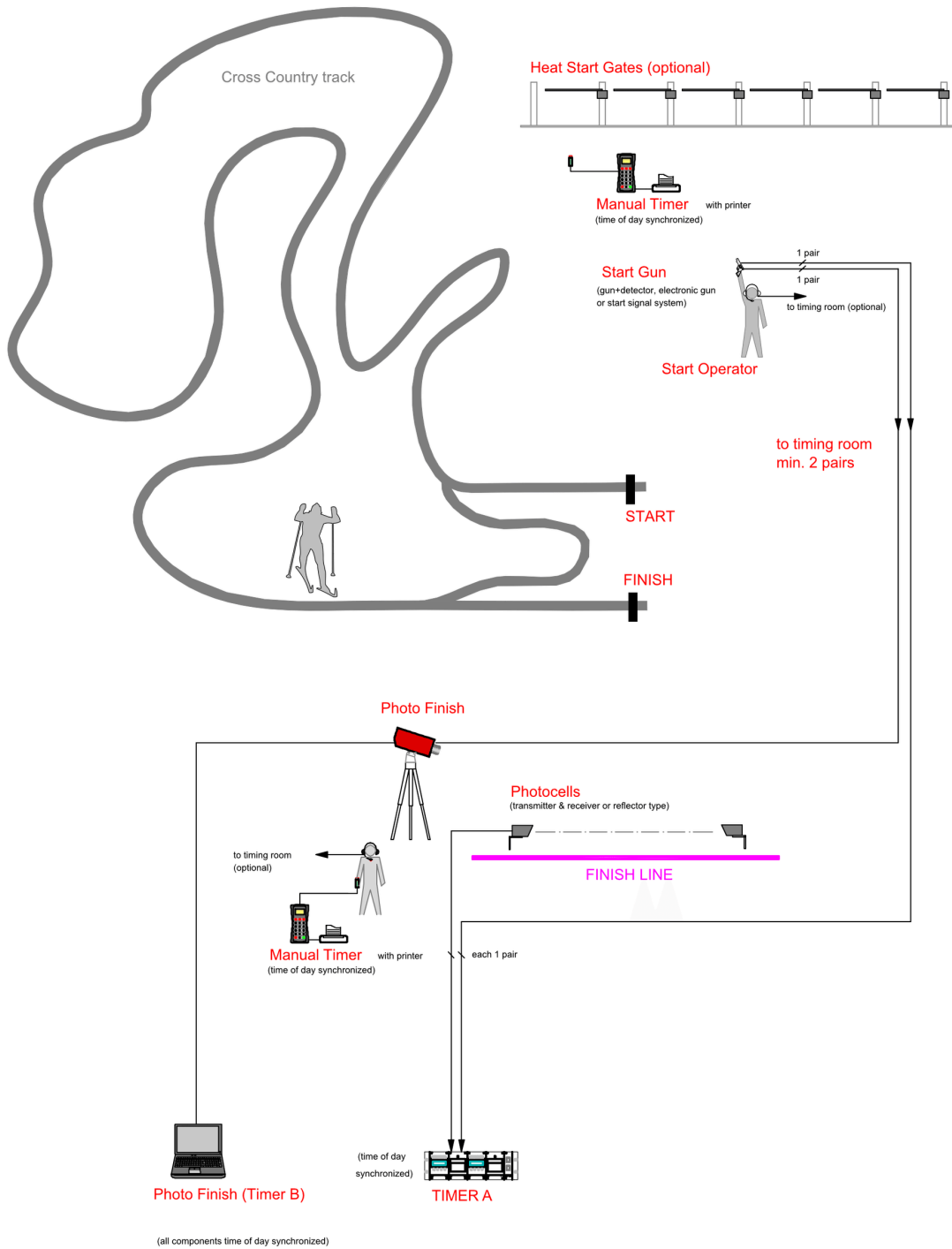

	Drawn by	Swiss Timing / Mis	Cross Country Skiing Timing System Level 1 Sprint Final's Timer A + Photocells A + Photo Finish
	Date	30.10.2025	
	Proved by	Swiss Timing	
	Version	V009/SF2	
	File name	tb_0009.ndw	
	CC-FIS-Lv1 / SF 2		
		INTERNATIONAL SKI AND SNOWBOARD FEDERATION (FIS)	

10.6.3. Photo finish A + B

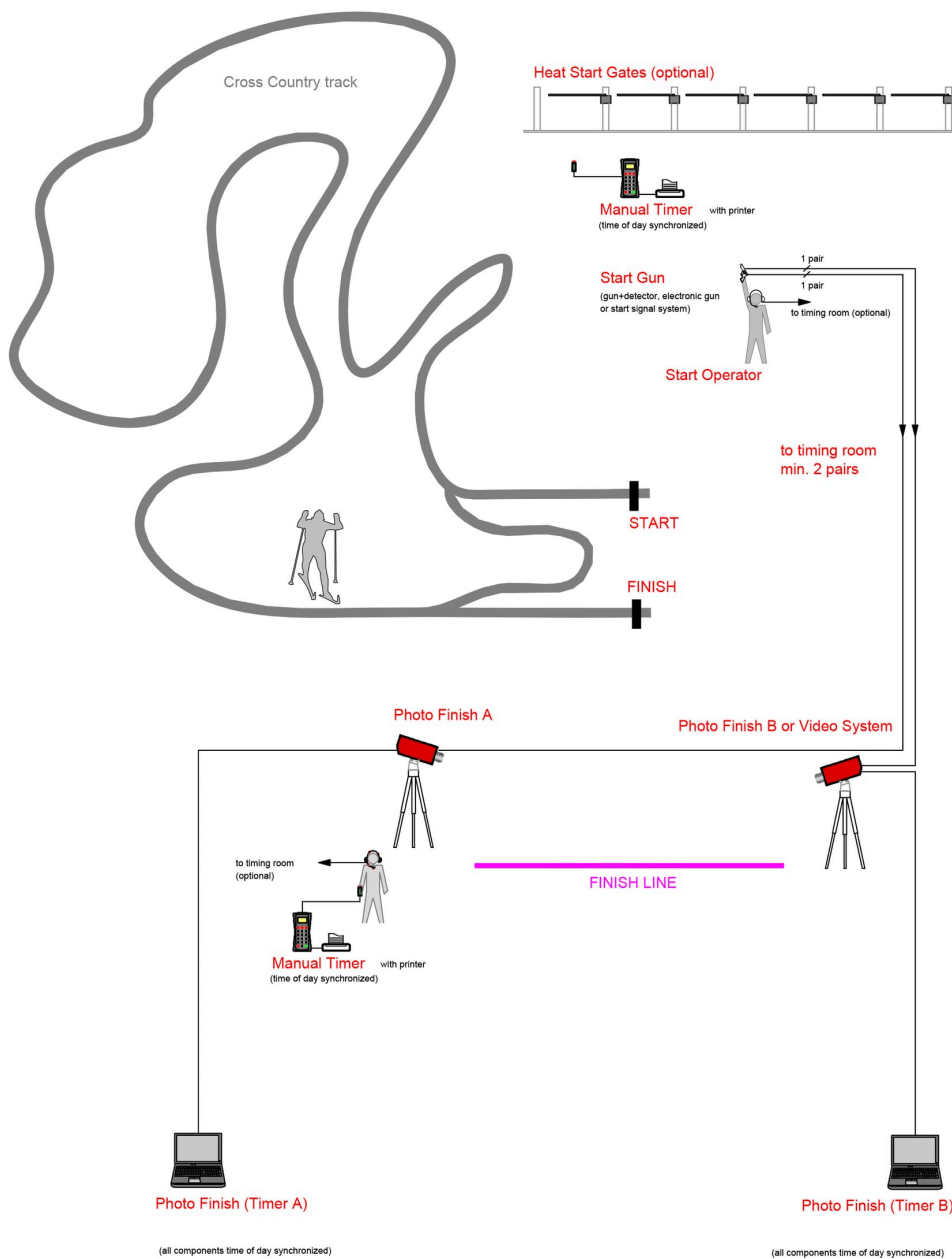

	Drawn by	Swiss Timing / Mis	Cross Country Skiing Timing System Level 1 Sprint Final's Photo Finish A / B
	Date	17.10.2023	
	Proved by	Swiss Timing	
	Version	V007/SF3	
	File name	tb_0008.ndw	
CC-FIS-Lv1 / SF 3		INTERNATIONAL SKI AND SNOWBOARD FEDERATION (FIS)	

10.7. Level 1 – Mass Starts

10.7.1. Timer A + B, Photocells A + B, Photo finish

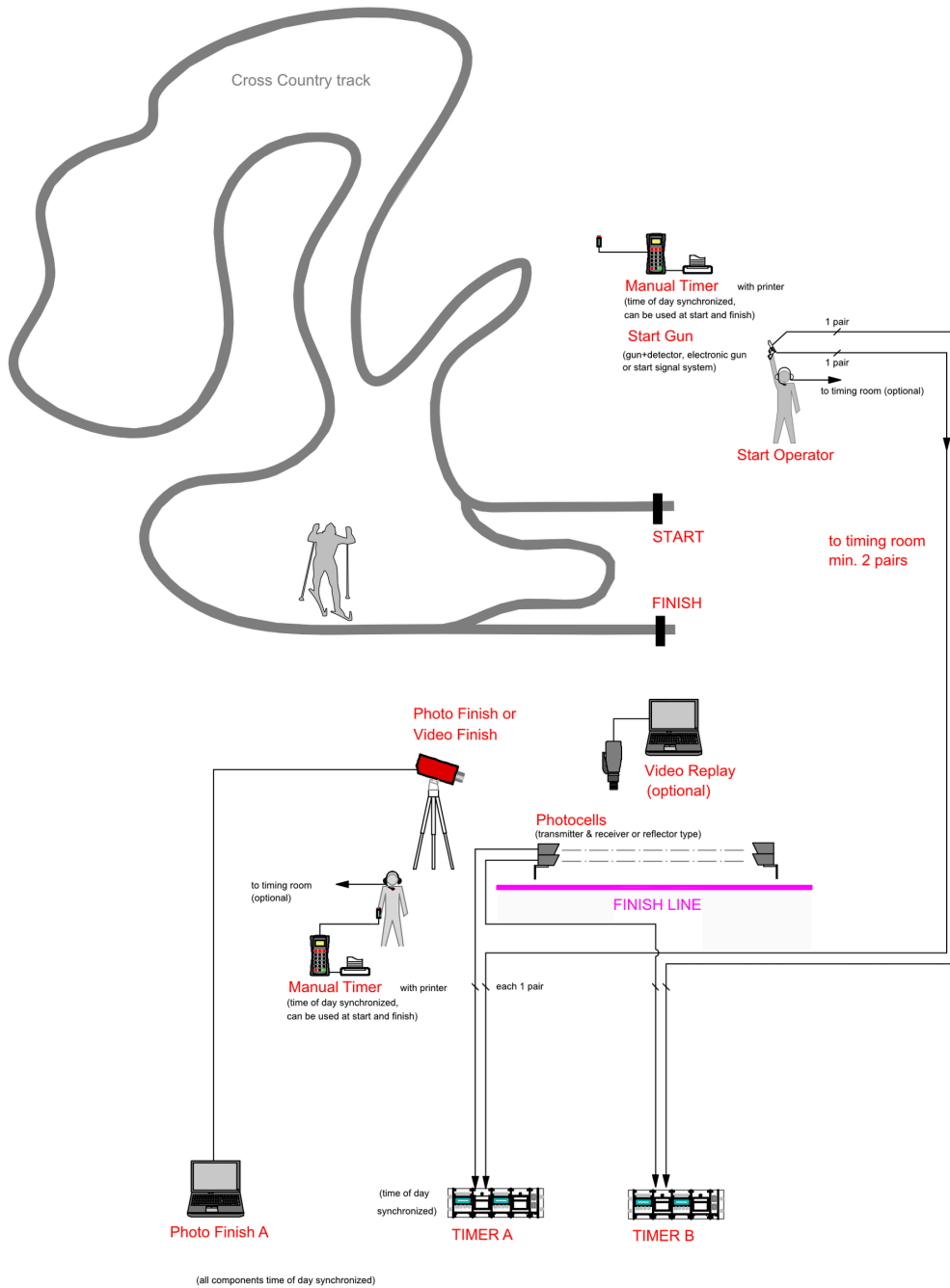

	Drawn by	Swiss Timing / Mis	Cross Country Skiing Timing System Level 1 Mass Start Timer A / B + Photocells A / B + Photo or Video Finish
	Date	30.10.2025	
	Proved by	Swiss Timing	
	Version	V009/MS1	
	File name	tb_0009.ndw	
	CC-FIS-Lv1 / MS 1		
			INTERNATIONAL SKI AND SNOWBOARD FEDERATION (FIS)

10.7.2. Timer A. Photocells A, Photo finish

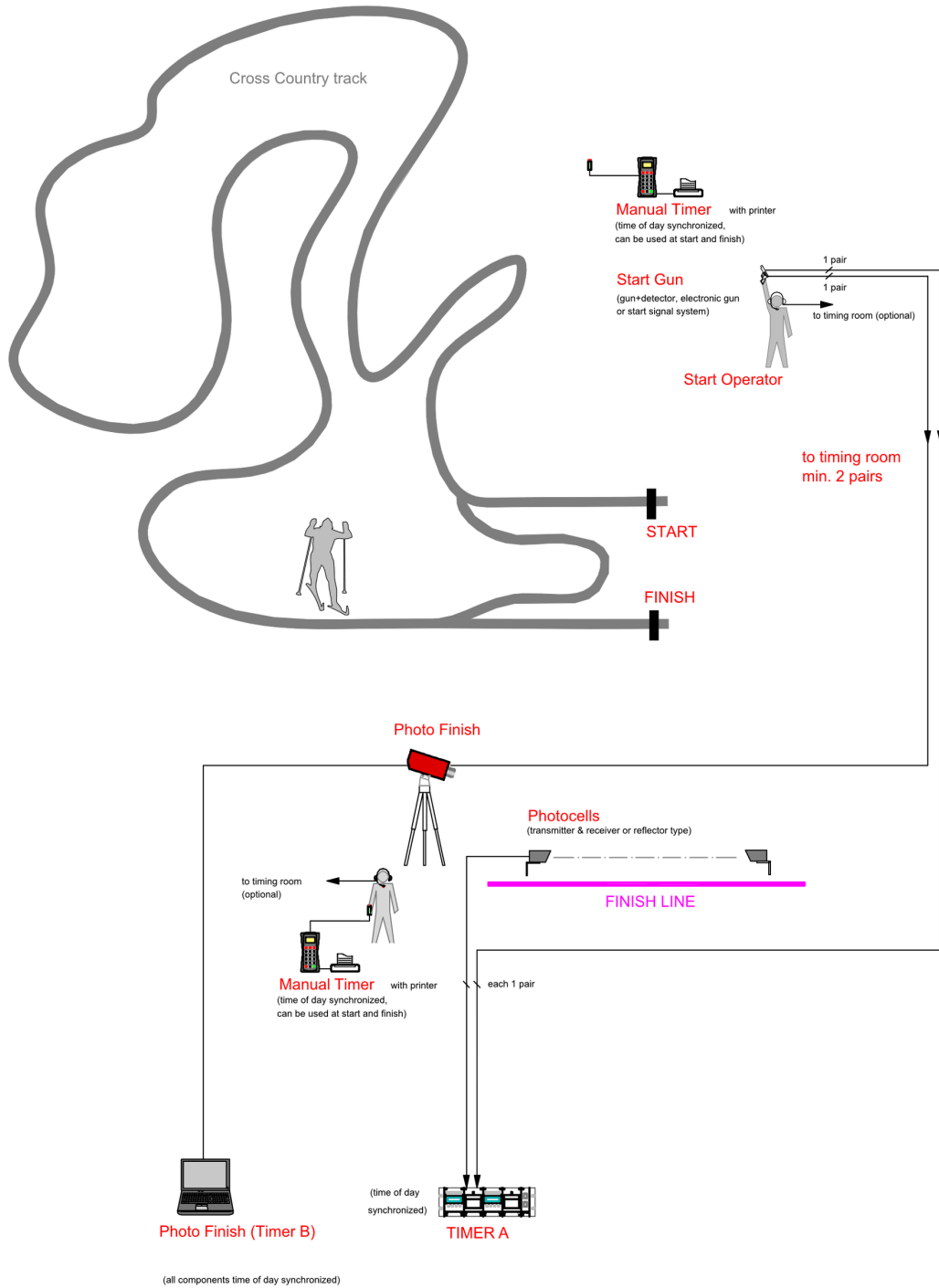

	Drawn by	Swiss Timing / Mis	Cross Country Skiing Timing System Level 1 Mass Start Timer A + Photocells A + Photo Finish
	Date	30.10.2025	
	Proved by	Swiss Timing	
	Version	V009/MS2	
	File name	tb_0009.ndw	
CC-FIS-Lv1 / MS 2		INTERNATIONAL SKI AND SNOWBOARD FEDERATION (FIS)	

10.7.3. Photo finish A + B

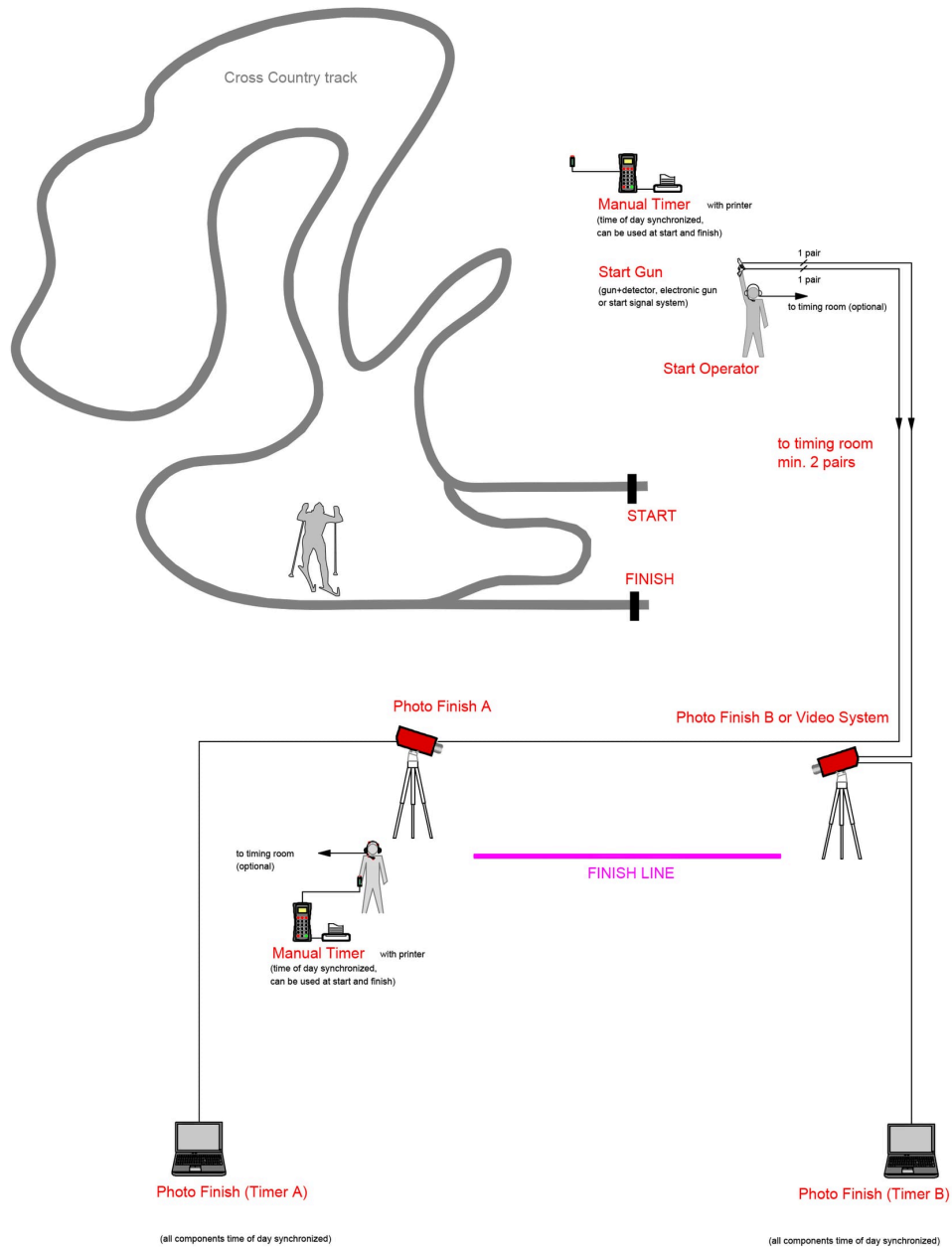

	Drawn by	Swiss Timing / Mis	Cross Country Skiing Timing System Level 1 Mass Start Photo Finish A / B
	Date	17.10.2023	
	Proved by	Swiss Timing	
	Version	V007/MS3	
	File name	tb_0008.ndw	
CC-FIS-Lv1 / MS 3		INTERNATIONAL SKI AND SNOWBOARD FEDERATION (FIS)	

10.8. Level 1 – Cross-Country Pursuit, Nordic Combined Gundersen Start

10.8.1. Timer A + B, Photocells A + B, Photo finish

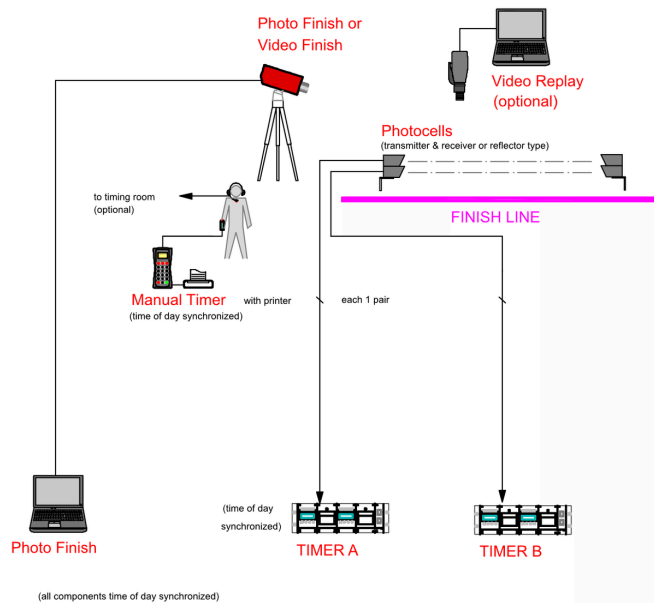
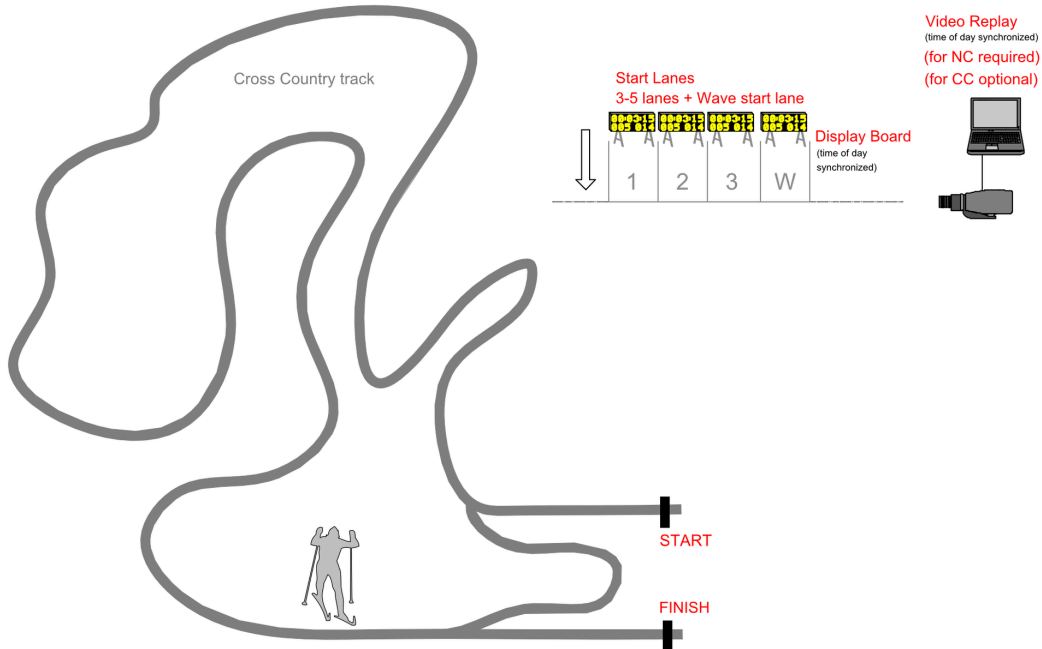

	Drawn by	Swiss Timing / Mis	Cross Country Skiing Timing System Level 1 Pursuit / NC Individual Timer A / B + Photocells A / B + Photo or Video Finish INTERNATIONAL SKI AND SNOWBOARD FEDERATION (FIS)
	Date	30.10.2025	
	Proved by	Swiss Timing	
	Version	V009/PU1	
	File name	tb_0009.ndw	
CC-FIS-Lv1 / PU 1			

10.8.2. Timer A. Photocells A, Photo finish

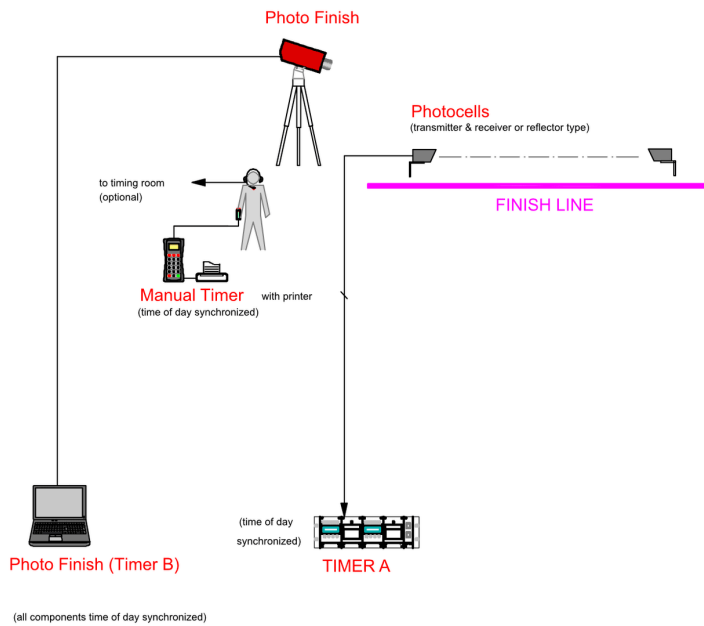
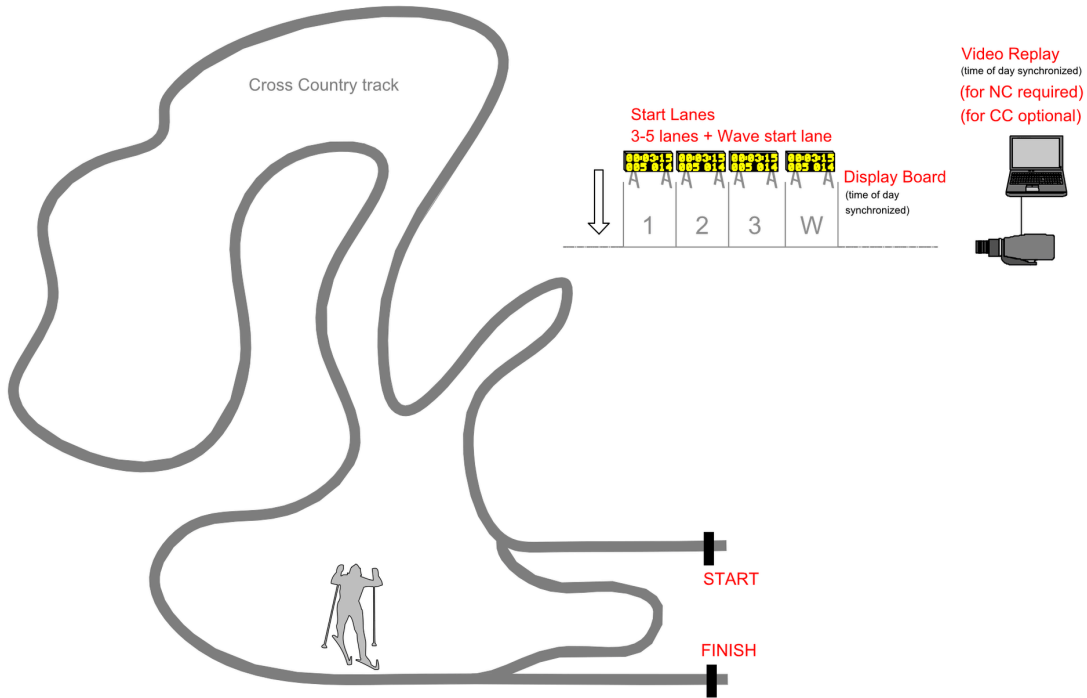

	Drawn by	Swiss Timing / Mis	Cross Country Skiing Timing System Level 1 Pursuit / NC Individual Timer A + Photocells A + Photo Finish
	Date	30.10.2025	
	Proved by	Swiss Timing	
	Version	V009/PU2	
	File name	tb_0009.ndw	
CC-FIS-Lv1 / PU 2		INTERNATIONAL SKI AND SNOWBOARD FEDERATION (FIS)	

10.8.3. Photo finish A + B

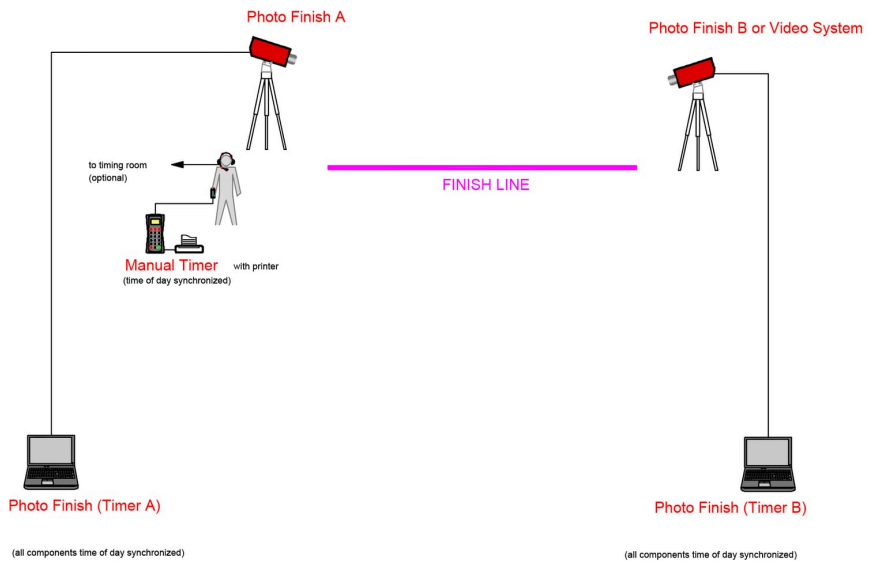
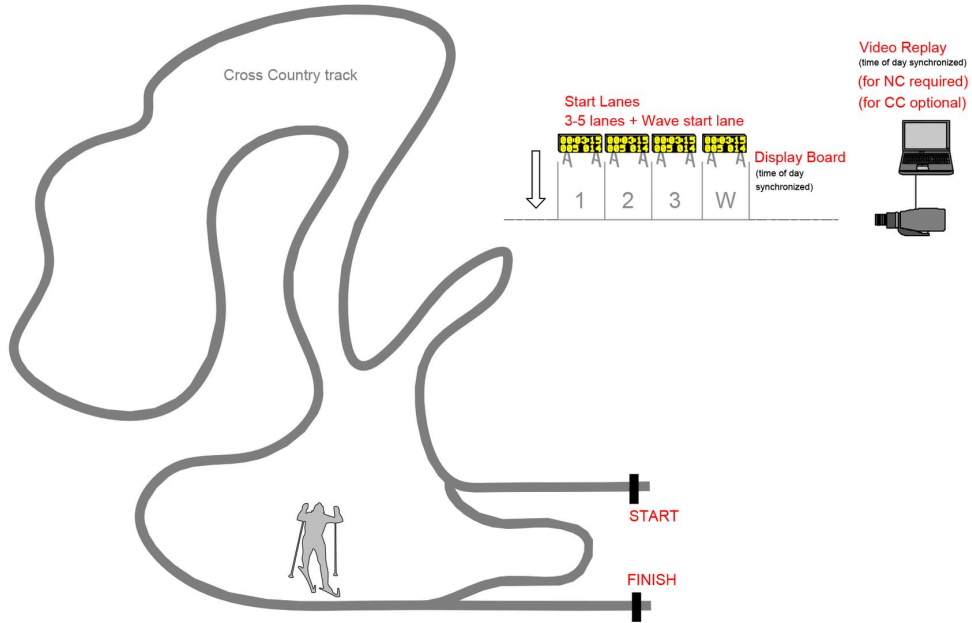

	Drawn by	Swiss Timing / Mis	Cross Country Skiing Timing System Level 1 Pursuit / NC Individual Photo Finish A / B
	Date	17.10.2023	
	Proved by	Swiss Timing	
	Version	V007/PU3	
	File name	tb_0008.ndw	
CC-FIS-Lv1 / PU 3		INTERNATIONAL SKI AND SNOWBOARD FEDERATION (FIS)	

10.9. Level 1 – Interval Start (wireless)

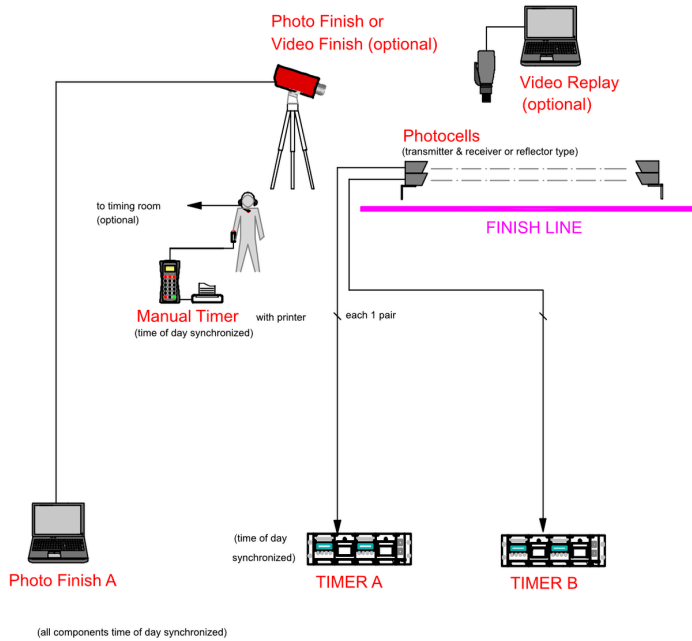
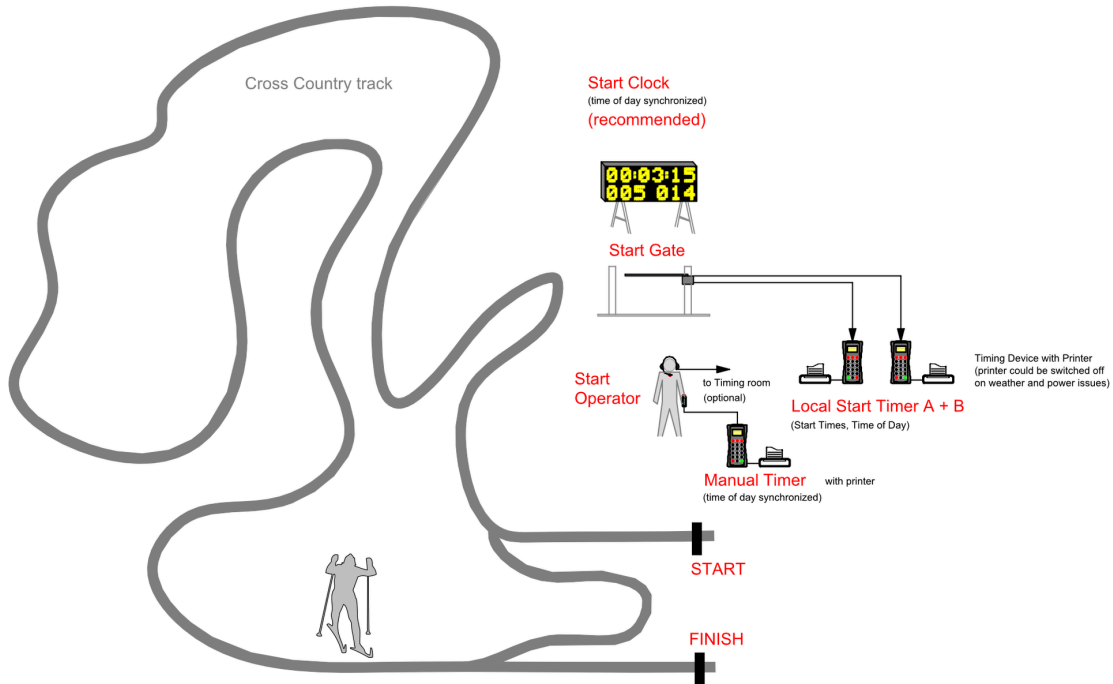

	Drawn by	Swiss Timing / Mis	Cross Country Skiing Timing System Level 1 (no cables) Interval Start & Sprint Qualif. Timer A / B + Photocells A / B + Photo or Video Finish
	Date	30.10.2025	
	Proved by	Swiss Timing	
	Version	V009/IN2	
	File name	tb_0009.ndw	
CC-FIS-Lv1 / IN 2		INTERNATIONAL SKI AND SNOWBOARD FEDERATION (FIS)	

10.10. Level 1 – Mass Start (wireless)

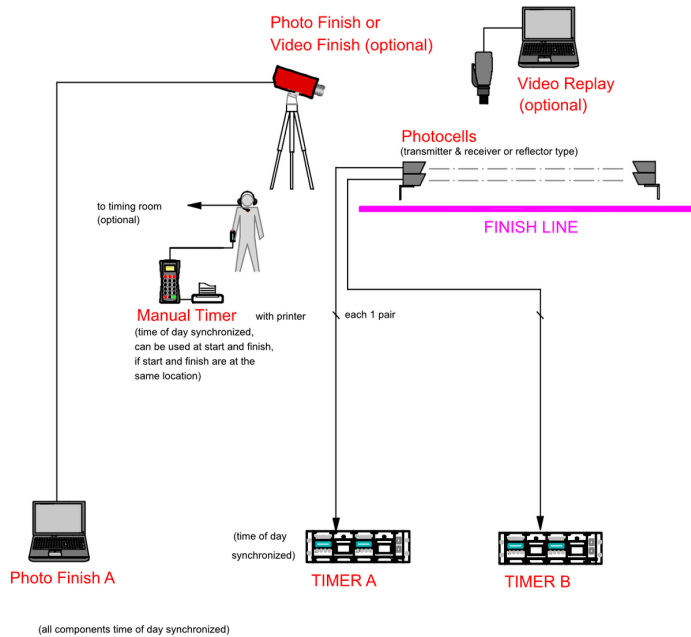
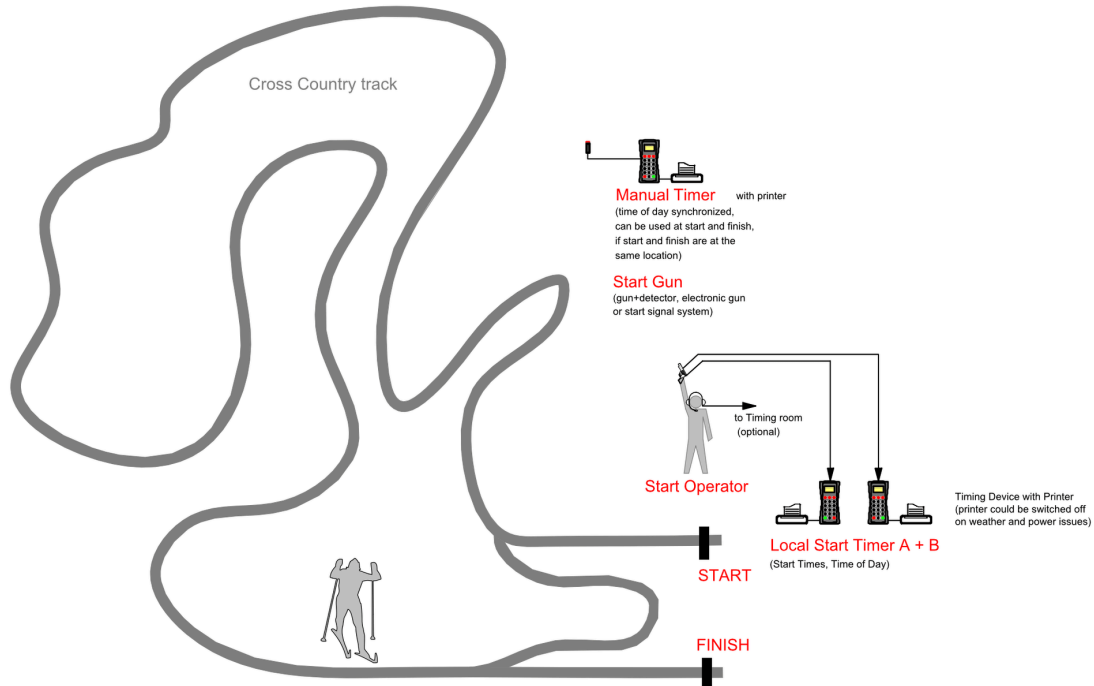

	Drawn by	Swiss Timing / Mis	Cross Country Skiing Timing System Level 1 (no cables) Mass Start Timer A / B + Photocells A / B + Photo or Video Finish INTERNATIONAL SKI AND SNOWBOARD FEDERATION (FIS)
	Date	30.10.2025	
	Proved by	Swiss Timing	
	Version	V009/MS4	
	File name	tb_0009.ndw	
CC-FIS-Lv1 / MS 4			

11. Important ICR rules for Timing in Cross-Country

- 316 Timing
- 316.1 For all competitions listed in the FIS Calendar, electronic timing devices homologated by FIS must be used. Electronic timing will always be supplemented by hand-timing as a backup system and the results cross-checked between the two systems. Competitions using timing equipment other than those on the homologated device list might not be considered for FIS points. All technical details related to the timing equipment specification, installation, timing and procedures are described in the FIS timing booklet.
- 316.1.1 Level 0 requirements described in the FIS timing booklet applies to OWC, WSC, JWSC, U23 and WC. Level 1 requirements applies to all the other FIS events.
- 316.2 With hand timing the time will be taken when the toe of the first boot crosses the finish line. The finish controller determines the correctness of passage across the finish line.
- 316.2.1 In the case of competitors falling as they cross the finish line, the competitors will be assigned their finish time as per articles 316.2, 316.3.5 or 316.3.6 if all the parts of their bodies are moved across the finish line without any outside assistance.
- 316.3 Electronic Timing
- 316.3.1 For all competitions two synchronised electronically isolated timing systems operating in time-of-day must be used. One system will be designated system A (main system), the other system B (back-up system) prior to the beginning of the competition.
- 316.3.1.1 One of the following electronic timing technologies must be used to identify the official finish times:
Electronic timing system based on photocells.
Photo finish system.
- 316.3.2 Transponder
Transponders (active systems) can be used as a supporting system to the official timing system to determine race times and ranking sequences at intermediate timing points, pre-timing points, and finish (unofficial result). The official result must be confirmed accordance with ICR 316.1.1.
- 316.3.3 Start Gate
The start gate must have separate electronically isolated switch contacts for triggering the start inputs of both system A & B.
- 316.3.4 Heat start gates
Electronic and/or mechanical heat start gates can be used if approved by the Jury. Use of start gates is mandatory at level 0 competitions.
- 316.3.5 Photocells
If photocells are used, two photocell systems must be installed at the finish line. One is connected to system A. The other is connected to system B. The measuring point of the light or photo barrier must be at a height of 20-30 cm above the ground surface and the time is taken when a competitor triggers the beam between the photo cells.
- 316.3.6 Photo Finish Camera
The photo finish time is taken when the toe of the first boot meeting the finish line. The photo

finish result is to be provided at first to the Jury. Photo finish at Finish is mandatory for level 0 competition.

316.3.7 Start Clock

For competitions with individual start the use of a start clock that provides at least an acoustic countdown signal on the fixed start interval as prescribed by the Jury should be used as an aid to race management.

316.4 Hand Timing

Manual (hand) timing, completely separate and independent of the electronic timing, must be used for all competitions listed in the FIS Calendar. Stopwatches or hand operated battery powered timers that are installed at both the Start and the Finish and capable of expressing the time of day to at least 1/100th (0.01) precision qualify as proper hand timing devices. They must be synchronised prior to the start of the first run, with the same time-of-day as system A and system B. Printed records, either automatic or hand-written, of recorded hand times must be immediately available at the start and at the finish

316.5 The OC is responsible for keeping a list of the order in which the competitors cross the finish line.

316.6 An electronic timing report for every competition must be transmitted to FIS.

316.7 In any case the authority to validate the results and awarded FIS Points remains vested at the FIS Technical Delegate.

317 Results

317.1 Calculation of Results

317.1.1 For the calculation of results all start and finish time of the day will be recorded in the precision of the timer used. The calculated net time for each competitor is determined by subtracting the recorded start time of the day from the recorded finish time of the day. The final result for each competitor will be determined to 1/10th (0.1) or 1/100th (0.01) precision by truncating the calculated net time.

Examples:

38:24.381 becomes 38:24.3

2:27.576 becomes 2:27.57

317.2 Result time precision

Interval Start	Sprint Qualification	Sprint Heats	Mass Start	Pursuit	Team Sprint	Relay
1/10s (0.1)	1/100s (0.01)	1/100s (0.01)*	1/10s (0.1)	1/10s (0.1)	1/100s (0.01)	1/10s (0.1)

* For Level 0 result times must be available in 1/1000s to determine lucky loser between different heats

317.1.3 The overall standing in a stage competition will be calculated by accumulating:

- the results (actual times) where tenths of seconds are truncated from each stage prior to last stage. The results of the qualification round will be used for sprint competitions.
- The result (actual times) with the tenths of seconds from the last stage.
- Bonus seconds and time penalties from each stage

317.1.4 The ranking of athletes involved in a photo finish will be established according to the order they crossed the vertical plane of the finish line by the toe of the front foot.

12. Important ICR rules for Timing in Nordic Combined (Cross-Country)

501.2.11 The Chief of Timekeeping

is responsible for the direction and coordination of the officials working in the timing area. He supervises manual timers, electronic timers, intermediate timekeepers and calculations officials' work. He coordinates the work of the starter and the finish referee with the chief of stadium. He supervises the data processing services and supports the distribution and collecting of transponders.

The chief of timekeeping and data processing oversees the preparation of the Timing and Data Technical Report (TDTR) and xml file for the electronic transmittal to FIS following the competition. A copy of the report may also be printed (only if the TD has no access to his report) for review prior to the transmission of the xml file. The TDTR Software can be found on the FIS website.

503.1.5 The Duties of the Technical Delegate

503.1.5.1 Before the Competition

- TD has the responsibility to check that the requirements of the FIS Timing Booklet are fulfilled, according to the level of the competition.

...

503.1.5.3 After the competition

Immediately after the competition ends, the TD is responsible for the final Jury meeting, where the conclusion of the competition or decisions of the protests are prepared in writing. The TD must do the report on all aspects of the event. The report shall consist of the designated report form and any additional comments deemed relevant. This report shall include but is not limited to a discussion of organisational preparation, preparation of the hill(s), an evaluation of the competitive event, a final results list and a complete set of minutes from all meetings and Jury decisions. Without TD and timing reports the result will not be valid. The report is available online.

504.2.2 Finish Referee

The finish referee is responsible for keeping a list and a voice recorder (dictaphone) of the order in which the competitors cross the finish line. He gives this list and the tape to the chief of timekeeping.

513.2.6 Timekeeping building

Timekeeping and calculation should be located in a building with a good view of the start and finish.

514.2 Measuring Devices for Cross-Country

For all competitions listed in the FIS Calendar, electronic timing system A + B and electronic devices homologated by FIS must be used. Competitions using timing equipment other than those on the homologated device list might not get valid in Nordic Combined.

Specifications and procedures for timing are more fully described in a separate FIS Timing Booklet.

Electronic timing will always be supported by hand timing as a backup system and the results cross checked between the two systems.

- 514.2.1 Race level classifications of FIS Timing Booklet
Levels requirements described in the timing booklet applies to:
- Level 0 for OWG, WSC, WC and JWSC
- Level 1 to all the other FIS events
- 514.2.2 Electronic timing
One of the following electronic timing technologies must be used to identify the official finish times:
- Electronic timing system based on photocells.
If photocells are used, Wire must be used to connect photocells to the timer. Wireless is not allowed. The measuring point of the light or photo barrier must be at a height of 20-30 cm above the ground surface and the time is taken when a competitor triggers the beam between the photocells
- Photo finish system.
The photo finish time is taken when the toe of the first boot meeting the finish line. The photo finish result is to be provided to the Jury only. Photo finish system is mandatory for level 0 competition.
- 514.2.3 Timing devices
For all competitions two synchronised electronically isolated timing systems operating in time-of-day must be used. One system will be designated system A (main system), the other system B (back-up system) prior to the beginning of the competition. The different equipment set-up with practical example for these systems are described in the FIS Timing Booklet.
Manual (hand) timing, completely separate and independent of the electronic timing, must be used for all competitions listed in the FIS Calendar. Hand timer, with or without printers, showing times to at least 1/100th second should be synchronized to the time of day (with the same time-of-day as system A and system B) and used at the start and at the finish.
- 514.2.4 Timekeeping – Start
The Gundersen start is carried out without an electronic start gate. In order to guarantee an exact start, a large display digital board must be used. It must be synchronised prior to the start, with the same time-of-day as system A and system B. The clock is started by zero time when the first competitor starts. At the same time, the starters must start an additional stop watch for control. The starting procedure must be recorded by a HD video camera which focused to the clearly marked starting line (see marking start line, art. 515.2.7).
As a backup system for OWG, WSC, WC and WJC an additional transponder line has to be placed 1,5 m beyond the starting line. The reference time for the Jury to check the start procedure is 1 second, which means all earlier starts must be checked.
- 514.2.5 Intermediate Time
An intermediate timing point will be established according to the local circumstances and the respective length of the course. In principle it should be 1 – 2 intermediate timing points per round.
- 514.2.6 Finish Timing
Times will be measured in full tenths of a second. Times to one hundredth of a second will not be used.
When using hand timing, the time is taken when the competitor's first foot crosses the finish line.
In case of electronic timing, the time is taken when the contact is broken. The measuring point of the light or photo barrier must be at a height of 20-30 cm above the ground surface.

Additionally, the finish is to be recorded by video cameras. The first camera must be positioned on one the side of the finish line providing a picture of the finish and an additional camera positioned to identify the starting bibs.

514.2.7 Photo-Finish camera

At OWG, WSC, WC and WJC special Photo-Finish cameras (Line-CCD) must be employed to record the correct order of finish. To attain a correct and swift result evaluation, it is imperative that every competitor wears an additional starting bib on the outside of his thigh where the camera position is. The height of the starting bib digits should not be less than 8 cm.

The Line-CCD camera must be able to register finish line crossing with a 1/1000 s precision. The CCD camera must be synchronised with the time of day mode used as timing device at least 1 hour before competition starts. The display of the time behind the winner or display of the running time is sufficient.

In the case of Photo-Finish decisions, the image of the Line-CCD camera must be presented on the system monitor to the Jury, additionally a colour print-out with time scale is required.

514.2.8 **Photo Finish**

The use of technical measurements (Video camera, Line-CCD camera) shall be used in the following situations for the determination of the actual final ranking:

- if the finishing times are identical
- a difference in the finish ranking list made by the finish referees
- the difference between two or more athletes crossing the finish cannot be clearly witnessed.

514.3 **Transponder Timekeeping**

Transponders (active systems) can be used as a supporting system to the official timing system to determine race times and ranking sequences at intermediate timing points, pre-timing points, and finish (unofficial result).

The official result must be confirmed by using electronic timing systems in accordance with ICR 514.2.2.

For Gundersen competitions the order at the finish is the ranking criteria for the official result. The finish order must be confirmed in any case with the photo finish system. In case of usage of transponders, the determined finish times can be used for the official result when the finish order is confirmed by photo finish system.

515.2.7 **Start Area**

The start must be prepared according to the terrain, with the first 100–200 m prepared to a width at 6–9 m.

In order to guarantee an exact start, a large digital clock and a board with the starting numbers and starting times for each starting lane must be used. The clock is started by zero time when the first competitor starts. At the same time, the starters have to start an additional stop watch for control.

The start line must be clearly marked by a coloured line. The use of coloured planks with a width of max. 10 cm placed lower than the prepared snow is recommended. This start line must be placed at right angles to the skiing direction.

13. Important ICR rules for Timing in Para Cross-Country

12316 Timing

- 12316.1 For all competitions listed in the FIS Calendar, electronic timing devices homologated by FIS must be used. Electronic timing will always be supplemented by hand-timing as a backup system and the results cross-checked between the two systems. Competitions using timing equipment other than those on the homologated device list might not be considered for FIS points. All technical details related to the timing equipment specification, installation, timing and procedures are described in the FIS timing booklet.
- 12316.1.1 Level 0 requirements described in the FIS timing booklet applies to PWG, WSC and WC. Level 1 requirements apply to all the other FIS Para Cross-Country events.
- 12316.2 With hand timing the time will be taken when for the Standing and Vision Impaired categories the toe of the first boot crosses the finish line; and for the Sitting category the front binding. The finish controller determines the correctness of passage across the finish line.
- 12316.2.1 *In the case of competitors falling as they cross the finish line, the competitors will be assigned their finish time as per articles 12316.2, 12316.3.5 or 12316.3.6 if all the parts of their bodies are moved across the finish line without any outside assistance.*

12316.3 Electronic Timing

- 12316.3.1 For all competitions two synchronised electronically isolated timing systems operating in time-of-day must be used. One system will be designated system A (main system), the other system B (back-up system) prior to the beginning of the competition.
- 12316.3.1.1 One of the following electronic timing technologies can be used to identify the official finish times:
Electronic timing system based on photo cells.
Photo finish system.
- 12316.3.1.2 For the VI category the clock will be started and stopped as the competitor (not the guide) crosses the line. The time of the guide must not be recorded.
- 12316.3.2 Transponder
Transponders (active systems) can be used as a supporting system to the official timing system to determine race times and ranking sequences at intermediate timing points, pre-timing points, and finish (unofficial result). The official result must be confirmed according to ICR 12316.3.1.1.
For the Sitting category: The transponder must not be fixed ahead of the front binding.
- 12316.3.3 Start Gate
The start gate must have separate electronically isolated switch contacts for triggering the start inputs of both system A & B.
- 12316.3.5 Photocells
If photocells are used, two photocell systems must be installed at the finish line. One is connected to system A. The other is connected to system B. The measuring point of the light or photo barrier must be at a height of 20 - 30 cm above the ground surface and the time is taken when a competitor triggers the beam between the photo cells.

12316.3.6 Photo Finish Camera

The photo finish time is taken when for the Standing and Vision Impaired categories the toe of the first boot meeting the finish line; and for the Sitting category the front binding. The photo finish result is to be provided at first to the Jury. Photo finish at Finish is mandatory for level 0 competition.

12316.3.7 Start Clock

For competitions with interval start the use of a start clock that provides at least an acoustic countdown signal on the fixed start interval as prescribed by the Jury should be used as an aid to race management.

12316.4 Hand Timing

Manual (hand) timing, completely separate and independent of the electronic timing, must be used for all competitions listed in the FIS Calendar. Stopwatches or hand operated battery powered timers that are installed at both the Start and the Finish and capable of expressing the time of day to at least 1/100th (0.01) precision qualify as proper hand timing devices. They must be synchronized prior to the start of the first run, with the same time-of-day as system A and system B. Printed records, either automatic or hand-written, of recorded hand times must be immediately available at the start and at the finish.

12316.5 The OC is responsible for keeping a list of the order in which the competitors cross the finish line.

12316.6 An electronic timing report for every competition must be transmitted to FIS.

12316.7 In any case the authority to validate the results and awarded FIS Points remains vested at the FIS Technical Delegate.

12316.8 Calculation of Start Times

12316.8.1 Calculation of Start times based on the qualification or previous competition

12316.8.2 Calculation of start times in Para Mass Start Competition

14. Homologation of Timing Equipment

The homologation of timing equipment is always valid for 5 years. If there are no rule changes to homologation of the timing equipment will be extended every year. In case of changes the homologation will expire within 5 years.

Manufacturers wishing to have their timing devices, start gate, photocells or photo finish system homologated for use in FIS races must send a request to the Timing Working Group through the FIS office which will instruct the manufacturer to provide all technical information indicated above. Software for photo finish systems is not part of the homologation. The costs of homologation must be paid by the manufacturer.

If a manufacturer homologates prototypes the FIS will not consider it for homologation. Only final versions of a device (as it is sold in public) will be homologated by the FIS.

Attention:

All temperatures for the specification of timing equipment are given with a tolerance of $\pm 1^{\circ}\text{C}$.

14.1. List of Homologated Timing Equipment

The List of homologated timing equipment is not included in the timing booklet. Please check this list on FIS webpage in the Timing & Data section.

<https://www.fis-ski.com/inside-fis/general-fis-documents/timing-data>

15. Conclusion

We hereby wish to thank all members of the "FIS Timing Working Group" who have always used every endeavour to realize this "FIS GUIDE" for their Technical Delegates and event organisers. Our progress since 1996 reflects the balance between accepting new technologies and ensuring the correct evaluation of human performance through fundamental timekeeping concepts.

We wish to acknowledge the major contributions of participating manufacturers, FIS professionals and volunteers from our member National Associations and race organisers who give so much of their time and expertise without which it would be impossible to generate such a document or perspective.

The FIS is pleased to support such a unique group in the world of timekeeping regulation and notices the absence of similar structures in many other high-performance sports that rely so heavily on timing technology for fair and impartial judgement.

We are fully aware that there are still some imperfections in these rules and descriptions and would welcome any constructive proposal as the works proceeds. This document will be continually revised to improve the knowledge of the FIS community for the benefit of all competitions.

Please contact us with your suggestions and comments:

Member	E-mail
Daniel Defago (FIS – Chairman)	defago@fis-ski.com
Ulf Seehase (FIS)	seehase@fis-ski.com
Uldis Brize (FIS)	brize@fis-ski.com
Raphaël Blanchard (SUI)	Raphael.Blanchard@swisstiming.com
Ted Savage (CAN)	tsavage@precisiontiming.com
Albert Vetter (AUT)	albert@alge-timing.com
Federico Gori (ITA)	fgori@microgate.it
Tommy Jauhojärvi (FIN)	tommy@emit.no

16. Document Control

Sources drawings

ALGE-TIMING GmbH, Austria

Swiss Timing, ST Sportservice GmbH, Germany

Seraina Mischol, Caprez Ingenieure AG, Switzerland

Version 1 (November 2018)

Section	Description
Global	Initial version

Version 2 (October 2019)

Section	Description
Global	Grammar, wording corrections, sync texts with timing booklet of other disciplines updates drawings add CC ICR 325.2.1 number of start lanes Sprint Finals update rule changes removed explanation for Timing Report software, to be replaced by software user manual

Version 3 (October 2020)

Section	Description
Global	Add information about the supposed mandatory usage of homologated timing devices Add link for homologated timing equipment Change drawing for wireless setup photo finish optional Add rule 315.3.3 for CC Add text for link about Timing without cable Timer: some precision in the text Start Gate: precision of impulse angle between A and B output Update TWG member list CC National Championships moved to level 1

Version 4 (October 2021)

Section	Description
Global	Update CC rule section Update manual hand timing text Update synchronisation text Add transponder system to synchronisation Update drawings wireless setups Minor text adjustments

Version 5 (October 2022)

Section	Description
Restriction of the document	Update season to 2023/24 when Timing booklet becomes mandatory
General	Add category Masters in CC
Criteria for FIS Approved Timing Devices in Cross-Country/Nordic Combined	Update text → Timers - > Impulse triggering Add text → Timers → Memory Remove the validity text
Timing without Cable Connection Between Start and Finish	Update text
Technical specifications for the start clock	Update text Timer Precision Removed text Interface Update text Power Supply
Homologation of Timing Equipment	Update text
Technical specifications for the photo finish camera	Update text Image Production
Start clock	Removed text about homologation

Version 6 (November 2022)

Section	Description
Timing without cable connection between start and finish	Corrected text

Version 7 (October 2023)

Section	Description
Global	Using interval start instead of individual in Cross-Country Updating levels by using only level 0 and 1 Using Cross-Country Pursuit and Nordic Combined Gundersen start to distinguish the disciplines and respective events
Restriction of the document	Updated text for usage of homologated timing devices in CC and NK
General	Updated text regarding updated ICR CC
Electronic timing	Update text
Start & Finish / Start gate	Update text, removing numbers for wires
Start & Finish / Photocell	Split text for photocells including photo finish to photocells and photo finish
Timing overview by event	Update result precision for sprint finals in level 0 Add exception for cable connection for level 0 (tbd)
Hand Timing	Add new article since hand timing procedure is not part of ICR anymore
Timing Report	Removed download from FTP Updated text
Criteria for FIS Approved Timing Devices in Cross-Country/Nordic Combined	Update text
Timers → Truncation	Update text examples
Timers with external synchronisation	Update to permanent external synchronisation
Photocell installation	Update measuring point according ICR
Cross-Country Handicap start Nordic Combined Gundersen start	Update to display board
Timing without cable connection	Add exception for level 0
Setup examples	Update all drawings from level 1-4 to level 1 Add text for mass start drawings, that manual timer can be the same at start and finish Update in all drawings the FIS name
ICR Cross-Country	Removed all existing rules Added only new timing and result rules
Homologation	Removed last sentence

Version 8 (October 2024)

Section	Description
Technical specifications for the start clock	Definition of the minimum sound output level.
Conclusion	Update Timing Working Group members list
Procedures	Moved Synchronization, Competition in progress, Missed Times and Timing report from chapter Electronic Timing/Timing devices to new chapter Procedures
Electronic Timing/Timing devices	Removed External synchronisation
Level 1 – Interval Start (wireless)	Updated Photo Finish/Video Finish camera as optional
List of Homologated Timing Equipment	Updated URL
Important ICR rules for Timing in Cross-Country	Updated rule texts for art. 316.2 and 316.2.1
Important ICR rules for Timing in Nordic Combined (Cross-Country)	Updated rule texts for art. 503.1.5.3, 514.X, 515.2.7 Removed art. 542, 543
Restriction of the document	Removed article

Version 9 (October 2025)

Section	Description
Booklet	Corrected British spelling and grammar
References to race level classifications	Updates categories
Technical specifications for the photocell	Added reflector size specification
Appendix	Added drawings for synchronisation
Setup example drawings	Minor corrections of spellings
Cross-Country ICR/ Nordic Combined ICR	Updates of editorial changes

Version 10 (June 2026)

Section	Description
Booklet	Incorporated Para Cross-Country corrected typos and quirks Converted the booklet to Markdown as the document base editorial adjustments

Version 11 (June 2026)

Section	Description
Criteria for FIS Approved Timing Devices in Cross-Country/Nordic Combined/Para Cross-Country	Timers: updated Power Supply requirements Timers: updated Operation Temperature to -10° to +60°C Photo finish camera: updated Operation Temperature from +40°C to +60°C

17. Appendix

17.1. Synchronisation procedures

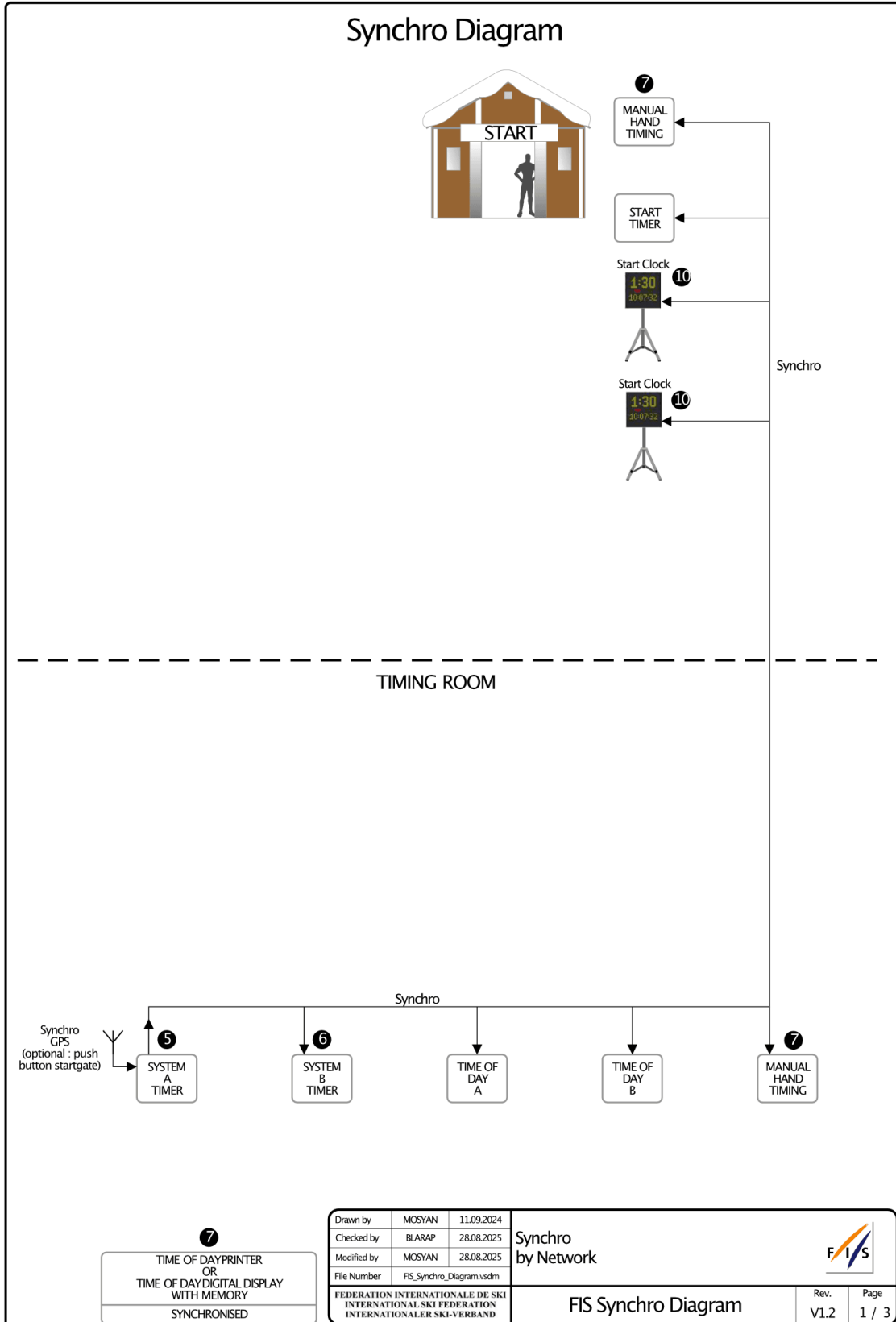

Synchro Diagram

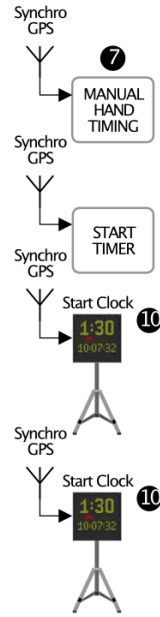

TIMING ROOM

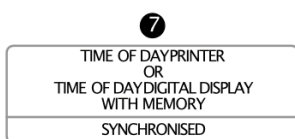
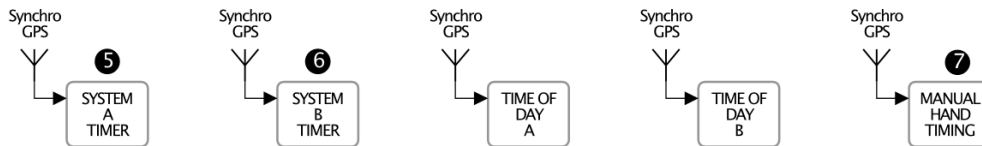

Drawn by	MOSYAN	11.09.2024	Synchro by GPS	
Checked by	BLARAP	28.08.2025		
Modified by	MOSYAN	28.08.2025		
File Number	FIS_Synchro_Diagram.vsdm			
FEDERATION INTERNATIONALE DE SKI INTERNATIONAL SKI FEDERATION INTERNATIONALER SKI-VERBAND			FIS Synchro Diagram	Rev. V1.2 Page 2 / 3

