



FIS PARA ALPINE SKIING
**WORLD CHAMPIONSHIPS
AND WORLD CUP MANUAL**



ABOUT THIS MANUAL

ABOUT THIS MANUAL

This is a training resource manual. It supports the development of a FIS Para Alpine Skiing World Cup (WC) / World Championships (WSC) competition – from event delivery to event production – for sustainable development in general and specific areas.

It is designed for use by organisers with some background experience and understanding of event management so as to assist them to become proficient in running a WC /WSC event.

The manual offers concepts, tools, and examples for use by organisers. It is intended that the concepts and tools be adapted and applied to country & event specific needs and priorities.

After reading this manual, organisers will be able to:

- Understand the WC /WSC and the Organising Committee (OC) structure
- Key processes that contribute to effective and successful communications
- Prepare and maintain the field of play (FOP) in accordance with recommended best practices, FIS Para Alpine International Competition Rules (ICR) and adhere to appropriate safety procedures

GLOSSARY



FoP	Field of Play		World Championships
FIS	International Ski and Snowboard Federation		
HB	Host Broadcaster		
ICR	International Competition Rules		
IPC	International Paralympic Committee		
ITO	International Technical Official		
LAN	Local Area Network		
LOC	Local Organising Committee		
NADA	National Anti-Doping Agency		
NSA	National Skiing Association		
OC	Organising Committee		
PA	Public Announcement		
PoC	Point of Contact		
RD	Race Director		
TCM	Team Captain Meeting		
TD	Technical Delegates		
TV	Television		
VC	Victory Ceremony		
VIP	Very Important Person		
WADA	World Anti-Doping Agency		
WC	World Cup		
WiFi	Wireless radio technology		
WLAN	Wireless Local Area Network		

TABLE OF CONTENTS

SECTION 1: General Info	06
contains information that can be used to help establish a broader events strategy to enhance the overall experience	
SECTION 2: Marketing and Communications	25
contains material to help develop an effective and efficient flow of information to all stakeholders	
SECTION 3: Field of Play	38
provides information necessary to develop and manage all operations related to the track	
SECTION 4: Finish Area	49
contains the proper procedures to organise the mixed zone and the layout of the surrounding area	
SECTION 5: Athlete Services	56
consists of insight on how to properly accommodate athletes and their teams before and during the WC	
SECTION 6: The Toolbox	61
provides information to be used as a supplementary resource. It includes a comprehensive glossary, checklists, and templates	



Section 1: GENERAL INFO

ORGANISATIONAL HIERARCHY

The organisational structure of a WC must be comprised of different people performing specific duties from both the OC and FIS. The OC and FIS organisational chart as described below and throughout the manual provides the basic framework of whom is responsible for performing the various operational roles but does not represent an exhaustive list of staff needed.



ORGANISATIONAL STRUCTURE

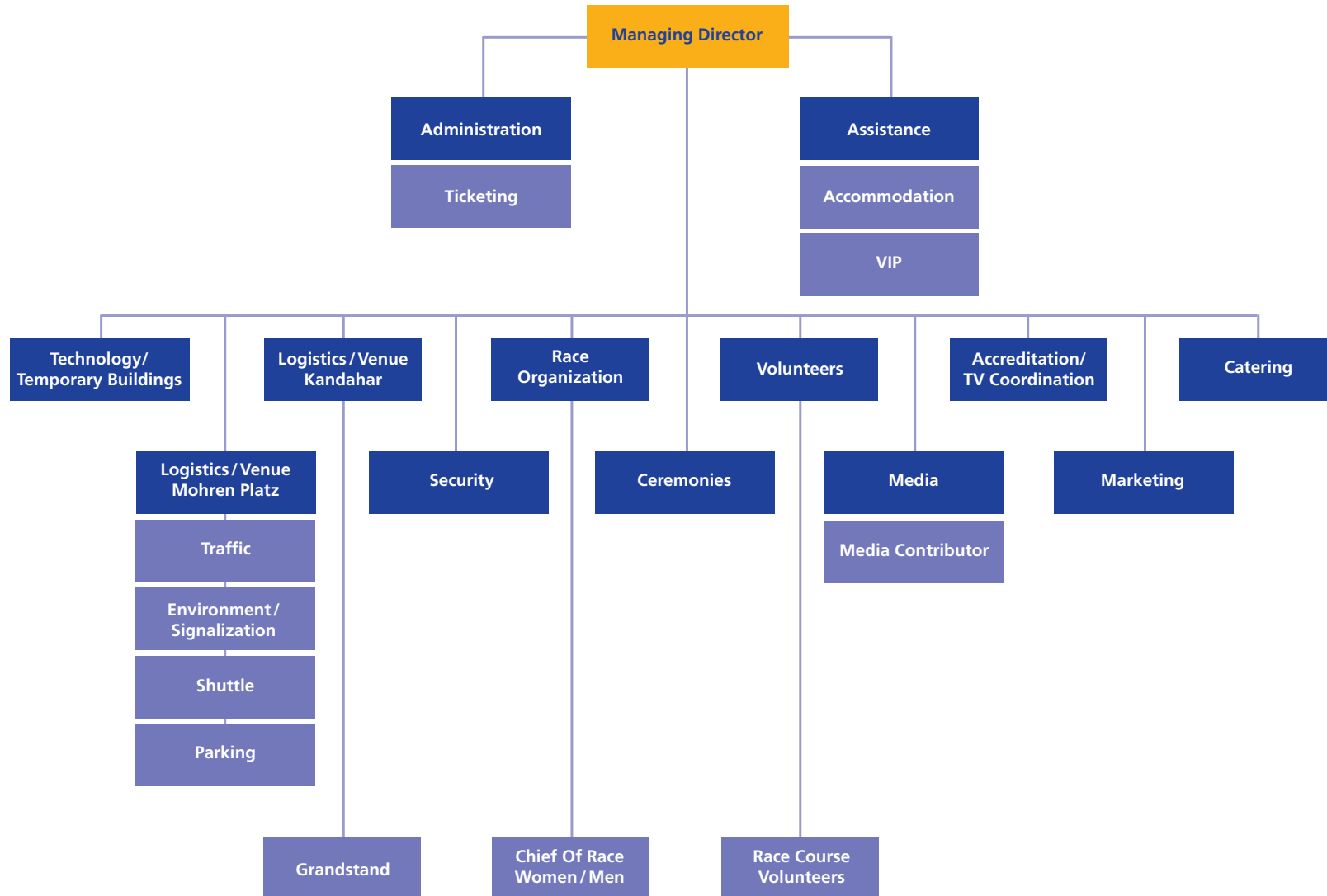

GENERAL LAYOUT WSC WC

OBJECTIVE: DEVELOP VENUE LAYOUT PLAN

The details of the venue lay-out will depend on the specific characteristics of each location but certain basic elements should remain consistent across any venue. The OC must develop and finalise a detailed local venue lay-out plan and submit that for approval to the FIS Office.

The general layout required for each World Cup venue includes:

- Flows
- Restrooms
- General Services/Signage
- Tribunes (including FIS Family tribune)
- LED Videowall/PA System/Radio Communication
- Competition Management Facilities
- Media Facilities & Public Village (including the FIS Family areas)
- Opening, Closing and Victory Ceremonies areas

See the contractual agreement between the FIS, NSA and Organiser for supporting material during planning process.



→ SUGGESTED ROLE(S): Infrastructure Director & Logistics Director

FLAWS



OBJECTIVE: DEVELOP VENUE FLOW MAP

The flows of the various venue users (athletes, team service, officials, guests / VIPs /sponsors, suppliers, public, etc.) will require careful planning specific to the set-up of each venue.

The flow must be specified and documented from the perspective of each group, including:

- Entry and exit points
- Access control points
- Service areas (food, beverages, restrooms)
- Information Centre

A detailed venue flow map displaying this information must be prepared by the OC to enhance and engage the experience of teams, fans and media.

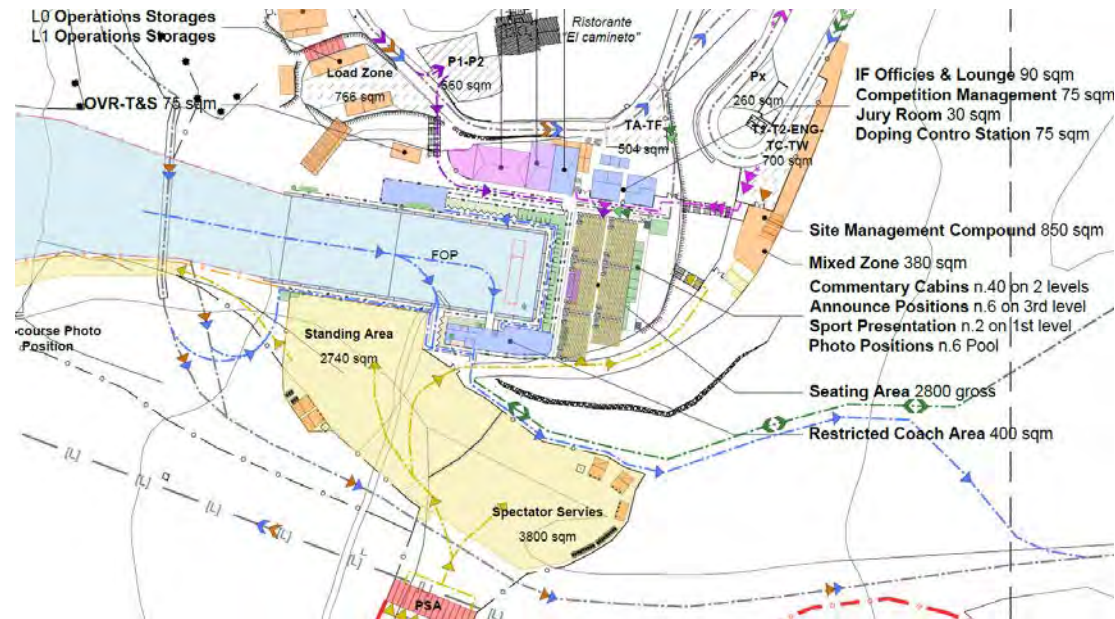

➔ SUGGESTED ROLE(S): Infrastructure Director

RESTROOMS WSC WC

OBJECTIVE: ENSURE ADEQUATE NUMBER OF RESTROOMS

A sufficient number of rest room facilities must be provided, with some including running water and wheelchair accessibility. The different sectors (e.g. team service village/competition management/media /FIS Family areas/Public) will have different needs for restroom capacity and must be serviced accordingly.



→ SUGGESTED ROLE(S): Head of Infrastructure

GENERAL SERVICES WSC

The different sectors of the venue will also have specific requirements for power capacity & power outlets, water, heating, lighting and waste management etc. services that must be carefully analysed and planned. If staging a night event, it is compulsory to have a lighting system on course.

SIGNAGE WSC WC

The various sections of the venue must be well-divided and the sections marked using easily understandable, coherent signage and the same zone designations (colours/numbers) used in the accreditation/access cards.



TRIBUNES WSC

OBJECTIVE: ENSURE ENOUGH TRIBUNES ARE INSTALLED TO PREVENT OVERCROWDING AND SAFETY CONCERNS

The OC will need to provide several tribunes (stands) at the competition venue, including:

- 1) One reserved for important guests and sponsors (FIS Family tribune/stand). The FIS Family tribune should be appropriately sectioned off and offer various seating arrangements, if possible. It should seat ca. 200 guests.
- 2) There shall be a minimum of 10 seats reserved in the tribune for accredited media. WiFi access and power plugs shall be available in these seats. Accessible seats must be provided if wheelchair user journalists are accredited.

The size and capacity of any other tribunes will depend on the local needs, capacity constraints and the estimated number of spectators.



➔ SUGGESTED ROLE(S): Chief of Stadium, Chief Steward, Infrastructure Director

VIDEOWALL WSC WC

OBJECTIVE: USE SITE VISIT TO ASSESS SCREEN SIZE NEEDED



At a minimum, a large video screen must be located in the finish area such that it can be seen by as many spectators as possible. Screen will be used to display start-lists, intermediate times, final results and Broadcast coverage during the event. The position of the video screen must be discussed with and approved by FIS during the site visit.

It should meet the following specifications:

- LED Videowall
- Screen size of min. 53,5 m² in format 16:9
- Pixel distance of 19 mm
- Lightness at 5.000 Nit
- Installed on a mobile unit with turning radius of 180°
- Electronically controlled
- Ability to reproduce a Broadcast video signal

➔ **SUGGESTED ROLE(S):** Logistics Director and Infrastructure Director

PUBLIC ANNOUNCING SYSTEM (PA) WSC WC

OBJECTIVE: ENSURE SYSTEM IS ADEQUATE FOR VENUE SIZE AND THAT A PROFESSIONAL SPEAKER(S) IS HIRED

The organiser should engage professional, skilful and competent announcers and DJs for making the spectators proud to be part of a live international event. It is crucial and important to keep the attention of the on-site public to ensure that they stay until the end of the races.

The specifications of the required sound system and quality level will be provided by the FIS Office.



RADIO SYSTEM



OBJECTIVE: DEVELOP A DETAILED COMMUNICATION PLAN

A radio communications system that works over the entire venue and facilities must be provided for a minimum of thirty users (check with RD) with multiple channels/frequencies for the duration of the event. The OC is also required to communicate to the participating NSAs the legal rules regarding the use of radio communications systems.

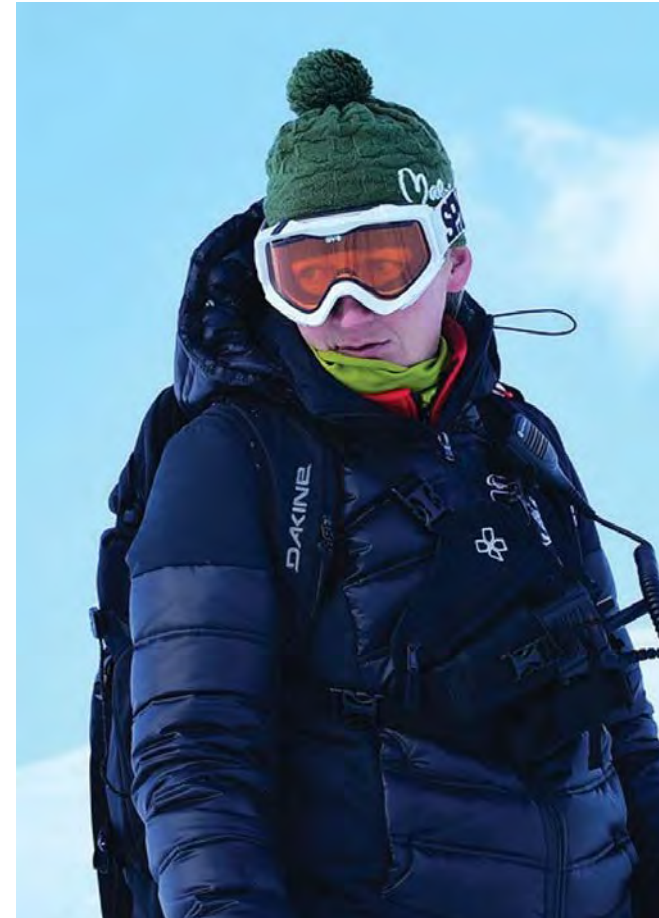

→ SUGGESTED ROLE(S): Logistics Director and Infrastructure Director

PUBLIC VILLAGE WSC

OBJECTIVE: ENSURE ENTERTAINMENT IS ALWAYS AVAILABLE WHEN THERE IS A BREAK IN THE COMPETITION

The OC must allocate space in a dedicated area near the finish area for a public village including a FIS Family area, designed to organise side events (with the participation of special guests, officials, media, sponsors, etc.), and to conduct various activities to stimulate public and media interest.

When possible, sponsors, suppliers, athletes and teams should be incorporated into the entertainment to help enhance the World Cup atmosphere and to enhance the local traditions of the event.

This area could include:

- A public food and refreshment area
- Cultural Events
- A stage for entertainment (eg. Celebrity or musical guests)
- Sponsorship activations
- World Cup youth clinics
- Meet the stars, VIP events
- School campaigns and participation



➔ SUGGESTED ROLE(S): Chief of Stadium, Marketing Director, Media Director, Infrastructure Director, Logistics Director

LOCAL TRANSPORTATION WSC

OBJECTIVE: DEVELOP A DETAILED TRANSPORTATION PLAN

Local transportation needs must be mapped out in a detailed OC Transportation Plan and carefully orchestrated. An OC Point of Contact (POC) for any transport issues must be nominated at least three months in advance, and there must be a Transport Office to coordinate local transportation needs during the event.



For teams and/or VIPs who do not have their own vehicles, the OC may be requested to:

- Assist with transportation from the airport. This service may be charged at cost price, but any charges must be communicated and confirmed in advance
- Transport from the hotel to the lift or finish area(s) and back to the hotel with reserved parking coordinated at each location
- Pick-up athlete after they have completed anti-doping testing (if necessary)

A radio communication system should be used for those in charge of coordinating the local transportation services.

TRAFFIC REGULATIONS

WSC

WC

OBJECTIVE: PARKING LOT REGULATIONS ESTABLISHED AND ROAD CLOSURE PERMITS OBTAINED (IF NECESSARY)



The OC must review the needs for and negotiate with the responsible public authorities the availability of local space and any street closures or non-event related traffic detouring.

Parking at or near the competition venues can often be very confusing, and unclear. Strict regulations should be put in place and parking lots clearly signposted in order to ensure vehicles are well directed to and within the event (team, staff, guests, VIP, etc.). If this is not possible, a well-organised schedule bus service should be offered.

→ **SUGGESTED ROLE(S):** Head of Transportation

OPENING AND CLOSING CEREMONY WSC

OBJECTIVE: EMPHASIZE THE WORLD CHAMPIONSHIPS VALUES, INCORPORATE LOCAL TRADITIONS AND CELEBRATE ATHLETIC ACHIEVEMENTS



The opening and closing ceremonies are an opportunity to bring together athletes, teams, spectators, media, celebrities and community figures around a common goal. While an opening ceremony announces the World Championships, a closing ceremony celebrates success and highlights the competitors' achievements. These activities enable the organiser to bolster community support and to increase the visibility through digital, print and TV.

The organiser should begin the process by selecting a group of staff well in advance to form a planning committee who will be in charge of all aspects related to the activities.

The following areas should be covered during this planning process:

- Agenda
- Master of Ceremony/Speakers
- Venue (location, seating etc.)
- Audio-visual Equipment (microphones, sound system, screens etc.)
- Dress Rehearsal

Review the World Championships Rules for additional protocols related to the winner's presentation, award ceremony and prize money.

➔ **SUGGESTED ROLE(S):** Chief of Protocol, Marketing Director, Media Director, Infrastructure Director, Logistics Director

GENERAL INFO

PROTOCOL

Opening / Closing Ceremony

WSC

- Please refer to the FIS Ceremonies Guidelines
- Protocol elements of Opening Ceremony at a glance:
 - National anthem and raising of host country flag
 - Athletes' parade
 - Official speeches
 - Official opening
 - Paralympic anthem and raising of Paralympic flag
 - Oaths
 - Plans and scripts to be submitted to FIS for approval
 - Official FIS representative

Elements to think about

WSC

- Invitations
- Accessibility
- Duration (especially when ceremony is outdoors)
- "Closing Party"
- Protocol elements of Closing Ceremony at a glance:
 - National anthem and raising of host country flag
 - Entry of nations flags
 - Official speeches
 - FIS anthem and lowering of FIS flag

→ SUGGESTED ROLE(S): Chief of Protocol, Protocol and Victory Ceremony staff

PROTOCOL

Victory Ceremonies & recognition announcement WSC

- Please refer to the FIS Protocol Guide
- VC Field of Play
- Podium designs and measurements to be submitted to FIS for approval
- These areas should be fully accessible
- Medal and Flower/Gift presenters to be identified
- Possible scenarios for VC
 - At competition venue incorporated into the competition schedule (in between races or after completion of all races)
 - At a specific indoor venue in the evening
- Recognition announcement to take place only if VC are conducted after conclusion of all races at a specific venue in the evening
- Leader's box for Alpine Championships

Flag protocol WSC

- OC must display the flags of all the participating NSAs
- Opening/Closing Ceremony, Victory Ceremonies and competition venue
- Approval of national anthems and national flags by each NSA

→ SUGGESTED ROLE(S): Chief of Protocol, Protocol and Victory Ceremony staff

PROTOCOL

Medals and Athletes' Diploma

WSC

WC

- Please refer to the FIS WSC Rules
- Submit design of medals and diploma to FIS for approval
- Mascot or special gift can be considered instead of flowers
- Printing of diplomas on site at the end of each competition day and distribute to team leader the next day

FIS Family stand and lounge

WSC

- "VIP" area – access with accreditation zone 6
- Population with access entitlement 6 listed in the Accreditation Guide
- These areas should be fully accessible
- Warm beverages and snacks/light meals to be offered

→ SUGGESTED ROLE(S): Chief of Protocol, Protocol and Victory Ceremony staff

ATHLETE TESTING WSC WC

OBJECTIVE: ESTABLISH TESTING PROTOCOL, AND STATION SET-UP WITH SELECTED DOPING CONTROL AGENCY

In-competition control tests will be carried out by a specialist Doping Control Agency appointed by FIS in accordance with the FIS Rules/World Anti-Doping Code.

The specialist Agency will identify where unannounced in-competition testing is carried out and make direct contact beforehand with the OC in regard to the logistical arrangements. All Doping Control Officers and chaperones (six-twelve) require the necessary accreditation to access the relevant sectors.

The OC shall provide a Doping Control Station that is used solely as a Doping Control Station for the duration of the event. It should be situated near to the location where the press conference is taking place (finish area, press conference vicinity) and clearly marked.

Any other in-competition doping controls by the National Doping Agencies and their costs remain the responsibility of the national agency, the OC or the NSA depending on the national arrangements.



OCs pays for the doping control services carried out by the specialist Agency and also on-site expenses and arrangements of the doping control officers for meals and accommodation are covered by the OC.

The blood testing station (if applicable) requires an additional secure room for the analysis of the blood samples that can only be accessed by the qualified expert. Where possible the blood testing should take place in the same facility as the doping control station.



Section 2: MARKETING & COMMUNICATIONS

WORLD CUP BRANDING WSC WC

OBJECTIVE: MAINTAIN A CONSISTENT IMAGE ACROSS ALL FORMS OF COMMUNICATIONS



It is effective and consistent branding, combined with a unified “Look & Feel”, that contribute to a strong, positive impact on the World Cup’s marketability and commercial exploitation.

The essence and value of the series need to be captured and conveyed in a new and specific brand identity (e.g. image and design) and incorporated into an overall (event) brand architecture. The long-term objective is to have one distinct, consistent brand identity for the FIS Para Alpine Ski World Cup, giving it more impact and international awareness, reflecting the intrinsic image, ambience, values and style of international ski racing at its highest level.

➔ **SUGGESTED ROLE(S): Marketing Director, Communications Manager, Event Coordinator**

ADVERTISING RULES WSC WC

OBJECTIVE: DEVELOP A PROMOTIONAL PLAN

The current “FIS Advertising Rules” are the basis for advertising possibilities in the competition area, and also the TV area. The OC assigned to carry out an Event by FIS and their NSAs representatives are responsible for the observance of these Advertising Rules.

It is the duty of the OC to implement an effective promotional plan to promote the Event to potentially interested target groups and to secure a well-attended location for the entire duration of the event.

The promotional material to be produced at the cost of the OC may include the following:

- Official event program
- Official event billboard and flyers
- OC press releases



→ **SUGGESTED ROLE(S):** Marketing Director, Communications Manager, Event Coordinator

MARKETING GUIDELINES



OBJECTIVE: DEVELOP A MARKETING PLAN

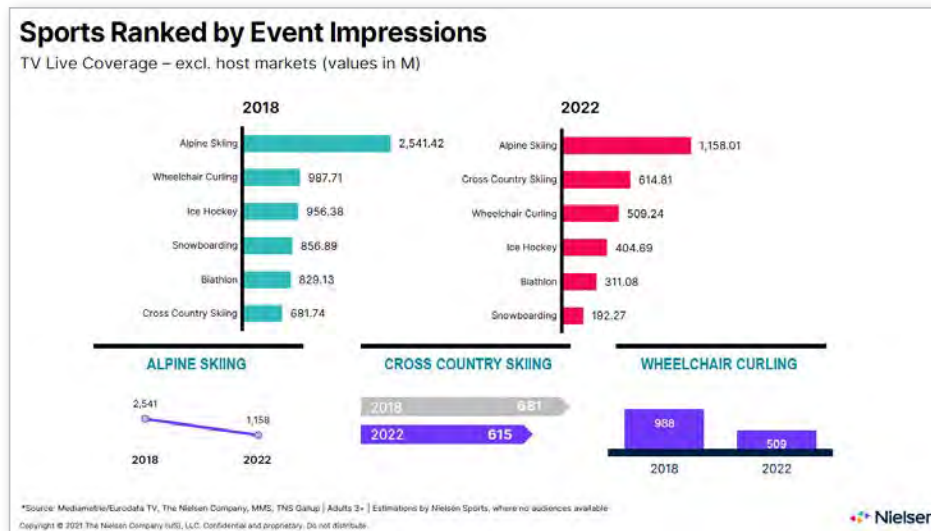

The FIS World Cup provides excellent opportunities for international and national companies to associate their respective brands and products to the FIS properties.

This section provides the regulations and guidelines related to the marketing of the World Cup with the aim of implementing effective international and national /local sponsorship programs. The information herein is essential for the realization of a successful business and marketing plan, required to satisfy all partners' needs.

Marketing objectives to hosting a World Cup/Championships event include:

- Growing the commercial value of the sport
- Achieving the budget goals for a top ski sports event
- Attracting large local and international audiences to meet the sponsors' and partners' needs
- Promoting attractive values, concepts and principles
- Develop a sports festival atmosphere around the competition to attract spectators on site
- Generating opportunities for the participating athletes to become professional and well-known stars

➔ **SUGGESTED ROLE(S):** Marketing Director, Communications Manager, Event Coordinator

SOCIAL MEDIA WSC WC

OBJECTIVE: SUPPORT FIS AND THE SPORT DEVELOPING A SOCIAL MEDIA STRATEGY

Social media should be used as a tool to help achieve communication and marketing objectives for the World Cup/Championships. The FIS Media and Marketing department will be available to help promote the event through the FIS channels. The FIS channels are in English, but the OC is more than welcome to create its own ways to communicate in the official language(s) of the host city.

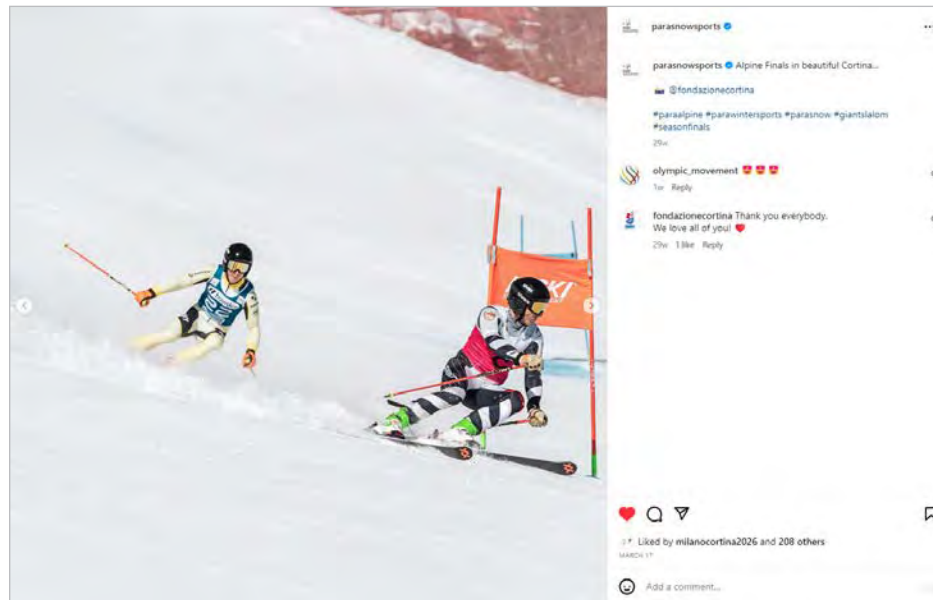

Areas that should be covered in the social media strategy should include:

- Goals and objectives
- Official event name and hashtag
- Content calendar
- Cross promotional opportunities with partners
- Reporting and analysis tools

Remember that social media should be used to engage with fans and to involve them as much as possible. FIS will support you finding out what people want to see and make it as easy to share as possible.

→ **SUGGESTED ROLE(S):** Communications and Digital Media Manager

BRANDING GUIDELINES WSC WC

OBJECTIVE: SUPPORT FIS AND THE SPORT DEVELOPING A SOCIAL MEDIA STRATEGY

Ensure that the brand look & feel is communicated in a professional and consistent manner across all brand touch points, be these the press, television, internet, sponsors, industry, organisers as well as officials and athletes.

Applications of brand guidelines apply to all below sectors:

- Print materials
- Website
- Venue decor and signage
- Advertising and promotion elements
- TV/on screen graphics
- Race gear/equipment
- Gaming
- Vehicle branding

A meeting(s) should also be organised with both the NSA concerned and media rights holder to discuss the digital distribution of the World Cup.



→ **SUGGESTED ROLE(S):** Marketing Director, Communications Manager

BROADCASTING PHILOSOPHY WSC WC

OBJECTIVE: TRANSMIT, IN PICTURE AND IN SOUND, NOT ONLY THE RIVALRY AND THE FACTS BUT ALSO THE EXCITING INTRINSIC DETAILS OF THE SPORT



TV plays a key role in the marketing concept for the Event. The respective host broadcasters (HB) are responsible for high quality TV production in close collaboration with the LOC, and FIS Race Director.

The different courses will have varying requirements for infrastructure and equipment.

However, the latest technology should be leveraged to relay the excitement of the event including:

- A number of standard positions on camera platforms and/or snow platforms
- Specialty camera systems such as the cable camera, the rail camera system, camera cranes, Ski-Doo's, wireless transmission techniques, steadicam, pole-cams, handheld cameras.

Technical TV broadcasting details can be found in the discipline specific broadcasting specifications.

→ **SUGGESTED ROLE(S):** Chief of Race, Chief of Press, Chief of Course Equipment

TV INSPECTION WSC WC

OBJECTIVE: TRANSMIT, IN PICTURE AND IN SOUND, NOT ONLY THE RIVALRY AND THE FACTS BUT ALSO THE EXCITING INTRINSIC DETAILS OF THE SPORT

A minimum of three months prior to the event, the OC must arrange to meet with the FIS staff and the HB to discuss the organisation of TV Broadcasting, to determine camera positions and the height of the platforms as well as to identify any special requirements for TV layouts and operations, start intervals, etc. It is also recommended to schedule an additional inspection closer to the date to incorporate any adjustments as a result of weather conditions.



→ **SUGGESTED ROLE(S):** Chief of Race, Chief of Press, Chief of Course Equipment, Event Coordinator

ADVERTISING POSITIONING WSC WC

OBJECTIVE: WORK WITH PARTNERS TO BUILD THE WORLD CUP IMAGE AND INCREASE ITS BRAND AWARENESS



Together with this manual, the FIS Advertising Rule define the basis that is provided for advertising possibilities in the competition/TV area at each venue. They are binding on the OC for the organisation of the World Cup events.

The OC together with the HB and any marketing agency must clear a final check by the FIS staff and a jury member 48 hours before the competitions. This refers especially to camera positions, the installation of advertising spaces and special advertising elements.

→ **SUGGESTED ROLE(S):** Marketing Director, Chief of Race, Chief of Press, Chief of Course Equipment

COMMENTARY FACILITIES WSC WC

OBJECTIVE: ENSURE TECHNICAL AND ROOM SIZE SPECIFICATIONS HAVE BEEN MET

Commentary positions provided by the OC for TV and radio stations may have to entail, but not limited to the following:

- Positioning ensuring the visibility into the finish
- Sound-proofed
- Sufficient space for a commentator, a co-commentator and an interview partner
- Sufficient desk space for documents, laptop and note-taking
- Heating and 2-3 coat hooks
- Technical installation with TV and data monitors
- Internet connections (LAN or WLAN) and power supply with at least eight power sockets
- Quick delivery system for training, qualification and race results
- Food, beverage and snacks must be made available



→ **SUGGESTED ROLE(S):** Chief of Media, FIS Media Coordinator

MEDIA CENTRE WSC

OBJECTIVE: DELIVER THE BEST INFORMATION TO ON-SITE MEDIA AND PROVIDE EXCELLENT AND SAFE WORKING CONDITIONS

A Media Centre is essential, and is ideally located near the competition area. For World Cups, a media work-room is optional, can be smaller but must be equipped with heating, access to power and reliable Wi-Fi free of charge. It must take into account accessibility for wheelchair user journalists.

It should aim to provide high quality service for:

- Print/digital journalists and photographers
- Reporters/commentators working for rights-holding and non-rights holding TV/Radio broadcasters
- Cameramen/technical staff working for any radio/TV



→ SUGGESTED ROLE(S): Press Manager, Infrastructure Director, Logistics Director

MEDIA SERVICES WSC WC

OBJECTIVE: PROVIDE FAST AND RELIABLE WORLD CUP INFORMATION



For media to effectively cover an Event, it is important that the OC in partnership with FIS provides the following services for media:

- Support the FIS Communications, Media and Marketing departments to produce written features, competition previews and reviews
- The OC shall appoint an official event photographer, to provide pictures to FIS and other relevant stakeholders according to the hosting contract.
- In case there is no capacity to provide local staff to support the editorial and digital media content production, other Para sport events have successfully counted with volunteers from journalist schools in the past. FIS can provide support to this initiative.
- Facilitate the contact between athletes/NSAs and media
- In case there are last-minute programme changes and other important information, it is important to find the best way to distribute this information quickly to media attending the competition

→ SUGGESTED ROLE(S): Press Manager, Communications Manager

POST-EVENT REPORT WSC

OBJECTIVE: ENABLE MORE INFORMED DECISIONS AND MORE EFFICIENT WORLD CUP PLANNING

Post-event feedback is important to any Organiser as it provides the reality check of what went right or what went wrong during the event. Keeping track of feedback is important to progressively improve every year.

World Cup/Championship planning is a complicated procedure that requires flawless communication and teamwork from all staff. Everything needs to be taken into consideration, from the very start.

The following areas should be considered when designing a post-event evaluation:

Evaluation Methods:

- On-site questionnaire
- Online survey
- Staff observation

Sources of Information:

- Spectators
- Athletes/Teams
- Staff and volunteers
- Secret spectators
- Media
- Public authorities
- Sponsors

Review past Post Event Reports for supportive material.

→ SUGGESTED ROLE(S): Chief of Protocol



Section 3: FIELD OF PLAY

COURSE SPECIFICATIONS WSC WC

OBJECTIVE: ENSURING THE COURSE IS CERTIFIED OR HOMOLOGATED

The Homologation Manuals are intended to be a useful resource that should help to formulate a better and correct understanding of the FIS International Competition Rules (ICR) norms for course design, and thus provide the best possible courses for all levels of skiers.

FIS appoints inspectors to carry the special responsibility for taking care of the best traditions in a discipline's course design, and at the same time develop courses that are well suited for all competition formats.

The homologation evaluation includes more than just the course design. The stadium layout and the infrastructure installations are also part of the overall evaluation. The resulting certification represents a FIS stamp of approval indicating that the site is physically capable of accommodating international FIS competitions.

This process is not just a set of standards, but it is a process for certification that provides a forum for constructive discussion between organisers, FIS and inspectors.

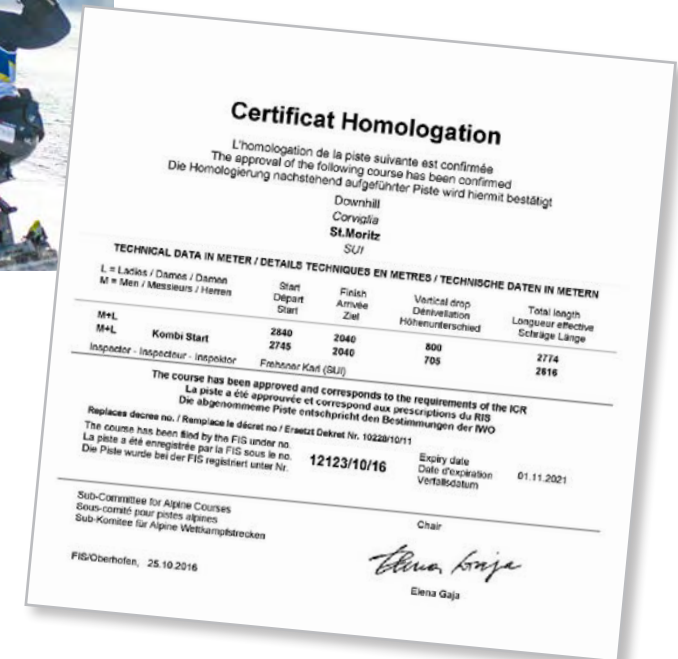

→ SUGGESTED ROLE(S): Homologation Inspectors, FIS Race Director, Chief of Course

COURSE AREAS

(MUST BE REVIEWED FOR EACH EVENT)

Warm-Up Course

Warm-up courses for the competing skiers are required as skiers are normally not allowed to warm up on the competition courses. The warm-up course should be adjacent to but separate from the competition courses and optimally close to the wax cabin area and ending close to the stadium and start area. The warm-up courses should include hills where the competitors can test the kick wax for classical technique races. It is important that the warm-up courses are groomed at the same time and with the same equipment as the competition courses.

Coaches / No-Coaching Zones

The OC must place signs adjacent to the course in these places for coaches and team leaders to observe (non-compliance leads to sanctions!). These locations should also be discussed and shown on a map at the Team Captains' Meeting. Extra grooming width will be considered in certain recommended areas for coaches/ feeding zones.

First Aid Placements

A map must be prepared showing the placement of the first aid stations on the course.

Evacuation Routes

The medical evacuation routes from the course must be carefully planned and shown on a detailed map of the course.

The route planning must be accompanied by detailed planning of safety procedures and roles and responsibilities on the course in case of an emergency.



GROOMING WSC WC

OBJECTIVE: PROVIDE A COURSE THAT IS SMOOTH ACROSS THE ENTIRE SURFACE

Proper grooming for training and competition is among the most important elements of World Cup events.

To best be able to provide an optimal skiing surface, the important elements to consider for an organiser include summer preparations, grooming equipment and attachments, and proper grooming procedures for all possible weather situations.

Warm-up areas should be groomed at the same or similar time as those for competition. This means that to provide optimal conditions for the athletes and coaches, the ski test area, the stadium and the courses should be groomed with separate machines at the same time.

There must be a detailed schedule prepared by the OC for the testing and training times available to the teams in due course before the event. This information must also be communicated in the Team Captains' Meeting.



→ SUGGESTED ROLE(S): Chief of Course, Chief of Course Equipment

GROOMING FOR COMPETITION WSC WC

OBJECTIVE: DEVELOP A WORKING MAP OF THE TRACK AREA

The specifics of grooming for competition will be decided in a meeting after the final inspection by the Jury.

The working map of the track area should be consistently updated and must be developed with the following items:

- Preparation of the start (according to FIS Start Manual)
- Jury positions
- Fencing
- Access routes
- TV camera positions
- Sponsor banner placement



→ SUGGESTED ROLE(S): Chief of Course, Chief of Course Equipment

COURSE MARKING, BARRICADING AND FENCING WSC WC

OBJECTIVE: DEVELOP A DETAILED PLAN OF THE COURSE MARKINGS, BARRICADING AND FENCING



The final fencing should be done the morning before the event (but fencing related to the cable path should be done 2 days before the event) and there must be a final check of course marking just prior to the competition.

The portable fences used inside the finish area should be:

- Made of light material and easy to move and setup
- Stable and sufficiently solid (no plastic bands)
- Easy to store in a space efficient way
- At least a height of 1.25m to stop persons from crossing
- Ideally blue or white (Better for TV picture)

It is also important to make sure people cannot climb through the fence (use mesh or a banner if needed). Lower fences can be used if the purpose of the fence is to stop athletes from skiing into a certain area.

→ **SUGGESTED ROLE(S): Chief of Course, Chief of Course Equipment**

TIMING METHODS AND SYSTEMS

OBJECTIVE: GUARANTEE A HIGH TECHNICAL STANDARD OF MEASURING SYSTEMS, EVALUATION AND ASSURE A CONSISTENT BRAND IDENTITY

The details of the services provided by the FIS Timing and Data Service Provider are specified in the hosting agreement. The advertising possibilities for Data & Timing on the course, on the TV insert and on printed advertising documents only belong to the FIS Timing and Data Service Provider.

Refer to the FIS Timing Booklet and Timing Equipment Guidelines for the FIS Para Alpine Ski World Cup for the complete timing specifications.



→ **SUGGESTED ROLE(S): Chief of Timing and Results Management**

START AREA PREPARATION WSC WC

All information regarding the start area preparation can be found in the **FIS Start Manual**.

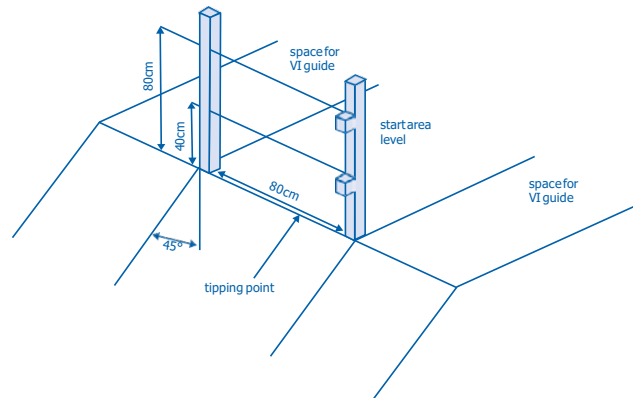

EMERGENCY INFORMATION WSC WC

OBJECTIVE: DEVELOP AN EMERGENCY AND EVACUATION PLAN

The safety of the competitors is one of the main concerns of any event organiser at any level of competition. The OC must also be prepared to provide first aid and emergency services for the spectators or other event participants.

The OC should establish that the following facilities and resources are available to be involved in event:

- On-site facility – triage (place of initial assessment)
- Nearest fully equipped facility, on-site staff physicians
- Nearest Trauma Centre
- Evacuation plan; routes, procedures-ambulances, helicopter, etc

Determine training days as well as event days to be covered with emergency personnel and schedule accordingly. Outline clearly for teams the differences in triage, evacuation and follow-up care between training days and event days.

Organise on-course coverage in terms of 1st responders, event physicians and team physicians.

Typically, Ski Patrol is the 1st response for triage on course injury with the back-up of physicians for severe trauma accidents. They are in charge of the injury site. If they need assistance, they will call for back up. In general, Ski Patrol act as the first response to a downed athlete and they carry standard first aid – ski patrol backpacks. These staff should be placed along the course in areas that will always allow them to have the athlete in view.

Event physicians are the 1st–2nd response depending on the severity of the accident. They should be qualified and well versed in medical emergencies and evacuation procedures. Should a severe accident occur, one of these physicians accompanies the injured to the hospital.

The evacuation of an injured person off the course is the priority once stabilised and Ski Patrol is best trained for this process.

→ **SUGGESTED ROLE(S):** Chief of Medical and Head of Medical

EVENT SUSTAINABILITY

WSC

WC

OBJECTIVE: DEVELOP A VIABLE ENVIRONMENTAL POLICY

It is important to deliver excellent value not only in terms of the conditions for athletic performance but also in terms of cultural and environmental impact of the event.

There are many ways to implement such environmentally conscious practices, that typically include:

- Location of the event – sports facilities
- Equipment (e.g. Energy saving features in electronics)
- Transportation (e.g. Shuttle buses)
- Accommodation (e.g. Hotels within venue walking distance)
- Energy consumption (e.g. Water saving and paper conservation)
- Food, sanitation, and waste management (e.g. Minimal packaging)

While some waste is unavoidable, good waste management can greatly reduce it. The OC must do its utmost to identify ways to reduce production of waste and, to the extent possible, arrange for the possibility to sort and recycle at the venue.

→ SUGGESTED ROLE(S): Chief of Course, Infrastructure Director

SPECIFIC REGULATIONS WSC WC

OBJECTIVE: HAVE A SERIES OF CONTINGENCY PLANS IN PLACE

As it is difficult to control every element of an event, it is important that the OC develops a series of contingency plans to alleviate the impact of unforeseen circumstances.

World Cup Cancellation or Postponement

The factors to be considered for the cancellation or postponement of a competition are:

- Temperature, weather conditions, snow conditions
- Course conditions

The decision to cancel or postpone an event can only be made in consultation with FIS, OC, the NSA and Jury. Upon a decision, the OC must immediately inform the NSAs, the media and post the information on the internet.

Refund Policy

If a competition is postponed, competitors who have paid the entry fee (If applicable) should be allowed to compete in the postponed competition without additional charge. There is no refund if a competitor decides not to participate in the postponed competition.

Refund policy for cancelled competition should be stated in the announcement for competition.

Liability and Insurance

The OC must take out liability insurance for all members of the Organizing Committee.

All competitors participating in FIS events must carry accident insurance, in sufficient amounts to cover accident, transport and rescue costs including race risks. The NSAs are responsible for adequate insurance coverage of all their competitors sent and inscribed by them.

→ SUGGESTED ROLE(S): Chief of Course, Infrastructure Director, Chief of Race, Race Director



Section 4: FINISH AREA

COMPETITION MANAGEMENT FACILITIES WSC WC

OBJECTIVE: ENSURE ALL MAJOR OPERATIONS HAVE THE APPROPRIATE FACILITIES

A Competition Management Facility will normally function as the Operations, Communication and Information Centre between the event's Competition Committee and all participating teams. It should optimally be situated directly across or near the finish line.

At a minimum, include:

- Timing & Results Services
- Announcing
- The Jury
- FIS
- Race Secretariat
- Team Captains' Meeting room (TCM)
- Accreditation room
- Anti-Doping Facility (if not near service area)

A monitor(s) should be made available to FIS/competition management featuring the international signal of the races. Check with FIS regarding the requirements regarding the number of monitors needed and their positioning.

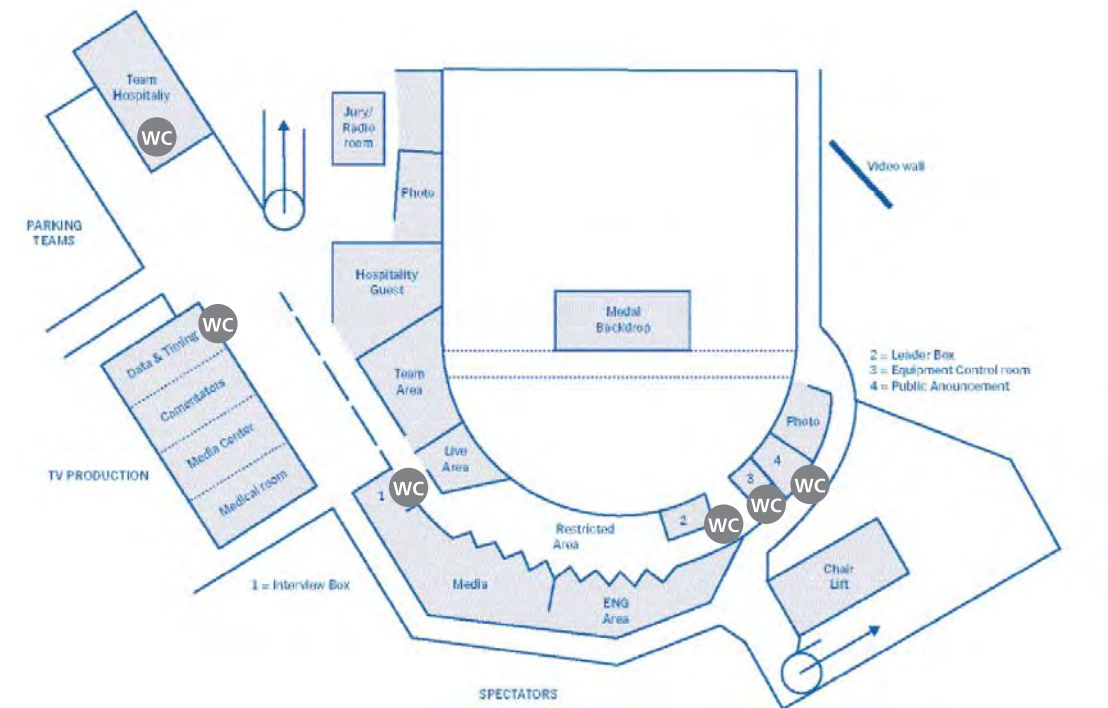

→ **SUGGESTED ROLE(S):** Infrastructure Director, Logistics Director

MIXED ZONES

OBJECTIVE: DEVELOP A MIXED ZONE SET-UP

Immediately after the end of the competition, all athletes are required to go through the Mixed Zone but are not obliged to accept the interview request. Generally, the winning athletes are requested for TV, radio and press interviews. The interview order by client group should be the following respectively:

1. TV
2. Radio
3. Press

It is very important that the OC maintains order in this area.

Ensure the Mixed Zone set-up includes the following guidelines:

- The only path for the athletes to exit from the Finish Area should be through the Broadcast and Press Mixed Zone
- Press Mixed Zone should be long rather than deep, such that as many press persons as possible can be along the fence being able to interview athletes



The design of the Mixed Zone must enable the TV and radio reporters to have interviews with all the athletes during live broadcasts. The space allocation and procedure must follow the existing standards.

A draft version of the Mixed Zone set-up should be ready for the FIS site inspection and details will be discussed and clearly defined during the inspection visit by the FIS Staff, the HB and the international rights holder.

→ **SUGGESTED ROLE(S):** Infrastructure Director, Logistics Director, Race Director, Infrastructure Director

SERVICE AREAS

WSC

WC



In or very near the stadium area, there must be a sufficient number of shelters, permanent buildings or good quality temporary structures, in which teams may store equipment, wax skis and keep warm.

The wax cabins must be provided with:

- Ventilation – adequate for exhausting wax fumes
- Lights and electric power outlets
- Heating
- Locking doors (keys for teams) or security controllers

Each team that has no waxing truck, should have its own cabin but combining more than one team per cabin is allowed if work-space and security requirements permit.

In addition to the cabins, in the athletes' area, a changing room/tent for athletes and as well as the athletes' dining area with catering must be provided. Both areas should have a minimum size of 60m².

Parking space for teams must be provided within a reasonable distance of the cabins. A loudspeaker from the public address system should be placed near the cabins.

ACCESS WSC

OBJECTIVE: AREAS MUST BE SECURED 24/7

The service area must be fenced off and controlled, with teams and athletes given access to this area 24 hours a day. Over-night security must also be provided by the OC for the host broadcaster equipment and vehicle area.

REFRESHMENTS WSC WC

OBJECTIVE: FOOD AND BEVERAGES MUST BE MADE AVAILABLE AT THE SERVICE AREA



The team service staff and athletes must have access to a meal service during the entire day in the athlete and staff dining/recreation area.

Food and beverages must be made available in the FIS Family lounge.

→ **SUGGESTED ROLE(S): Infrastructure Director**

ACCREDITATION SYSTEM WSC

OBJECTIVE: PROVIDE HIGHLY PROFESSIONAL SERVICE AND ENSURE THE CONSISTENCY OF ACCESS CONTROL

The accreditation system is the main tool for controlling access to the specific sectors of the venue, assisting in managing competition operations, and the flow of the different groups at the event, including participating teams, sponsors, officials and the international and national media.

Everyone attending/participating in the event must register for accreditation, including:

- All OC staff and volunteers
- Competition Officials
- All athletes and team staff
- Sponsors, media and guests
- Media, broadcasters
- FIS Staff, Council Members and guests

The access privileges will be displayed on the accreditation cards, given to each individual. The accreditation cards will be individually numbered. Specific codes, colours and numbers are assigned to venues and zones within each venue.

If further access control is required within the competition venue, supplemental credentials will be used, such as armbands and course access bibs. An Upgrade card will give access to the FIS Family areas (zone 6). A ticket may or may not be required (based on an OC decision) to enter the spectator sectors at the competition venue.

Armbands will give access to specific sectors within the venue. During a normal World Cup, the FIS Season bibs are enough.

A system of course access bibs will control access to the competition courses, and to easily identify from a distance, a course user. Athletes, coaches, and service staff are allowed on courses only at certain times and on certain courses.

It is the responsibility of the OC to ensure that all participants have access to the relevant sectors with their accreditation and SACD (where appropriate) to perform their roles, and keep unauthorised people out of secure zones.



→ **SUGGESTED ROLE(S): Accreditation Manager, Head of Volunteers and FIS IT Manager**

ACCESS CONTROL WSC

OBJECTIVE: ESTABLISH SAFETY AND ACCREDITATION PROCEDURES

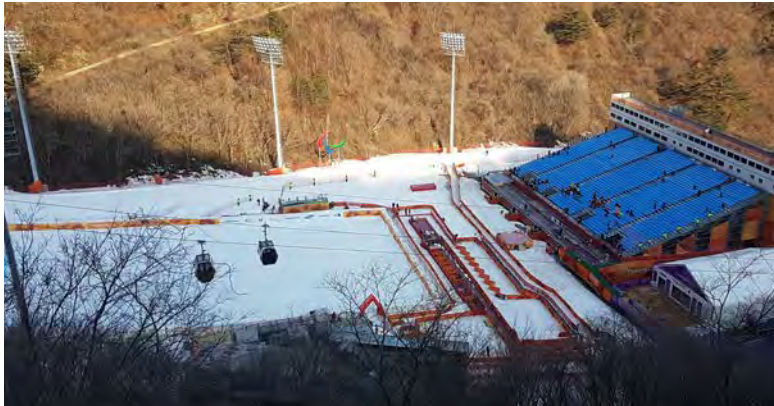

The OC is responsible for arranging 24h security service for the competition venue during the event. Security service personnel must be over 18 years old.

Any individual entering the competition venue will only be allowed to do so if they possess a ticket or a proper accreditation. A group within the OC or a professional entity contracted by them must conduct access control at all entry points in a professional, friendly manner. These points must be carefully determined based on the detailed venue lay-out.

→ SUGGESTED ROLE(S): Infrastructure Director

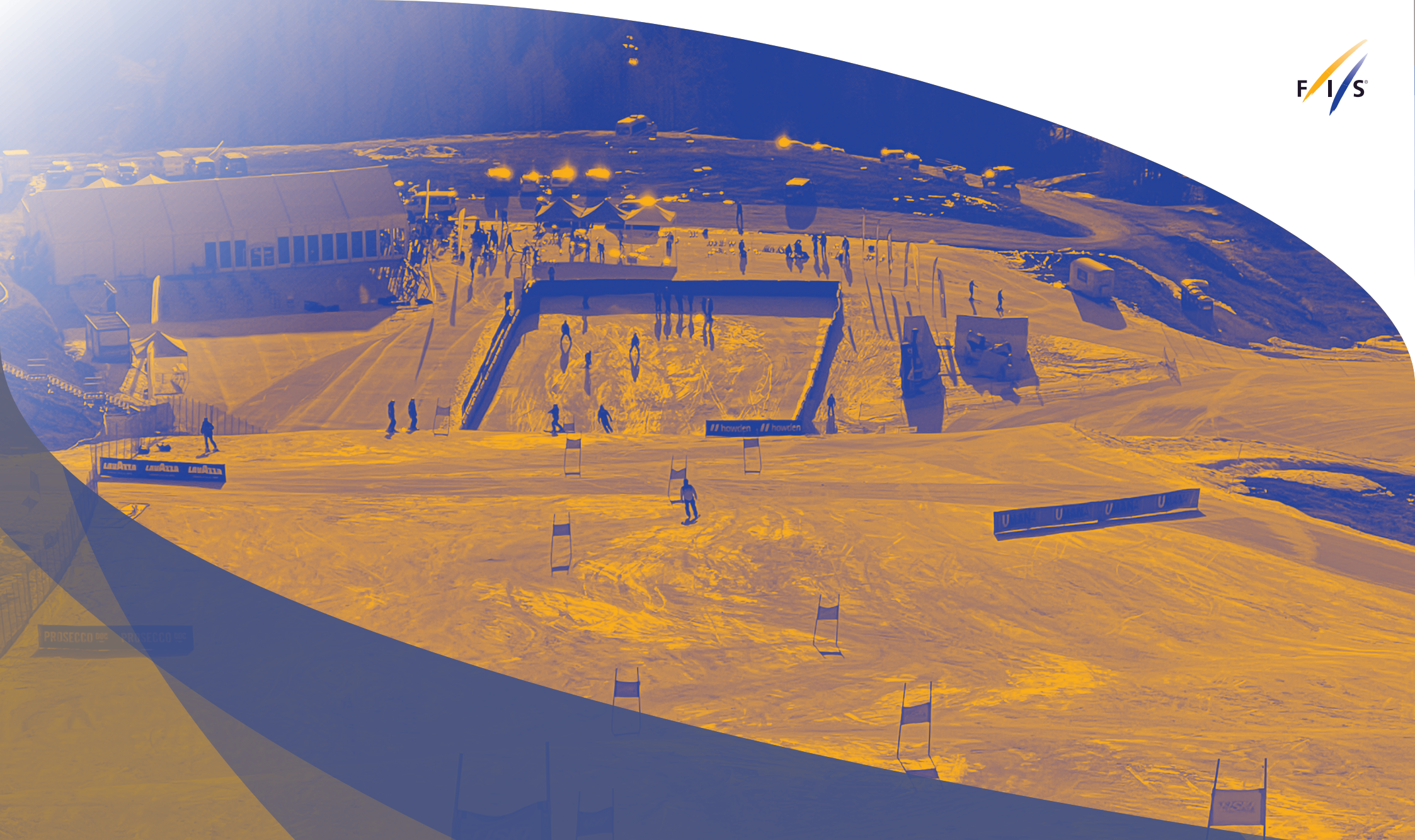

Section 5: ATHLETE SERVICES

QUALITY, COSTS AND AVAILABILITY WSC WC

OBJECTIVE: ENSURE AN ADEQUATE NUMBER OF ROOMS ARE MADE AVAILABLE FOR ALL PARTICIPANTS, INCLUDING MEDIA AND FIS STAFF – AT AN AFFORDABLE RATE

The OC must nominate a staff member to be responsible for coordinating all accommodation arrangements at the venue in question, together with the local tourism organisations.

The OC shall prepare package price for teams/NSA (see FIS International Competitions Rules):

- accommodation half board
- lunch at the venue
- ski ticket and local transportation (if applicable)

For the other FIS World Cup Officials, the OC shall offer:

- Rooms and full board – three stars hotel (basic full board, 1 drink, single rooms) – Consult with FIS
- Race Director, TD, ITOs, Timing & Data Service Provider, FIS staff (if applicable, Media, Marketing etc., final number to be confirmed with OCs)

The participating NSAs are obliged to provide to the OC the final size of their team 6 weeks before the start of the competition (size tolerance $-/+ 10\%$).

Each team has the right (for each gender) to have single or double room as per their request.

Financial conditions including reservation and cancellation process apply as stated in the Official invitation. Travel and accommodation payments can be made by cash or bank transfer (the decision is up to the OC). The payment of the actual hotel bills has to be made by each team in advance or at the time of Check-in. Payment by credit card must be possible.

OCs must ensure that all teams have paid all their bills before leaving.

→ SUGGESTED ROLE(S): Head of Accommodation

TEAM RECEPTION, ATTACHÉS AND INFORMATION WSC

OBJECTIVE: DEVELOP A TEAM INFO GUIDE

The team info guide should include the following information:

- Accommodation and transportation
- Waxing facilities
- Course descriptions with profiles
- Competition program
- Race office contact details
- Time and place of Team Captains' Meetings
- Time and place of Victory Ceremonies
- Any other relevant information

It is important to consult with FIS during this stage to identify what information will be placed in the team info guide – to avoid overlapping work by the OC.

Given the intense competition calendar, it is important for the OC to provide the proper services to ensure that the athletes and teams are able to focus on competing and recovering, rather than worrying about such logistical details:

- A team reception service at each hotel to take care of any urgent concerns.
- An attaché provided free of charge by the OC if warranted by any team or athlete

→ **SUGGESTED ROLE(S):** Logistics Director, Communications Manager

IMMIGRATION INFORMATION

WSC

WC

OBJECTIVE: COLLECT AND DISTRIBUTE IMMIGRATION INFORMATION TO APPLICABLE TEAMS

Depending upon the location of the competition, it may be necessary for select teams to obtain an entry visa in order to participate in the World Cup.

To help with the application process, the OC must contact their country's Customs and Immigration Department to determine the following:

1. Which countries require a visa to enter the host country?
2. The location of the consulate or embassy of those countries requiring a visa

Upon confirming which teams will be fully affiliated with the World Cup concerned, the OC will obtain a letter of invitation template from FIS that will be sent to the teams requiring a visa; with FIS copied on all visa letters.



→ SUGGESTED ROLE(S): Head of Accreditation

DAILY SCHEDULES

The definitive daily schedules and starting times will be established between the OC, HB, other international TV stations and the FIS and published in the Team Info Guide.

The schedules should include at least the following:

- Team Captains' Meetings
- Race Office opening hours
- General starting times
- Official training/service area and opening hours

REGISTRATION



All teams must register their participation through the official FIS online registration system (FPDMS System).

OCs will be provided a log-in access to FPDMS to download the most up to date list of participants and nations.

Proposed registration deadlines are outlined in the FIS ICR and FPDMS.

TEAM CAPTAINS' MEETING

WSC

WC

OBJECTIVE: OUTLINE THE SCHEDULE, IMPORTANT TECHNICAL AND ADMINISTRATIVE ISSUES OF THE WORLD CUP EVENT

The first and perhaps best impression the OC can give to the attending teams and team leaders is at the first Team Captains' meeting.

Usually, the Chief of Competition conducts the meeting and 2–3 persons from each participating team as well as the OC, FIS staff and Jury members. Time and location of the first Team Captains' Meeting and of the draw must be shown in the programme.

The invitations for all other meetings have to be announced to the team captains at their first meeting.



→ SUGGESTED ROLE(S): Chief of Race

Section 6: THE TOOLBOX

ALPINE ORGANISERS CHECKLIST

OC CHAIRPERSONS (SUGGESTED)			
Title	Duty	Name	Contact
Event Chairperson	Oversees all aspects of event		
Lodging / Accommodations / Meals	Athlete/Team services organization and planning		
Transportation	If transportation/parking is required		
Media / Broadcast	Social, Print, TV, etc. Organization (works with FIS)		
Marketing / Sponsorship	Ensures sponsorship and TV relevant branding is set up as agreed (works with FIS and aligns closely with Media/Broadcast)		
Medical	Build Medical plan and schedule Ski Patrol		
Venue Operations / Security	Leads organization of Flow, set up, tear down and security for Public, Athletes, and staff. Create proper credentials		
Banquette, Protocol and Ceremonies	Responsible for all protocol elements, including Opening, Closing and Victory Ceremonies and other official events		

COMPETITION COMMITTEE			
Title	Duty	Name	Contact
Chief of Race	Executes all aspects of the competition	See "Competition Staff" Tab	
Race Secretary (Race Administrator)	Administrates registration and results		
Chief of Course	Prepares and maintains competition venue and directs crew		

APPOINTED OFFICIALS			
Title	Duty	Name	Contact
FIS Race Director	Oversees all aspects of event representing FIS and Athletes	See "Competition Staff" Tab	
Technical Delegate	Oversees all aspects of the competition representing FIS		
Referee	Represents the Athletes		
Assistant Referee	Only used in speed events representing the athletes		

COMPETITION INFORMATION AND AGREEMENTS			
Item	Description	Responsible party	Done?
Required Contracts	FIS/Venue/etc.		
Competition Trail Homologation up to date	FIS		
Bank transfer information	For payment of race fees from each nation.		
Announcement / Invitation posted	See FIS Invitation Template.		
Committee Structure / Job assignments	See Structure tab.		
Anti-Doping	Requirements met and appropriate testing facilities supplied.		
General Public and Observer Plan	Stadium, Flow, Security, etc.		
Medical Plan	Required and must be approved (Local, Regional, Air Transportation locations)		
Ski Patrol	Set up with Mountain Operations and to be approved by CoR, TD, and RD. Ideal: 2 stations with 2 patrollers and 1 sled at each.		
Grooming / Surface preparation Plan	To produce best surface possible, start preparing roughly 5–10 days in advance. Work out a regular grooming schedule with dedicated machines.		
Competition Schedule	Work with RD and TD on this.		
(weather or snow) Conditions emergency plan	Plan for alternate start locations, times, grooming and track prep personnel.		
Travel arrangements for FIS Delegates	Per FIS Contract.		
Site Visit Scheduled	Required for new venues and must be done 3–6 months before the competition.		
Training / Warm up venue	Similar terrain to race hill preferred. Located in vicinity of race venue.		
Lift Schedule	Make the proper contacts for approval.		
Lift ticket: Athletes	Athlete tickets are at a cost.		

Table continues on the following page.

Continuation of the table from the previous page.

COMPETITION INFORMATION AND AGREEMENTS			
Item	Description	Responsible party	Done?
Lift Ticket: Volunteers, Coaches, Staff, broadcasting staff	Staff/Volunteers tickets are typically given to OC.		
Lunches	Pack lunches for volunteers and Jury on the hill. Delivered on hill or handed out in the morning before lift is loaded.		
Bibs	OC must provide bibs for all athletes. FIS to approve the design before production.		
Victory Ceremony medals and gifts	Proper number with spares for ties/guides. World Cup medals to be provided by OC. World Championships by FIS.		
Opening / Closing ceremony	Build excitement for the event and showcase athletes, staff and venue. Celebrate achievements for the Closing.		

RACE HEADQUARTERS			
Item	Description	Responsible party	Done?
Space for Administration	Long table with room for paperwork		
Space for TCM	Each country will typically have 2–3 Representatives. Table for Jury		
Officials Paperwork	Copies of required competition docs and forms (E-Timing log, Hand timers logs, Ref reports, Start log, finish log etc.)		
Clipboards	For Start/Finish Ref's, Gatekeepers, Hand timers		
Gatekeeper supplies	Gate Judge cards and pencils in Plastic bags to protect from water damage		
Computers	As required for competition administration staff		
Copier	Important for results and start lists (1 ream of paper per day)		
Wireless network / Internet	For posting results and downloading registrations		

COMP VENUE			
Item	Description	Responsible party	Done?
A-Net	Per trail Homologation requirements and Jury Inspection		
B-Net			
C-Net/Pop Fence	For containment of Media, Medical, on hill staff staging		
Padding / Willy Bags	Per Homologation and Jury inspection		
Radios	Based on what is needed for effective and efficient communication. Recommended 25+ radios: Jury (possible back up radios issued) Course crew and slipper leads. Start, finish, timing, RA, banner/ branding team, etc. ...		
Start Area	See FIS Start Area Instructions Manual. Start shelter (tent or permanent building) compulsory to keep starting athletes dry and warm in inclement weather (recommended 4x5 meters).		
Timing Equipment	Provided by the FIS Service Provider. The OC to provide support as per Timing Equipment Guidelines for the FIS Para Alpine Ski World Cup.		
Start Clock	Compulsory for some events as per ICR		
Intermediate timing locations	Based on trails cabling and event.		
Yellow Flags	Per Course set. Have 1 per location and a spare at start.		
Timing House	Heated space to fit a minimum of 5 people with the ability to see the finish line.		
Finish Corral/ Fence	Size per rule book		
Scoreboard and Official Notice Board	A location outside of finish area where athletes can gather and watch the times. Also notice board for time changes, DSQ's, and other notices.		
Score sheets	Filled out night before or morning of event with athlete names, country.		
Scoreboard Supplies	Extra markers and tools so times can be written even in inclement weather.		

Table continues on the following page.

Continuation of the table from the previous page.

COMP VENUE			
Item	Description	Responsible party	Done?
Scoreboard Stapler	Construction or heavy duty stapler to hold score sheets to board or building and also post DSQ's and other official posts.		
PA System	Music and announcements. Also times and athletes at Start/Finish.		
Broadcast Compound	OB-Van parking with Power, dedicated internet, maximum 100 meters from the finish area.		
Victory Ceremony	Showcase the day's winners.		
Flower Ceremony	Only if the Victory Ceremony will take place outside the competition venue. WSC only.		
Possible athlete / staff / general public social gathering	Help build relationships during the event and create memorable social experiences.		
Opening and Closing Ceremonies	WSC only: Showcase the highlights of the event and build excitement for the success of the athletes and the sport.		
Restroom Facilities	If no lodge is available, Accessible Portable toilets requested.		
Drills / wrenches	For course and protection repair/stationed strategically at start and on hill (10+ total drills with 2 batteries per and # of wrenches dependent on whether or not screw bases are used. If so, 10–30 wrenches also stationed).		
Dye and Sprayers	Red for Finish, Dark blue for marking track, gate location, and abrupt terrain changes. 4 packs recommended for efficiency in set up and touch up.		
Gates and Panels	Per Event (Single gate or with outside gate) with spare (individual pole with outside gate Example: DH 100 (25 Spare), SG 100 (25 Spare), GS 275 (30 Spare), SL 150 (30 Spare)		
Measuring Wheel	To measure length of track. Leave at start.		
Rakes / Shovels	Square blades for track work (10+), Grain Scoop to remove snow from track (20+) Rakes to smooth and clean track (20+) Station tools at start and strategically on hill.		

Table continues on the following page.

Continuation of the table from the previous page.

COMP VENUE			
Item	Description	Responsible party	Done?
Venue wiring	Timing: Checked, Double checked, and triple checked. Check wire resistance and continuity, all connections and pedestals, and test with timing hardware no closer than 48 hours before event. Set timing up again and test 12 hours before event. Electricity: Required generator and burry or hang all extension cords.		
Assorted tools chosen by Chief of Course	Could be hammers, wedges, chemical spreaders, etc.		

TIMELINE

TIME: 1 TO 2 YEARS	
Item	Description
General Layout	<ul style="list-style-type: none"> Finalise and submit venue layout plan to the FIS Office with zones/areas clearly marked. Involve every group in the planning process of entry and exit points, access control points, pick up/drop off zones, various service areas and information points
General Services	<ul style="list-style-type: none"> Carefully analyse and plan different needs and requirements for power, water, heating, lighting, waste management and restrooms in the different sectors (e.g. team service and public village).
Accommodation	<ul style="list-style-type: none"> Appoint Head of Accommodation. Follow accommodation requirements according to the FIS ICR. Make secured ski storage area near the competition venue and/or the team accommodation available.
Transportation	<ul style="list-style-type: none"> Develop Transportation Plan. Analyse availability of parking at/or near the competition venues. Discuss traffic situation with the public authorities.
Branding	<ul style="list-style-type: none"> The colour, layout grid, typography, charts & tables are according to the FIS Brand Book. The FIS logos are used appropriately. All publications must be approved by FIS.
Environment	<ul style="list-style-type: none"> Take environmental considerations regarding transportation, energy consumption, food & accommodation, water management & sanitation, and waste management. Put recycling system in place. Consider local products for the food & beverages services.
Team Service	<p>Publish in the Team Info Guide issued in middle of September by FIS the following information concerning:</p> <ul style="list-style-type: none"> Accommodation Accreditation Transportation Waxing facilities Course descriptions with profiles Competition program
Media Centre	<ul style="list-style-type: none"> Appoint Chief of Media.
Broadcasting	<ul style="list-style-type: none"> Agree to broadcast scope based on FIS Broadcasting Requirements.
Marketing / Sponsorship	<ul style="list-style-type: none"> Allocation of rights and protected categories, etc. are defined as per hosting agreement.

TIME: 6 MONTH	
Item	Description
Production company for the event and Ceremonies	<ul style="list-style-type: none"> — The venue producer and main announcer are appointed and approved by FIS. — Key responsibilities are assigned. — Discussions started on the Ceremonies concept. — Music used at the venues and during ceremonies must have rights clearance.
Accreditation	<ul style="list-style-type: none"> — Appoint responsible person for accreditation and workforce. — Suppliers of software and materials identified. — Accreditation plan and website are set up.
Broadcasting	<ul style="list-style-type: none"> — Broadcast site visit to confirm final production plan.

TIME: 3 MONTH	
Item	Description
Radio Communication system	<ul style="list-style-type: none"> — Develop communication plan. — Provide radio communications system with multiple channels/frequencies for a minimum of 30 users. — Communicate legal rules regarding the use of radio communications systems to the Teams.
Transportation	<ul style="list-style-type: none"> — Nominate OC Point of contact for transportation issues. — Set up Transport Office. — Put a communication system among those in charge of the transportation systems in place. — Make transportation from the nearest airport available to athletes without own vehicles. — Communicate the charges for this service.
Extreme Weather plan	<p>Have the following precautions been planned for:</p> <p>Cold temperatures:</p> <ul style="list-style-type: none"> — where are measurements taken what are exact limits — who makes decisions — extra blankets for skiers at finish indoor facilities for volunteers — addition warm spot of the volunteers (to avoid too big crowd in the finish tent) <p>Heavy snow:</p> <ul style="list-style-type: none"> — extra volunteers — extra grooming machines extra fore-runners — timing of grooming — timing of forerunners interface with Jury — interface with venue/site management interface with transportation <p>Wind:</p> <ul style="list-style-type: none"> — extra stadium and course volunteers — timing of grooming — methods of attaching banners and securing fences <p>Rain:</p> <ul style="list-style-type: none"> — volunteer preparedness (rain-coats) — extra food and warm clothes — indoor facilities for volunteers

Table continues on the following page.

Continuation of the table from the previous page.

TIME: 3 MONTH	
Item	Description
Accreditation	<ul style="list-style-type: none"> — Accreditation (incl. lanyard) design is submitted to FIS for approval — Athletes, team staff, OC staff, sponsors, FIS, media, broadcast and guests are registered (online, via excel import or manual entry directly into FIS Accreditation System) — Approval process for all organisation types (FIS, LOC, NSA, MEDIA (local and international)) — Privilege Matrix for volunteers and security, based on functional areas — Ensure access control and entitlements are correctly reflected on Accreditation Card (including transportation, dining) — All accreditations are printed; bibs produced; procedures created in case of accreditation loss
Team Services	<ul style="list-style-type: none"> — Appoint a senior point of contact for athlete and team services; Set-up team reception service at each hotel.
Attachés / Interpreters	<ul style="list-style-type: none"> — Make enough attachés available to each team on race days
Info on immigration and VISA requirements	<ul style="list-style-type: none"> — Send letter of invitation to teams requiring visa; Copy FIS in on all these letters.
Medical Services	<ul style="list-style-type: none"> — Appoint the Head of Medical and Rescue Service — Make the following facilities available for the event — On-site facility – Triage (place of initial assessment) — Nearest fully equipped facility, on staff physicians — Nearest Trauma Centre — Evacuation Resources; ambulances, helicopter, etc. — Put a back-up system in place — Establish an Evacuation Plan — Organise on-course coverage expecting several incidents at the same time — Develop a schedule for training and competition days — Outline for the teams the differences in triage, evacuation and follow up care
Anti-Doping Testing	<ul style="list-style-type: none"> — Agree on the logistical arrangements with the specialist Doping Control Agency — Prepare accreditation for the Doping Control Officers and chaperones — Select 8 chaperones according to the following requirements: Speaking English (Additional languages) preferable
Protocol	<ul style="list-style-type: none"> — List of LOC invited guests submitted to FIS — Process of flag and anthem approval is started with the NSAs — Design of Participation diplomas is sent to the FIS for approval — FIS Family Stand and Lounge plan submitted to FIS for approval. Level of catering services at the FIS Family Lounge clarified

Table continues on the following page.

Continuation of the table from the previous page.

TIME: 3 MONTH	
Item	Description
Protocol and Ceremonies production	<ul style="list-style-type: none"> — A meeting is arranged 2–3 months prior to the event pertaining to the event and ceremony production; inviting all related personnel are present — The budget is approved — The operational plans for Opening, Closing and Victory Ceremonies are sent and approved by FIS. — Opening, Closing and Victory Ceremonies scripts are sent and approved by FIS. — Medal and gift designs are approved by FIS. — Podium design is approved by FIS. — Music for Victory Ceremonies is identified and related rights are cleared. — Backdrop built and set up according to the Victory Ceremony plan.



TIME: 1 MONTH	
Item	Description
Staff and responsibility	<ul style="list-style-type: none"> — Volunteers are properly informed and trained in each functional area — All main roles are assigned and approved by FIS and responsibilities are clear to assigned personnel — Contacts of responsible personnel are shared
Flow	<ul style="list-style-type: none"> — Entry to the venue takes place through an accreditation controlled area — Train controllers so they can direct people to the correct areas
Signage	<ul style="list-style-type: none"> — Make signage easily understandable and coherent throughout the whole venue — Use the same designations for the signage as on the accreditation cards
Tribunes	<ul style="list-style-type: none"> — Family Area is duly prepared. — Place the photographers' tribune with a good view on the finish area — Design the photographers' tribune designed according to the recommended requirements: <ul style="list-style-type: none"> — with a depth of 50 cm — a height of 40 cm per step — a total width of 12 m
Competition Management facilities	<p>Timing & Results Services</p> <ul style="list-style-type: none"> — (Size: Approximately 30 m²) — Situated above or close to the finish line, with clear Room for 5–6 computer workstations along the windows facing the finish line — Space for equipment and tables for intermediate — Timing operators and TV graphics interface — Space for a photo finish camera and monitor (if applicable)
Announcing	<ul style="list-style-type: none"> — (Size: Approximately 10 m²) — Must have a great view of the whole stadium or field of play, as well as racks for various pieces of equipment (sound system, mixer etc.) — Announcer must also receive the TV signal and electronic information from the race, on computer terminals in the room (CIS) — Space for working places including power and internet connection
Jury	<ul style="list-style-type: none"> — (Size: Approximately 30 m²) — Clear view over the course (if possible) — Work and meeting area including a PC & printer, Internet, connection to the live feed of the HBC, video and TV monitor, power extension cable, hooks and shelves for ski — equipment and clothing, small refrigerator and table for food It is important for the integrity of the Jury work that this room is secure, quiet and separate from any other activities

Table continues on the following page.

Continuation of the table from the previous page.

TIME: 1 MONTH	
Item	Description
FIS	<ul style="list-style-type: none"> — (Size: Approximately 20 m²) — Work and meeting area, including a PC & printer, Internet, video and TV monitor (including live signal from HBC), power extension cable, hooks and shelves for ski equipment and clothing, small refrigerator and table for food — A close connection to the Jury room would be ideal
Race Secretary	<ul style="list-style-type: none"> — (Size: Approximately 35 m²) — Work area including one (1) high capacity (100 pages per minute) copy machine, and printer, telephones, and standard office supplies and equipment — This space should also contain information boards for posting of information and results
Anti-Doping Control Station	<ul style="list-style-type: none"> — Situated near to the location where the press conference is taking place and clearly marked <ul style="list-style-type: none"> — The station must consist of: <ul style="list-style-type: none"> — a waiting area — a working room — toilets (women and men) — Set-up according to the Doping Control Station Requirements — Make canned or sealed bottled refreshments (mineral water, soft drinks, fruit juice, etc.) available in the waiting area — Check that drinks only contain water, minerals, sweeteners and carbohydrates
Mixed Zone	<ul style="list-style-type: none"> — Set up finish area in a way that the only path for the athletes to exit is through the Broadcast and Press Media Mixed Zone — Provide each broadcaster with own production facilities with a platform (size tbc with HB) upon check with FIS — Set up Press Mixed Zone in a long rather than deep way — Use appropriate metal fencing (height to be adjusted and appropriated for sitting athletes)
Team Captains' meeting	<ul style="list-style-type: none"> — Have seating for up to 70 people (2–3 persons from each participating team) — It should have audio (microphone) and presentation tools (video/laptop projector and screen) available, Internet connection as well as copy machines for copying and distribution of start lists after the meeting. — The location of the TCM will depend on the venue overall schedule and the housing situation for the participating teams. If most of the teams stay in the same hotel, the meeting can be held at the hotel. If this is not the case, the best location for a meeting is at or near the stadium, preferably following the official training or competition.

Table continues on the following page.

Continuation of the table from the previous page.

TIME: 1 MONTH	
Item	Description
Commentator facilities	Set up the commentator boxes according to the following requirements: <ul style="list-style-type: none"> — Visibility into the finish — Sound proofed — Sufficient space for a commentator, a co-commentator and an interview partner — Sufficient desk space for documents, laptop and note-taking — Heating and 2-3 coat hooks — Technical installation with TV and data monitors Internet connection and phone line upon request — At least 8 power sockets — Food & Beverage — Quick delivery system for training, qualification and race results planned
Wax cabins	<ul style="list-style-type: none"> — Ventilation system – adequate for exhausting wax fumes lights and electric power outlets — Locking doors (with keys for teams) or security controllers
Athlete Area	<ul style="list-style-type: none"> — Make changing rooms/tents (60 m²) for athletes available — Provide a FIS dining/recreation area (60 m²) — Grant access to this meal service to the athletes and team service staff during the entire day — Make parking spaces for teams available within a reasonable distance of the cabins — Place a loudspeaker of the public address system near the cabins — Make restrooms (separate for men and women, with adequate capacity and opportunity to wash hands) available inside or adjacent to the wax cabins and the Athletes' Area — Fence off service area adequately — Control access — Instruct overnight security — Make food and beverages available at the service area
Giant screen / score board	<ul style="list-style-type: none"> — Work with sponsor to place the large video screen in the finish area/stadium
PA System	<ul style="list-style-type: none"> — Install PA/sound system
Protocol and Victory Ceremonies	<ul style="list-style-type: none"> — Area for Victory Ceremony briefings identified — Presenters' Catalogue is sent to FIS — Process of assigning Presenters to Victory Ceremonies is under way — Medals, lanyards and gifts are produced — All flags and flagpoles (flag trapeze, etc.) are produced/purchased — Podium, backdrop and other Ceremonies (e.g. lectern for the Opening Ceremony) elements are produced

TIME: 1 WEEK	
Item	Description
Branding and Marketing	<ul style="list-style-type: none"> — All branding elements are according to FIS guidelines — All marketing requirements are met and approved by FIS — Establish procedure for "Crisis Communications"
Media Centre	<ul style="list-style-type: none"> — Wi-Fi access is sufficient for large number of users, extra paid internet service is available — Test all electronic equipment (printer, TV, etc.) before the event — Catering and cleaning are scheduled — At least one IT technician is available during the operation hours 8am-11pm — Camera repair service is arranged for the period of the event — Parking is reserved for accredited media
Media Service	<ul style="list-style-type: none"> — Check all displays (including water bottle, etc.) that no labels allowed during the press conference — Set up "Whats App" group for changes/alerts — Establish interpretation service and set up photographer pool — Parking is reserved in front of media accreditation centre — Arrange media welcome presents and welcome bags (cooperation with marketing department) — Media accreditation requests procedure is communicated and validated
TV / Radio Service and Infrastructure	<ul style="list-style-type: none"> — Commentary Position is set up — All cables are checked and set up properly — All lighting is tested in TV compound/IBC/Control room — The time and place for press conference is communicated clearly — Media photo accreditation – the photo markers (sent by FIS) are distributed — TV sound and picture is checked with the host broadcaster — Hot spot is set up in the stadium for wireless access and login info is shared
Accreditation	<p>Set up of accreditation office, including:</p> <ul style="list-style-type: none"> — Training of staff and volunteers — Checking adequate internet access — Processes in place for dealing with changes/on site accreditations — Setup and testing of computers, printers, ensuring enough materials and equipment, etc. — Sign off, printing of accreditation cards — Advisable to have IT staff member on site, available to deal with any connectivity issues
Protocol	<ul style="list-style-type: none"> — Opening and Closing Ceremony scripts are finalised and final FIS Family Area seating is developed together with FIS — Participation diplomas are printed and ready for distribution

Table continues on the following page.

Continuation of the table from the previous page.

TIME: 1 WEEK	
Item	Description
Victory Ceremonies	<ul style="list-style-type: none"> — Positions and roles presenters, winners, tray bearers, photographers, control guards, volunteers and other responsible staff are clear. Operations are coordinated between OC victory ceremony staff, TV broadcasters, photographers, producers, announcers, mixed zone managers and FIS staff — Victory Ceremonies rehearsals are held with all stakeholders — Victory Ceremony staff is briefed with regard to the uniform rules during Ceremonies — All approved National anthems and flags for all competitors are ready. OC has the rights to play the anthems
Insurance and Cancellation	<ul style="list-style-type: none"> — The required insurance is taken out and present to the Technical — Delegate before the first training day or competition — The cancellation procedure is communicated to related personnel
Miscellaneous	<ul style="list-style-type: none"> — Check with accommodation department for media hotels — Prepare procedure in case of accreditation loss — Make sure enough reserved parking for accredited media — Internet connections are available in media hotels — Clear and visible signage for media parking and shuttle

COMPETITION STAFF AND OFFICIALS

COMPETITION OFFICIALS					
Position	Licensed?	#	Name	Phone #	Email
Technical Delegate	Yes	1			
Race Director	Yes	1			
Race Administrator		1			
		1			
Chief of Race	Yes	1			
Chief of Course	Yes	1			
Referee	Yes	1			
Assistant Referee	Yes	1			
Course Setter AM		1			
Course Setter PM		1			



TIMING CREW					
Position	Licensed?	#	Name	Phone #	Email
Chief of Timing	Yes	1			
Asst Timer		1			
Asst Timer (2)		1			
Start Hand Timer (1)		1			
Start Hand Timer (2)		1			
Finish Hand Timer (1)		1			
Finish Hand Timer (2)		1			
Scoreboard Scribe		1			
Course Setter PM		1			

RACE SUPPORT					
Position	Licensed?	#	Name	Phone #	Email
Runner		1			
Bib collection		1			
Banners		1			
Lunch Maker		1			

GATE KEEPERS					
Position	Licensed?	#	Name	Phone #	Email
Head Gate Keeper		1			
1					
2					
3					
4					
5					
6					
7					
8					
9					
10					

RACE CREW/ SLIPPERS					
Position	Licensed?	#	Name	Phone #	Email
Skilled 1		1			
Skilled 2					
Skilled 3					
Skilled 4					
Skilled 5					
Skilled 6					
Skilled 7					
8					
9					
10					
11					
12					
13					
14					
15					
16					

BUDGET

VENUE		
Description	Income	Outcome
Ski slope preparation		
Ski slope renting		
Safety		
Infrastructure		

RACE OFFICE		
Description	Income	Outcome
Timing & Scoring		
Race office material		
Support / Volunteers		
Teams		
Staff		
TD		
Sanctioning fee		

ACCOMMODATION / FOOD / SKI TICKETS		
Description	Income	Outcome
Teams		
Officials		
Volunteers		
FIS		

TRANSPORT		
Description	Income	Outcome
Teams		
Officials		
Volunteers		
FIS		
FIS President, Secretary General and/or FIS Council Members		

MEDICAL		
Description	Income	Outcome
Ski Patrol		
First aid		
Helicopter		
Anti-doping		

COMMUNICATION		
Description	Income	Outcome
Marketing/PR		
Side events		
Souvenirs		
Promotion material		
Support – Donations		
Support – Sponsorship		

ACCREDITATION		
Description	Income	Outcome
Production materials		

PROTOCOL		
Description	Income	Outcome
Participation diplomas		
Flagpoles and flags (of participating nations & protocol set)		
FIS Family Lounge (if applicable) and refreshments		
Lectern for official speeches and AV (if applicable)		

CEREMONIES		
Description	Income	Outcome
Backdrop and podium		
Medals and mascots / gifts		
Trays		
Flagpoles and flags		

MISCELLANEOUS		
Description	Income	Outcome
Currency exchange		
Other / Security		

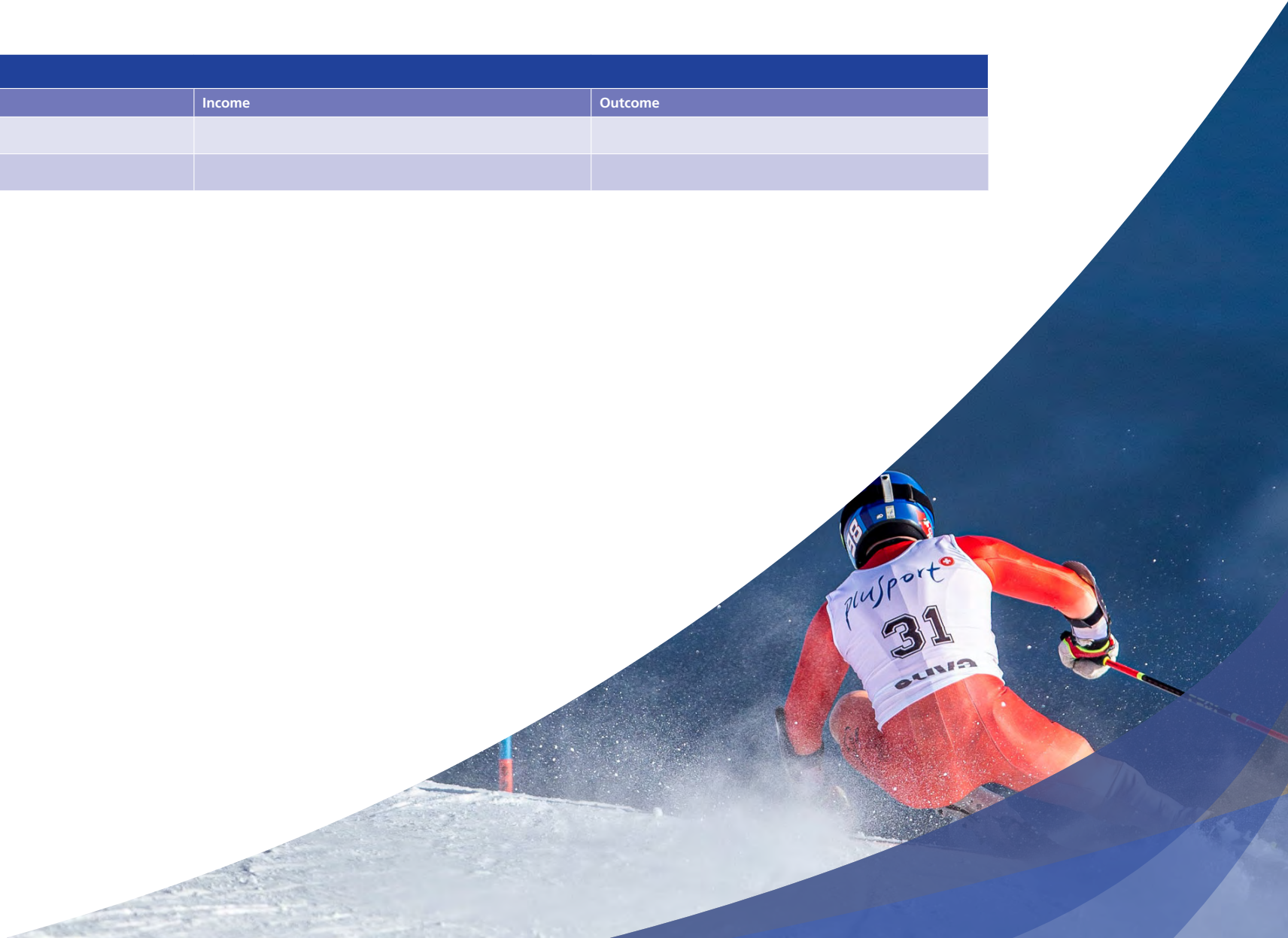



**INTERNATIONAL
SKI AND SNOWBOARD
FEDERATION**

Blochstrasse 2
CH-3653 Oberhofen am Thunersee
Switzerland

Phone: +41 (0)33 244 6161
E-mail: ParaAlpine@fis-ski.com
Website: fis-ski.com