



# **FIS PARA ALPINE SKIING START AREA INSTRUCTIONAL MANUAL**

**AUGUST 2023**

Para Alpine Skiing athletes have varying impairments, which require careful design of Start Area.

It is important that the criteria listed below are implemented in the Start Area design so that all athletes have a chance at fair competition.

**Start Area criteria:**

- The Start Area must be prepared several days in advance to allow the snow to be set. A knowledgeable person shall accompany the snowcat operator to construct the start.
- The start ramp must have an angle of approximately but not greater than 45 degrees, steep enough to give the racer rapid acceleration. If the slope is relatively flat the minimum height of the start ramp must be two meters (2m.)
- The 'tipping point' is at the forward edge of the start posts.
- The Start Area consists of the start gate, start tent and entry ramp. This area should be as level as possible to minimise snow shovelling.
- The start corral is located behind this area and is a special roped off area for trainers, team captains, service personnel etc., to work with the competitors who are waiting to start without being interrupted by the public. An adequate shelter must be prepared for the competitors waiting for the call to start.
- The entire Start Area should be cordoned off with Spectator (Spec) fencing or B-Net to prevent the general public from entering the area and damaging the start area or injuring themselves.

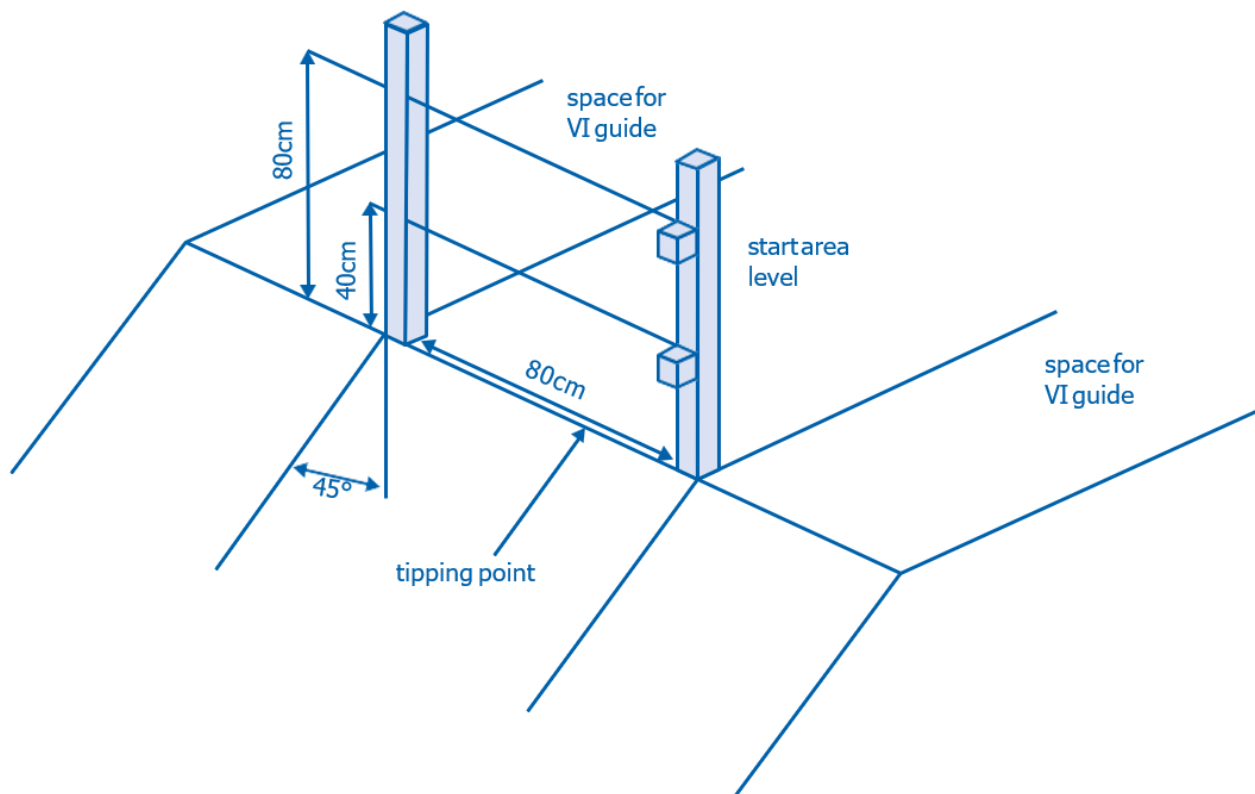

- The start area must be wide enough to accommodate the start referee, the starter and manual timers.
- In the B-classes (Vision Impaired athletes with guides) the guide cannot pass through the starting gate.
- The start area must include adequate space for the guide, a minimum of one (1) meter on each side, always in relation to the first gate of the course. The space should be at the same level as the competitor.
- The start ramp shall be prepared in such a way that the guide can stand relaxed on the starting line and can quickly reach full speed after leaving the start.

## Start-building tools



Basic start-building tools include:

- Tape measure
- Battery-powered drill to break the compacted snow and ice at the start post locations and to honeycomb the start area
- Ice auger to drill the post holes to the proper depth
- Small hand level to plumb the posts
- Square nosed steel shovel with a straight handle for filling and compacting snow around the posts
- Long handled aluminium rake
- Several containers of water to ice in the posts and pads



The start gate consists of two square posts, 150cm long and 9cm square. The top of the posts must be flat. The posts must be placed at the front edge of the start ramp. The area up to the front face of the posts must be level. The slope starts at the front face (course side) of the posts.





### **Start post setup**

- The start posts must be set 80cm apart
- They must be square to the fall line
- The posts must be perfectly level and plumb
- The locations of the start posts should be in the middle of the start area

### **Start post installation**

- Begin by drilling the post locations with a drill to break up the hard packed snow
- The holes should be augured to the proper depth with an ice auger
- Once the proper depth and separation are achieved, then backfill the holes with snow and tamp with the shovel handle
- Add water as the hole is filled to help freeze the posts in place



Two timing wands are mounted on one of the start posts.

- One wand at 40cm above the snow surface for standing athletes and one wand at 80cm above the snow surface for sit-skiers.

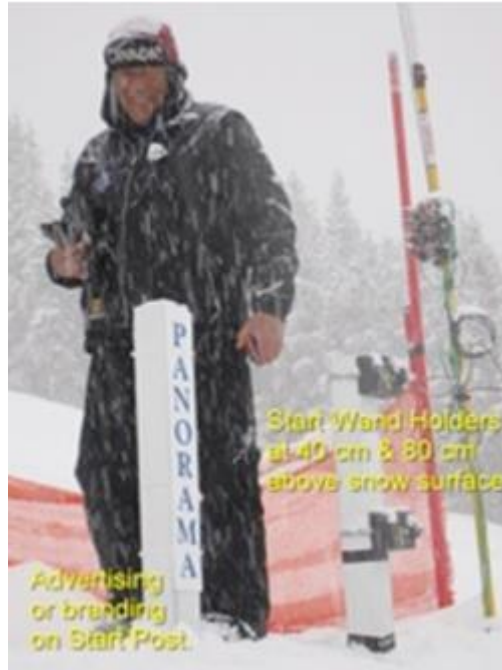

The timing wand is 2.5cm below the top of the wand holder.

It is suggested that the top of the start posts should be set a minimum of 90cm above the surface of the snow.

It would be helpful if the posts were etched with a saw at 10cm, 50cm and 90cm from the top of the posts. This would assist when installing the posts and timing wands.

Start wand holders are positioned so the start wand is at a height of 40cm or 80cm.

If advertising or branding is installed on the start posts, it should not interfere with the progress of the athlete.



Start Pads (40cm X 60cm)

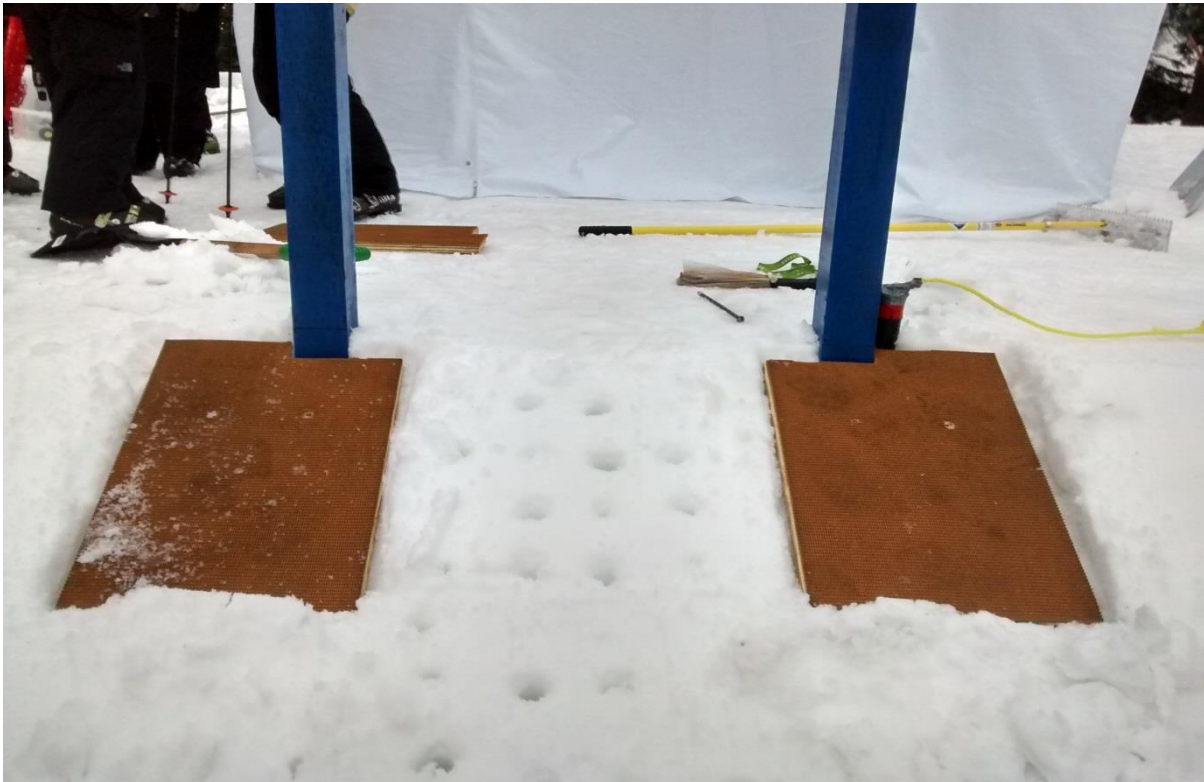

Sit Skier Starting Pads (40cm X 60cm)

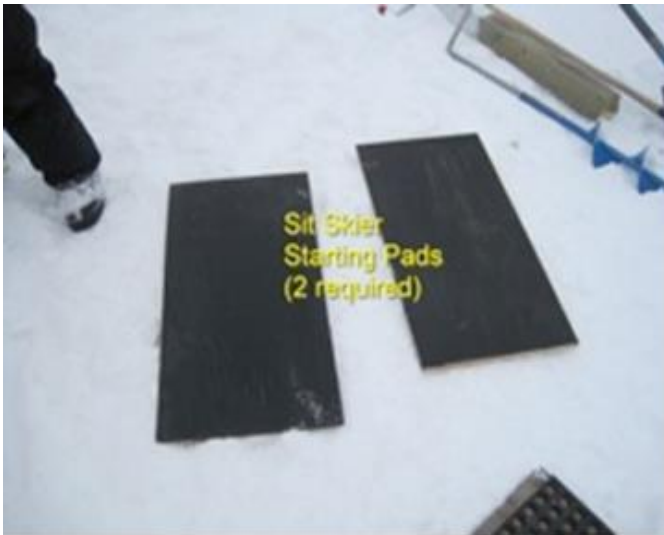

## A Level firm start area

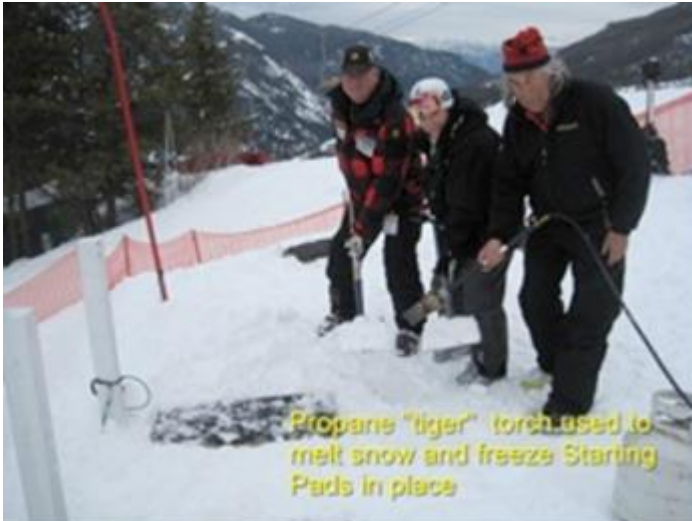

- The area behind the start posts must be perfectly level and firm
- A skier must be able to stand in the area and not slide forwards
- As noted earlier, the 'tipping point' is at the forward edge of the start posts
- In addition, the surface must be firm
- Drilling the snow in a honeycomb pattern and then filling the holes with water will achieve this
- Fresh snow is then spread over the wetted area and carefully tamped with the flat face of the aluminium rake
- The entire area between the sit skier starting pads up to the start posts and 30cm behind the sit skier starting pads should be drilled
- The spacing of the honeycomb pattern is dependent on the snow conditions and temperature
- The start ramp area may also be drilled in a honeycomb pattern to prevent this area from breaking down during the race event
- In addition the entire surface of the start area may be glazed with the aid of the propane "Tiger" torch



*World Para Alpine Skiing wishes to thank Dennis Waddingham and Rudy Zellman of Canada for their contribution to the material presented in this manual, as well as Davide Cerato for his image contributions.*